

GILES G-202140

Assembly Manual



Specifications:

Wing Span: 70"
Wing Area: 1022 in²
Length: 70"
Weight: 10-10.5 lbs
Engine: 1.08-1.6 2 Cycle
1.2-1.8 4 Cycle
Radio: 7 Channel w/6 Servos

Thunder Tiger G202-140 ARF Airplane (TTR4550)

Distributed in North America by Ace Hobby Distributors, Inc. • 116 W 19th ST, Higginsville, MO 64037
Phone: 660-584-7121 • www.acehobby.com • email: service@acehobby.com

Warranty

This kit is guaranteed to be free from defects in material and workmanship at the date of purchase. It does not cover any damage caused by use or modification. The warranty does not extend beyond the product itself and is limited only to the original cost of the kit. By the act of building this user-assembled kit, the user accepts all resulting liability for damage caused by the final product. If the buyer is not prepared to accept this liability, it can be returned new and unused to the place of purchase for a refund.

Notice: Adult Supervision Required

This is not a toy. Assembly and flying of this product requires adult supervision.

Read through this book completely and become familiar with the assembly and flight of this airplane. Inspect all parts for completeness and damage. If you encounter any problems, call 660-584-6724 for help.



INTRODUCTION



Congratulations on the purchase of one of our finest ARFs to date. This scale replica of the famous Giles G-202 is as faithful in its appearance as it is in its flight characteristics. Beautifully reproduced using balsa and ply construction. Covered in durable and easily repairable UltraCote®, this plane is highly visible in the air and strikingly recognizable on the ground.

PRE-ASSEMBLY NOTES

Before beginning the assembly read the instructions thoroughly to give an understanding of the sequence of steps and a general awareness of the recommended assembly procedures.

By following these instructions carefully and referring to the corresponding pictures, the assembly of your model will be both enjoyable and rewarding. The result will be a well built, easy to assemble ARF model, which you will be proud to display.

This G202-140 is designed for intermediate to advanced pilots, and this manual assumes a basic knowledge of R/C model construction.

Before you begin, check the entire contents of your kit against the parts list and photos to make sure that no parts are missing or damaged. This will also help you to become familiar with each component of your plane. If you find that any of the parts are either missing or damaged, please contact Ace Hobby Distributors, Inc., Customer Service (660-584-6704) immediately for replacements.

Please read the entire manual before beginning construction.

Neither your dealer nor Ace Hobby Distributors, Inc., can accept kits for return if construction has begun.

Trial fit each part before gluing it in place. Make sure you are using the correct part and that it fits well before assembling. No amount of glue can make up for a poor-fitting part.

TABLE OF CONTENTS

Introduction	2
Items Needed Check List	3
Parts Sketches	4-5
Wing Assembly	6-9
Stabilizer Assembly	9-11
Elevator Servos	11-13
Tailwheel	13
Landing Gear	13-14
Engine	14-15
Fuel Tank	15-16
Cowl	16-17
Switch & Receiver	17
Wing Attachment	17
Pilot	17
Canopy	18
Prop & Spinner	18
Control Throws	18
CG, Flight Tips	19

Adhesives:

Instant setting cyanoacrylate adhesive (thin CA)
 Slower setting cyanoacrylate adhesive (medium CA)
 5 Minute Epoxy (fast)
 20-30 Minute Epoxy (slow)
 R/C 560 Canopy Glue
 Zap-A-Dap-A-Goo II™

Tools:

Model knife, T-Pins, 1/2" vinyl tape
 Small screwdrivers, medium screwdrivers
 Lexan Scissors
 Steel straight edge
 Long nose pliers and diagonal cutting pliers
 Drill and drill bits
 Dubro 8-32 tap
 Sanding block
 Fine felt tip pen and soft lead pencil
 Straight building board

R/C System:

Seven channel radio with one standard servo and five dual BB high torque servos

Four 12" aileron extensions

One servo reverser Y-harness

Engine:

2 cycle: 1.08-1.60
 4 cycle: 1.20-1.80

Propeller (appropriate for engine type and preferred performance)



Radio - A 7-channel radio with 5 high performance servos and 1 standard servo is required.



Adhesives - You will need two types of adhesives for the G202-140 - Epoxy and Instant (cyanoacrylate) adhesives. We recommend that you purchase both 5-minute and 30-minute epoxy to cut down on assembly time, but you can get by with only 30-minute epoxy if time is not important. You will also need a small bottle of both "Thick" and "Thin" instant CA adhesive.



Tools - Model assembly can be much easier if the proper tools are used. Therefore, we have included in our checklist to the left, a complete listing of all the tools we used to assemble our prototype models. As you will notice, many household tools can be utilized during construction.



Engine - The Thunder Tiger PRO-120 is the ideal engine for this airplane. This quiet-running engine is easy to start, requires no special break-in periods, is very easy to maintain and will last for years.

<p>AS6146 Main Wing Set</p> <p>Main Wing(L/1 R/1)</p>	<p>Wing Joiner(4) Wing Bolt(2)</p> <p>Wing Bolt Plate(1) Belly Front Former(1)</p> <p>Fiber Cloth(1) Dowel(2)</p>	<p>PE0009 Hardware Set (Sold in Pair)</p> <p>Pushrod Connector(1)</p> <p>Allen Wrench(1)</p> <p>3mm x 3mm Set Screw(1)</p> <p>2mm Hex Nut(1)</p>
<p>AS6145 Fuselage</p> <p>Fuselage(1)</p> <p>2.3mm x 12mm Wood Screw(4)</p>	<p>AS6151 FRP Belly Pan</p> <p>FRP Belly Pan(1)</p>	
<p>AS6147 Horizontal Tail</p> <p>stab./Elevator(L/1,R/1)</p> <p>Carbon Tube(2)</p> <p>2.3mm x 12mm Wood Screw(4)</p>	<p>AS6148 Vertical Tail</p> <p>Vertical Fin/Rudder(1)</p>	<p>AS6152 Canopy</p> <p>Canopy (1)</p>
<p>AS6149 Main Landing Gear</p> <p>Main Landing Gear(1)</p> <p>Wheel Pant(L/1, R/1)</p> <p>4mm x 40mm Socket Screw(2)</p> <p>4mm Nut(4) 4mm Locknut(2) 4mm Washer(2)</p>	<p>AS6150 FRP Cowling</p> <p>FRP Cowling(1) Mounting Ring(1) Mounting Block(4)</p> <p>2.3 x 12mm Wood Screw(4)</p>	
<p>No.3278W Spinner</p> <p>Spinner(1)</p> <p>Back Plate(1)</p> <p>3mm x 12mm Self-Tapping Screw(4)</p>	<p>No.3013 Swivel Ball Link Control Horn Set (Sold in Pair)</p> <p>Control Horn(6)</p> <p>Back Plate(4)</p> <p>2mm x 22mm Screw(15)</p> <p>2mm Hex Nut(15)</p>	<p>No.3272 Fuel Tank Set</p> <p>Nipple(1) Cap(1) Silicone Tube(1)</p> <p>Clunk (1) Fuel Stopper(1) 90-degree Nipple(1)</p> <p>720 c.c. Tank(1)</p>

No.3014 Pull-Pull System

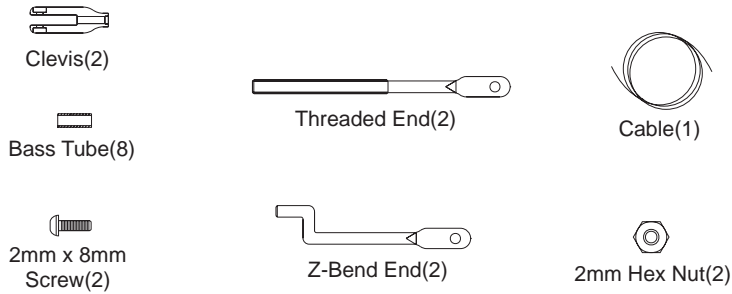

No.3016 2.3mm Pushrod Set(Sold in Pair)

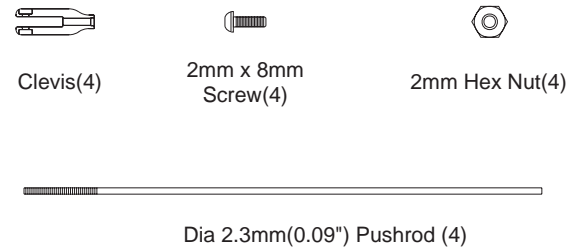

AS6153 Piano Wire

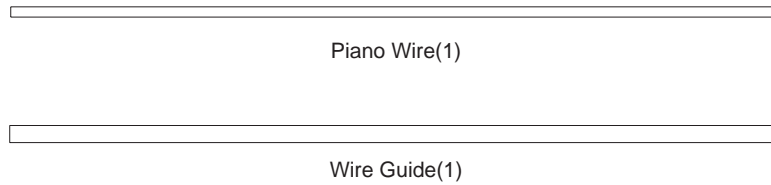

No.3012 Anti Vibration Engine Mount

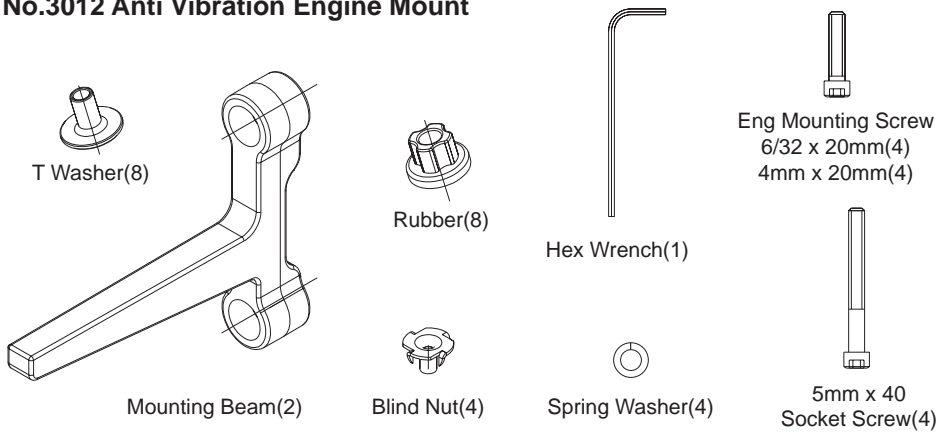

AS6154 Decal



No.3015 Scale Tail Gear

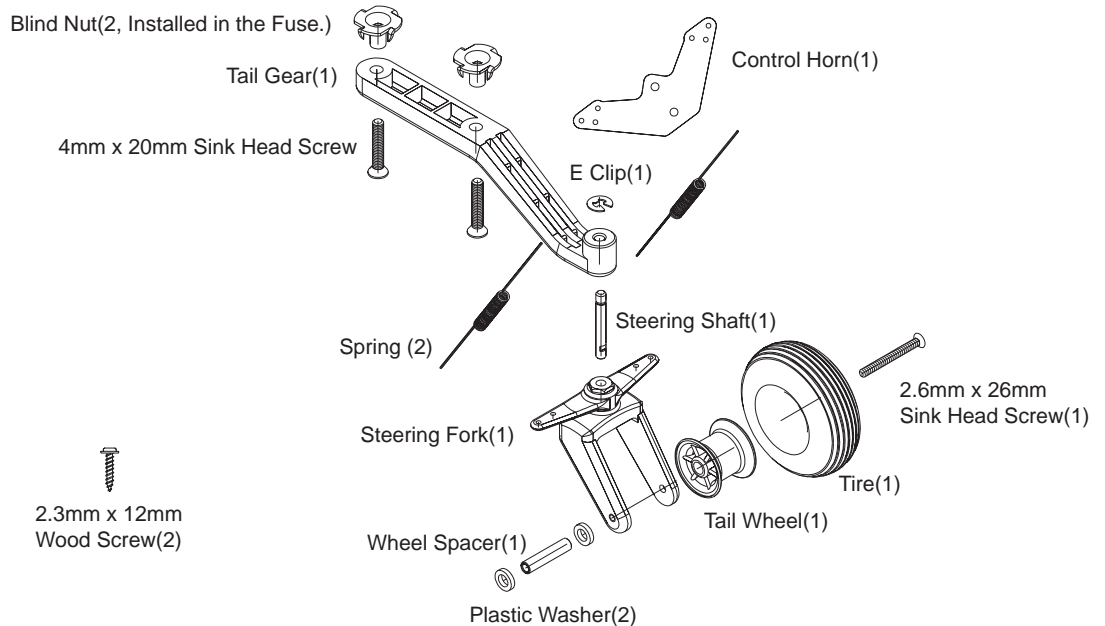

WING ASSEMBLY

I. Mount Servos



- With the wing panel upside down, locate the servo well and cut an X from corner to corner using an Xacto knife.



- Use a sealing iron to tack down the covering inside the servo well.



- With the wing rightside up, locate the servo wire exit hole and remove covering.



- Attach the 12" aileron extension lead to the servo.

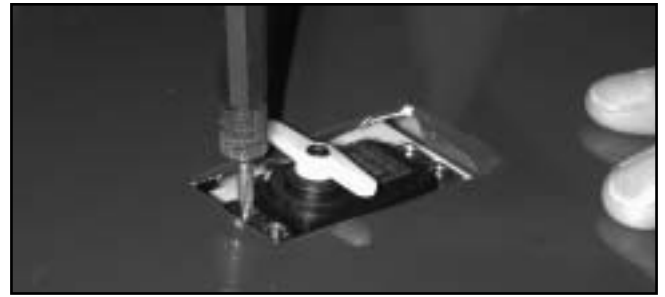

- Install the servo in the wing. Use a servo arm instead of the standard wheel.



- Use a piece of clear tape to temporarily hold the servo pigtail to the wing to prevent it from slipping back into the wing while you are working.

II. Install Ailerons

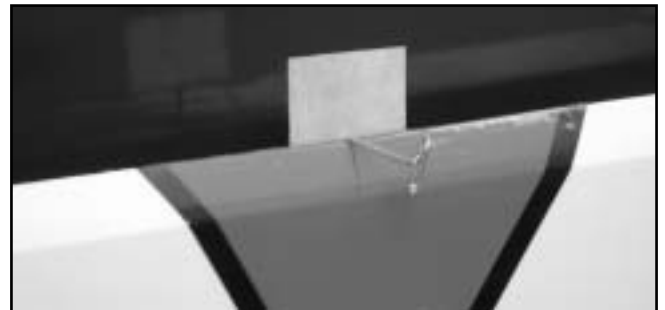

- Remove the aileron and insert T-pins into the centers of the hinges. Install aileron onto the wing, remove T-pins, and apply thin CA to the hinges (both sides).

III. Join Wing Panels



- Install control horns. Use a pen or marker to mark the positions for the aileron control horn.



- Drill out the holes as shown. Attach the control horn using the enclosed bolts and control horn back plate.



- Attach the Z-bend end of the control rod to the servo horn, then attach the clevis to the threaded end and bolt it to the control horn. It may be necessary to enlarge the hole in the control arm to allow the Z-bend to fit.

Note: The pushrod is 2.3mm(0.09"), you have to locate the right clevis which has bigger hole for pushrod to thread in.

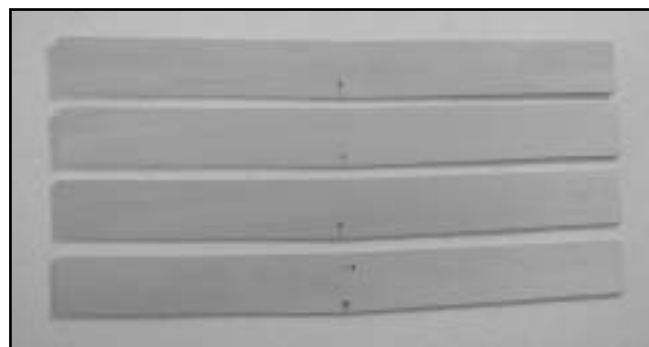

- Locate the four dihedral braces and stack them, then mark an arrow indicating the 'up' edge. Trial fit the braces in each wing panel. If needed, sand the edges lightly so that the brace fits in each wing smoothly.

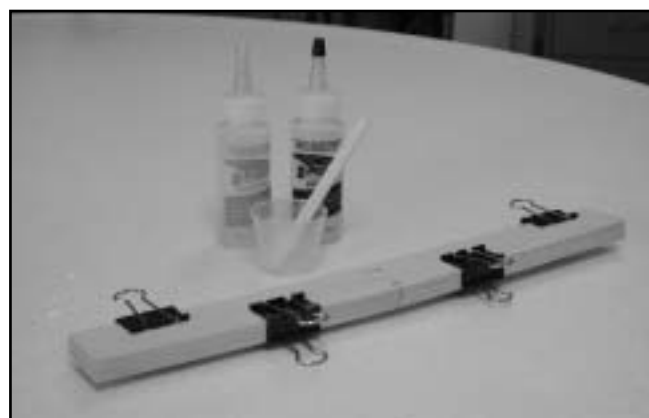

- Mix some 5 minute epoxy and laminate the four dihedral braces together and clamp for 30 minutes.



- Mix up some more 5 minute epoxy and glue the dihedral brace into one of the wings and let it dry for 30 minutes.



- Mix up an ample amount of 30 minute epoxy and apply to the inner ribs on each wing panel and dihedral brace and make sure you have plenty inside the wing joiner slot. Slide the wings together, tape around the joint, and wipe off any excess epoxy. Set aside for 1 hour.

WING ASSEMBLY



□ Using 5 minute epoxy, attach the front belly plate and wing alignment dowels and let sit for 30 minutes.

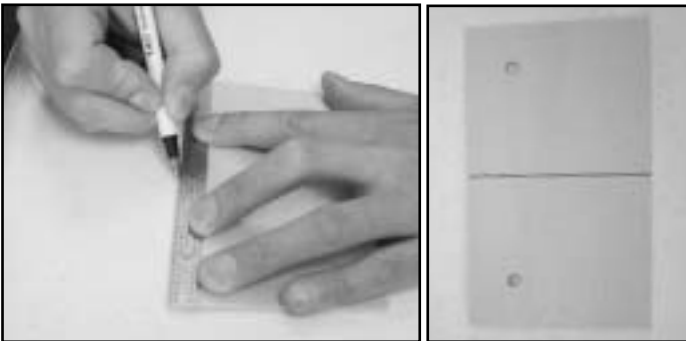

□ Measure the top and bottom to find center of the wing hold-down plate and draw a straight line between the two marks. This line will be used to center the plate on the trailing edge of the wing panel.



□ Place the plate on the wing panel and mark around the three sides with a pen or marker. Remove the plate and then remove the covering material inside the lines. Be careful not to push through the balsa; remove only the covering.



□ Apply a liberal amount of medium CA to the exposed wing panel and place the holddown plate on it, holding it until the CA sets.

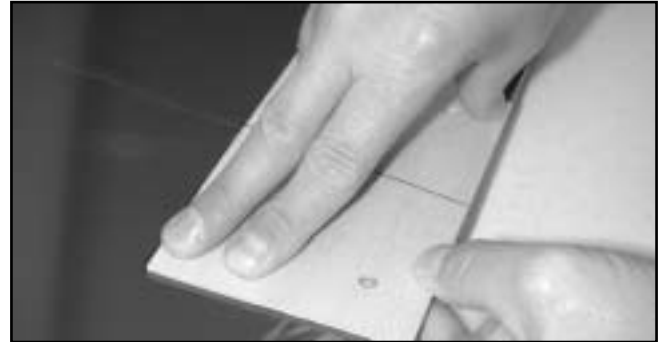

□ Turn the fuselage upside down and trial fit the wing assembly into place to insure good fit.

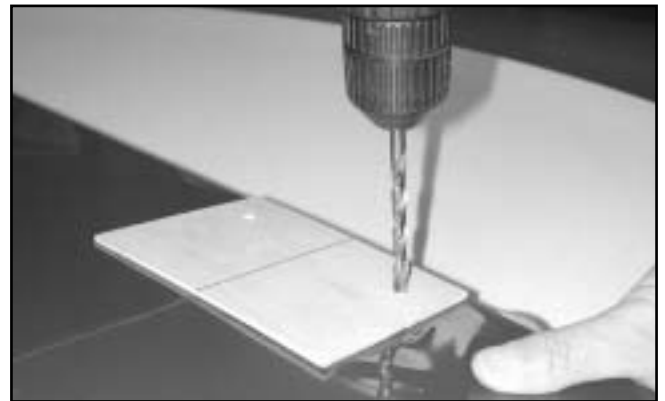

□ Remove the wing and with a 1/4" drill bit drill through the existing holes in the wing hold down plate and through the trailing edge of the wing.

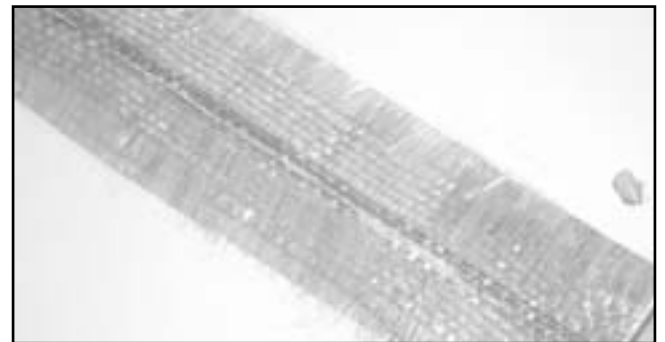

□ Epoxy the wing joint with fiber cloth both on top and bottom.



☐ Install the blind nuts into the fuselage and bolt on the wings.

☐ Install the bolts into the wings.



☐ Run a bead of Zap-A-Dap-A-Goo II™ along the bottom surfaces of the fairing balsa and along the front inside of the fiberglass. Attach to the wing assembly and let sit overnight.

II. Install the Stab, Fin & Rudder

The G202-140 stabilizer can be installed two different ways: removable stab and permanently mounted stab. In our construction, we have opted for the permanent one.



☐ Locate the two holes on each side of the rear of the fuselage and remove the covering film from them.

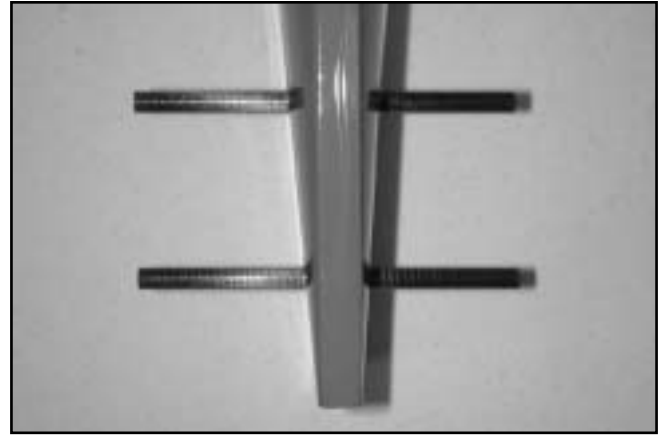

☐ Insert the two carbon fiber spars into the fuselage and center them. Next slide one stab onto the spars on one side.

Removable Stab:

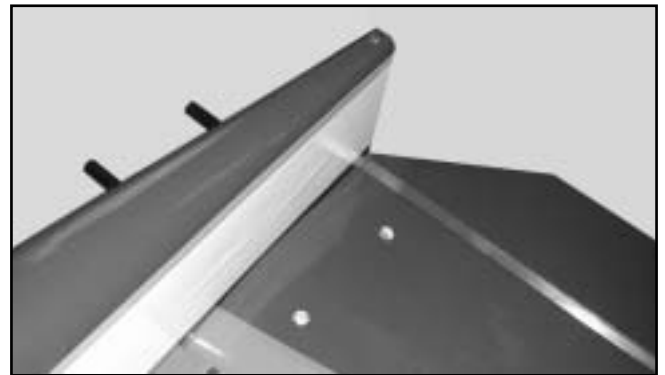

☐ Locate and remove the covering material from the two holes on the bottom of the stabilizers.

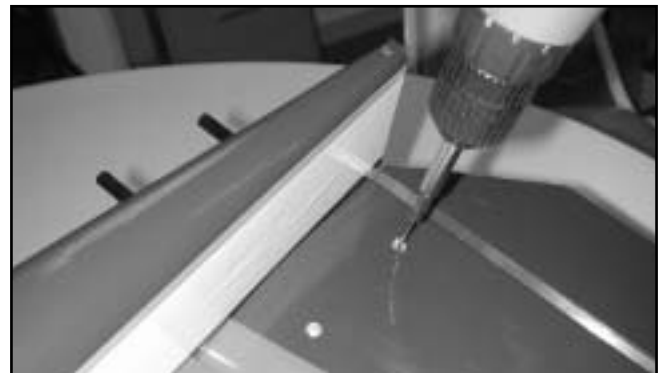

☐ With a 1/16" drill bit drill one hole through the tubes and spars in the holes on the bottom of the stab. **BE CAREFUL NOT TO DRILL ALL THE WAY THROUGH THE STAB.**

Note: Predrill the 1/16" holes in the stabs first; when the stabs are in place you will know to drill only through the first layer of the spars.

STAB, FIN & RUDDER

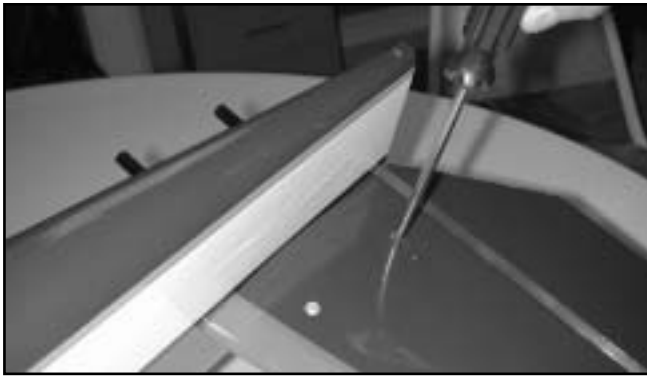

- With the stab and spars in place use a 3x10mm self tapping screw to attach the stab to the spars. Repeat "Removable Stab" section for other side.

Permanent Stab:

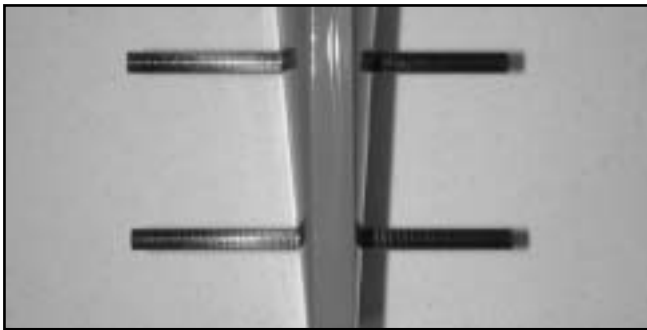

- Insert the two carbon fiber spars into the fuselage and center them. Next slide one stab onto the spars on one side.



- Place the stab on the spars and against the fuselage. Mark around the stab with a pen or marker and remove the covering material inside the lines from the fuselage.

- Mix up some 5 minute epoxy and glue the spars into the fuselage. Let sit 10 minutes.

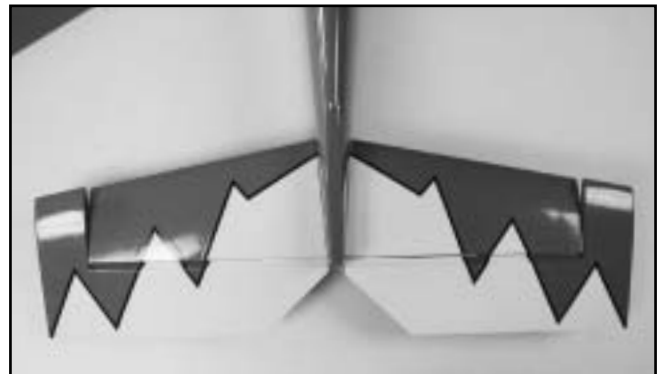

- Mix up some 5 minute epoxy and glue the stabs to the fuselage and let sit 15 minutes.

- Remove the elevators and rudder, T-pin the hinges.



- Remove the covering from the 1/2" wide flat strip at the top rear end of the fuselage.

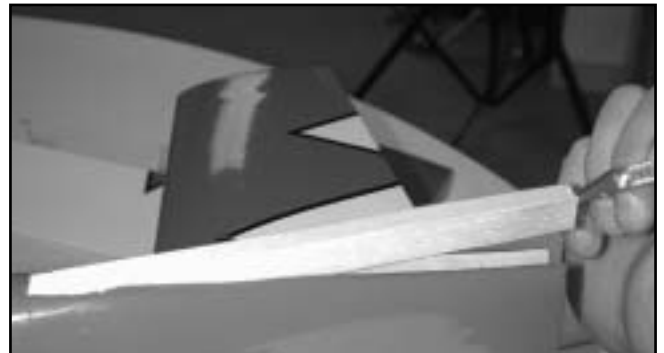

- Carefully cut 1/2" deep on either side of the exposed area and remove the block inside (this block should be loose from the factory but is only there for strength during sanding and covering.).

ELEVATOR SERVO INSTALLATION

III. Elevator Servo Linkage and Control Horns

- Locate the servo well at the rear of the fuselage and cut an X through the covering material over it with an Xacto knife. Seal the flaps of covering material down with a sealing iron.

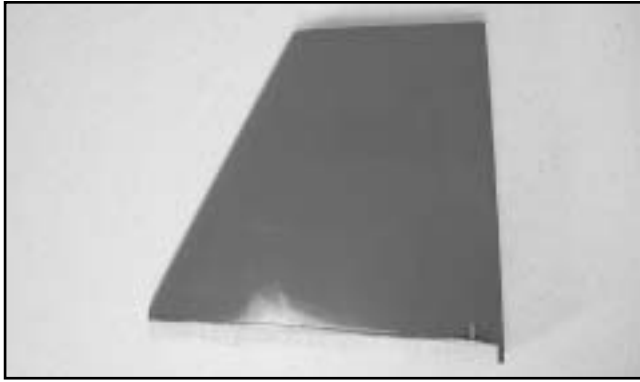

- Insert the fin into the fuselage and mark the fin against the edge of the fuselage; cut and remove covering material at the bottom of the fin.

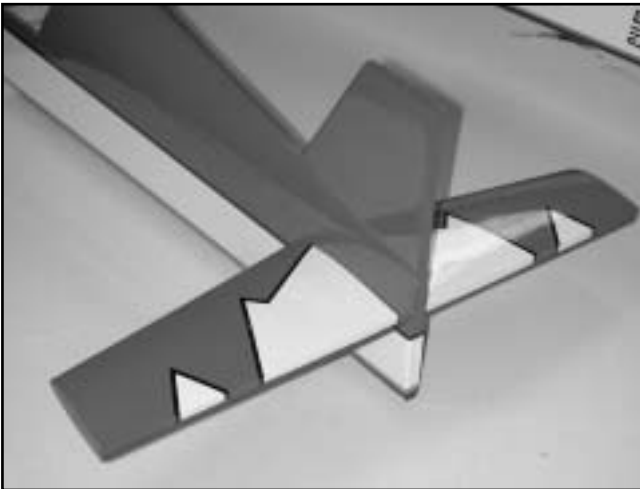

- Using 5 minute epoxy, attach the fin to the fuselage.

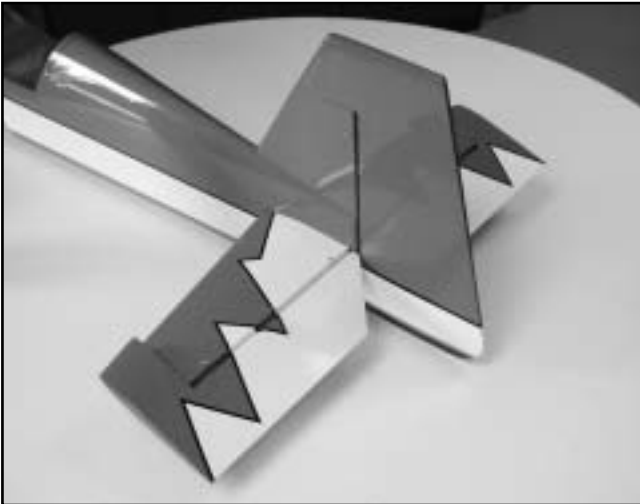

- Hinge the elevators and rudder using thin CA.



- Attach the 12" extension lead to the servo and install it.

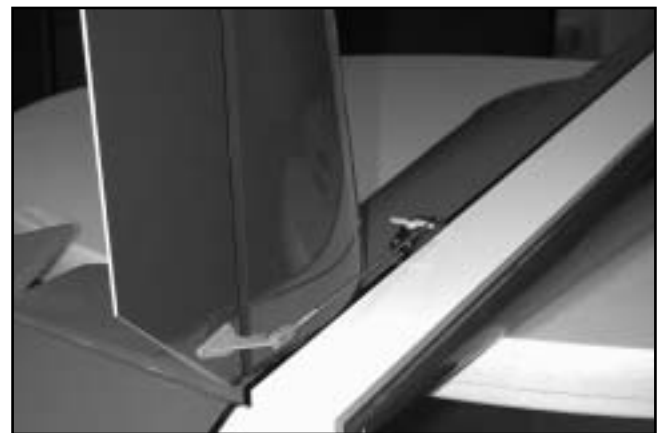

- Place the control horn on the bottom side of the elevator and mark screw holes with a pen or marker. Drill the holes all the way through the elevator. Attach the control horn using the 2x22mm bolts and nuts provided. Thread the clevis onto the pushrod and use the 2x6mm bolt and nut to attach the clevis to the control horn.

ELEVATOR SERVO INSTALLATION

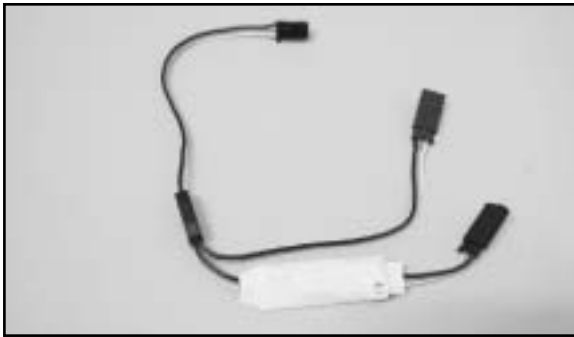

Note: The G202 using dual elevator servos requires the use of a servo reverser Y-harness, which reverses the signal to 1 servo and not two, allowing them to work together. There are several servo reverser Y-harnesses on the market (Jomar, Maxx Products, etc). We are using the Jomar SR2YJR.

- Repeat steps from “III. Elevator Servo Linkage and Control Horns” for other side.
- Connect the 12" extension lead to the second elevator servo, and attach the servo reverser Y-harness to both elevator servo pigtails. Tape all servo extension connectors to prevent them from coming loose during flight.

IV. Rudder Servo and Linkage Installation



- Install the rudder servo as pictured.



- Place the aluminum rudder control horn plate onto the exposed space on the bottom of the rudder and mark the holes with a pen or marker. Using a 1/16" bit, predrill the holes 1/2" deep. You can keep from drilling too deep by running a piece of masking tape around your drill bit at the desired depth.

- Install the aluminum rudder control horn plate onto the bottom of the rudder using the 2.3mm self-tapping screws provided.



- Place a control horn on right hand side of the rudder and mark the holes, remove the control horn and drill the holes through the rudder. Attach the control horn using 2x22mm bolts. On the other side of the rudder, use a second control horn in place of a backing plate. Thread the nuts and tighten down bolts.



- Use a pen or marker to mark the exit hole for the pull-pull cable below the stabilizer, and use an Xacto to remove balsa and covering.

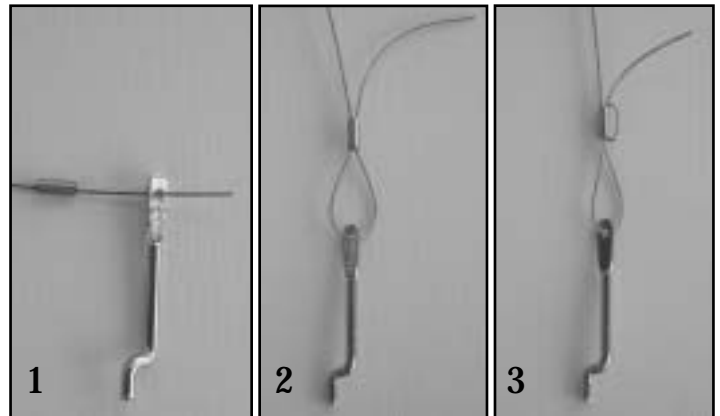

- Locate the Z-bend end for the pull-pull rudder. There will be two Z-bend ends and two straight threaded ends. The threaded ends go to the control horns on the rudder and the Z-bends go to the servo in the airplane. You will also have two pieces of pull-pull cable and four small brass tubes which you will use to crimp on the cable after it is knotted.

- Slide one of the brass tubes onto one end of the cable, then slide the Z-bend end onto the same end as Fig. 1. Route the cable and slide the cable end to the brass tube as Fig. 2. Slide the Cable end to brass tube again as Fig.3. Adjust the length of cable shorter than 1/2" at the Z-bend end and brass tube. Now crimp the tube tight with a pair of pliers.

- Drop the Z-bend end through the exit hole in the tail and through the fuselage. Next attach the Z-bend end to the control horn on the rudder servo. Then use a piece of masking tape to hold the cable to the fuselage to keep it from sliding all the way through.

TAILWHEEL & LANDING GEAR



- ❑ Attach the clevis with small pushrod hole to the straight end and to the control horn using the 2x6mm bolt and nut provided.
- ❑ Use a piece of masking tape to hold the rudder straight. Next tie the remaining cable to the straight end/clevis assembly, knot and crimp as before. Trim any excess cable.
- ❑ Repeat for other side.
- ❑ Tensioning the cables: to tension the cables, detach one of the clevises and thread it further onto the straight end just a couple turns at a time, reattach the clevis, then do the same for the opposite side. Repeat until cables are firm. Cables do not need to be overly tight.

V. Tailwheel Assembly

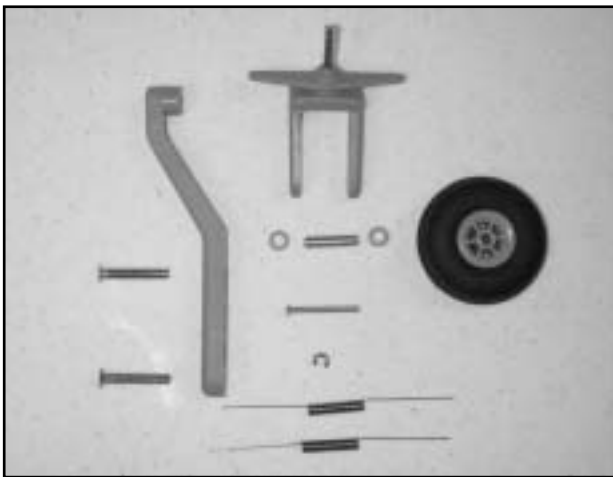

- ❑ Locate the pieces for the tailwheel assembly.
- ❑ Insert the brass bushing into the tailwheel and place a plastic washer on each side. Place these between the tailwheel yoke. Run the 2x22 counter sunk screw through the bushing and into the other side of the yoke. Pay special attention to do this from the side with the recessed area for the countersunk screw.



- ❑ Install this assembly onto the tailwheel bracket with the provided E-clip.

- ❑ Locate the two tailwheel holes in the bottom of the fuselage and remove the covering. Attach the completed tailwheel assembly using the two countersunk screws provided.



- ❑ Using a pair of needlenose pliers, curl the ends of the springs around the outermost hole on the aluminum plate and the holes in the tailwheel yoke. Make sure that the tailwheel stays in line with the rudder.

VI. Wheelpants and Main Landing Gear



- ❑ Cut the wheel pants as shown.

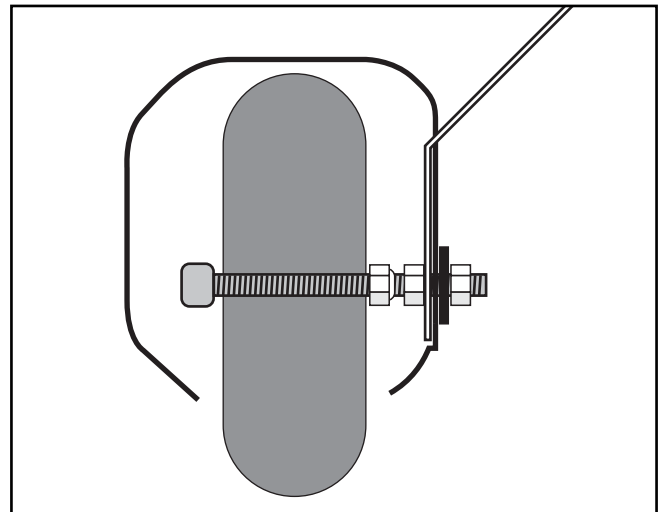

- ❑ Run the 4 x 40mm socket head bolts through the large wheels followed by a 4mm locknut. Tighten just enough so that the wheel can turn freely. Then thread another 4mm nut and push it all through the landing gear and wheel pant. Adjust the wheel is centered in the wheel pant then tighten down with a washer and another 4mm nut. Repeat for other side.

LANDING GEAR & ENGINE MOUNT

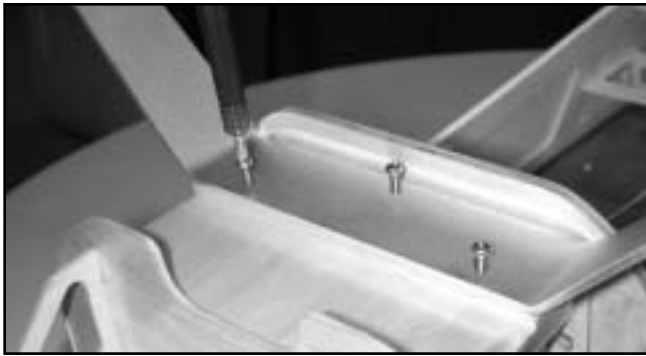

□ Locate the three 4x16mm screws to attach the main landing gear to the fuselage. It would be a good idea to use a bit of Loctite™ on these bolts to make sure they do not vibrate loose in flight.

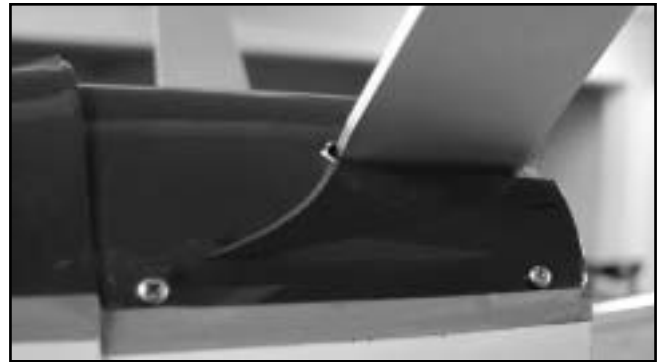

□ Trial fit the landing gear cover onto the bottom of the fuselage and landing gear. When satisfied with fit, secure with four 2.3 x 12mm wood screw.

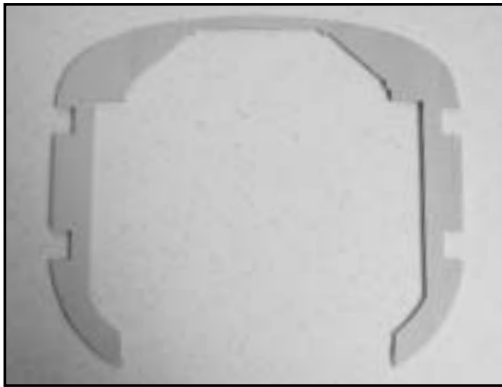

□ Cut the middle 5 7/16" from the bottom of the cowl mounting ring to accommodate for the exhaust scoop, then attach the cowl mounting ring to the fuselage using medium CA.

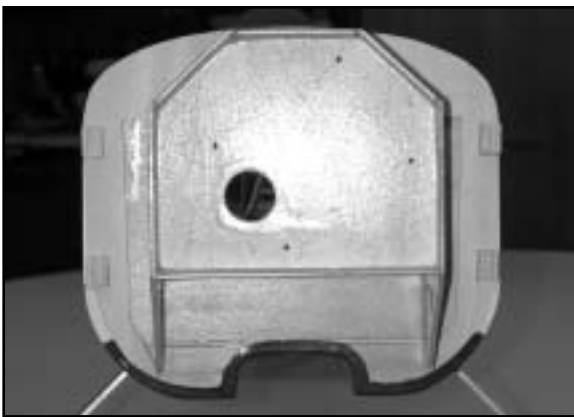

□ Using 5 minute epoxy glue the cowl mounting blocks into place. Be sure that the grain goes with the length of the aircraft or they will split.

VII. Install the Motor Mount



□ Locate the motor mount hardware: two motor mounts, four socket head bolts, and four blind nuts.

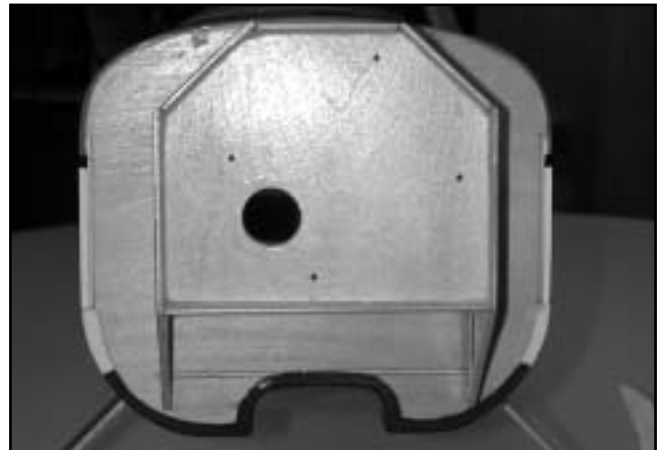

□ Using a 1/4" drill bit, drill four holes in the firewall using the dimples as a guide.

ENGINE MOUNT & FUEL TANK



- Attach the engine mounts to the firewall using the socket head bolts and blind nuts.



- Set the engine on the engine mounts and measure from the firewall to the front of the thrust washer 6 1/4". Now use a marker to mark the engine mounting holes on the engine mounts.



- Use a marker to mark the engine mounts as right and left. Now remove the engine mounts. Place into a vise and drill and tap the holes using an 6/32 or M4 x 0.7 Tap.

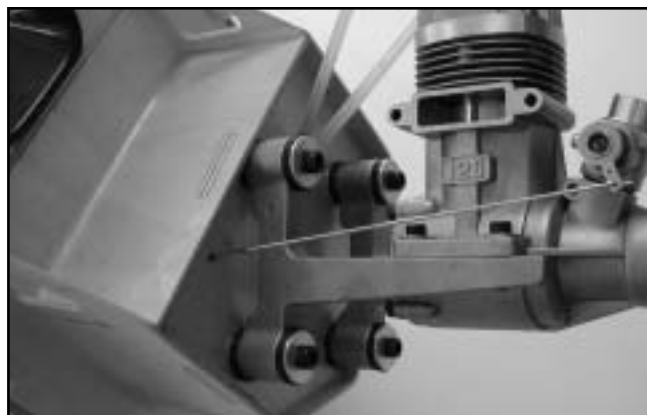

- Mark and drill the hole for the throttle pushrod tube. Install the pushrod tube and use a couple of drops of medium CA to hold in place in the firewall. Now install the throttle pushrod, attaching Z-bend end to the throttle arm. You may now permanently install the engine by using the enclosed 6/32 x 20mm or 4 x 20mm socket head screws. We advise that you use a couple of drops of blue Loctite™ on each motor mount bolt.

VIII. Fuel Tank



- Assemble the fuel tank.



- Install the fuel tank, then install the throttle servo tray using medium CA. This tray holds the fuel tank into place, so place it as far

COWL ATTACHMENT



forward as possible.

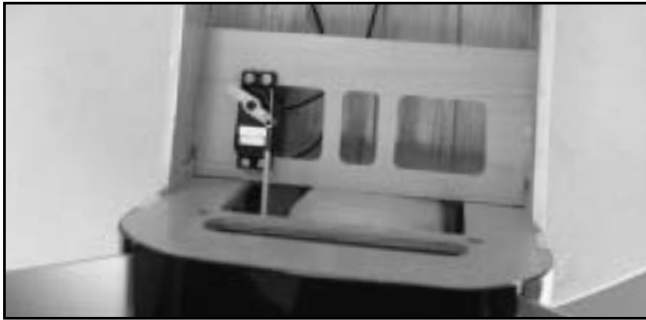

□ Install throttle servo & attach the EZ connector to the throttle servo arm. Please adjust with the servo in the neutral position and the carburetor at half throttle. This will give you an excellent starting point for radio setup.

IX. Cowl Attachment

□ With the engine of your choice installed, it will be necessary to cut holes in the cowl to accommodate cylinder heads, needle valves, glow plug access, etc. In order to do this, create a template in the following fashion: With engine in place, tape strips of standard paper to the fuselage over the area that will need to be removed from the cowl. Make sure the pieces of paper are long enough to cover the cowl.

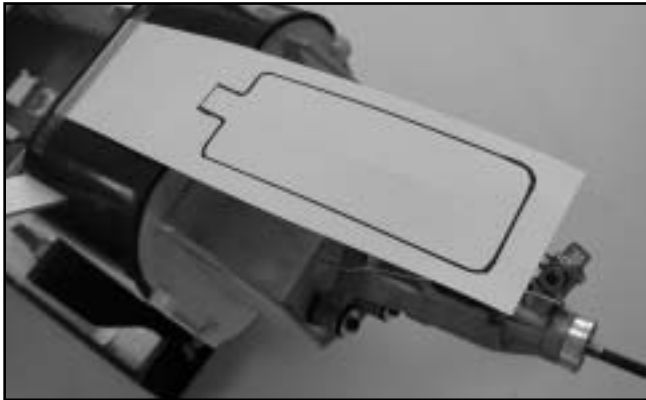

□ Tape the paper into place against the fuselage and carefully draw around the necessary areas. Now using an Xacto knife, cut out the drawn area.



□ Now remove the engine, put the cowl into place and tape the

template against the cowl. Use a marker to draw inside the template on the cowl.



□ As with any cowed engine, you will need to cut adequate cooling holes, so we have drawn where we will cut them on the front.



□ Before permanently installing the cowl, we have opted to install a Thunder Tiger #1115 Precision Fueler Valve.



4. Put the cowl in place. Mark the holes for the cowl attachment screws and drill using a 1/16" drill bit.

SWITCH AND RECEIVER

X. Wing Attachment



- ❑ Attach the cowl using the four 2.3x12mm self-tapping screws.
- ❑ Trim the cowl using the included black and purple trim tape.

Note: Since the needle valve was not long enough to extend outside the cowl, we had to install an extension. Depending on the engine you use this may be necessary. We made ours out of the excess wire from the throttle pushrod.



- ❑ With the fuselage upside down, connect the aileron servos to the receiver and bolt the wing on.
- ❑ Trim the belly pan with the enclosed purple trim tape.

X. Switch and Receiver Installation



- ❑ Set the switch plate against the left side of the fuselage and scribe a line inside the switch plate with an Xacto knife. Remove the switch plate and cut through the covering and balsa. We have placed our switch against the black trim stripe to minimize its appearance.

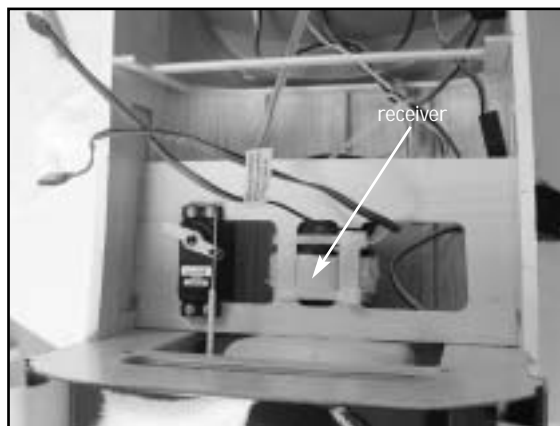

- ❑ Wrap the receiver and battery pack in foam padding and place where necessary for proper balance. We secured our receiver to the throttle servo tray and fitted our battery pack above the fuel tank.

XI. Pilot



- ❑ If you choose to use the enclosed pilot, cut in half and trim off the flashing from around the edges of his head. Glue both halves together and mount onto torso and paint with modeling enamel. We have chosen to use a 1/4 scale Cap'n Ed (ACE60K64).

CANOPY, PROP, CONTROL THROWS



XII. Canopy



- Put instrument panel stickers in place.



- Using a pair of Lexan scissors, trim the canopy along the faint mold line.



- Trial fit the canopy on the cockpit. When satisfied with fit, glue it in place with Formula 560 Canopy Glue, trim with striping tape and set aside for 24 hours.

XIII. Prop and Spinner

- Install the prop. We are using an APC 15x8 to go with TT PRO-120 engine.



- Attach the spinner. Depending on the prop you use, you may have to modify the spinner openings.

XIV. Control Throws

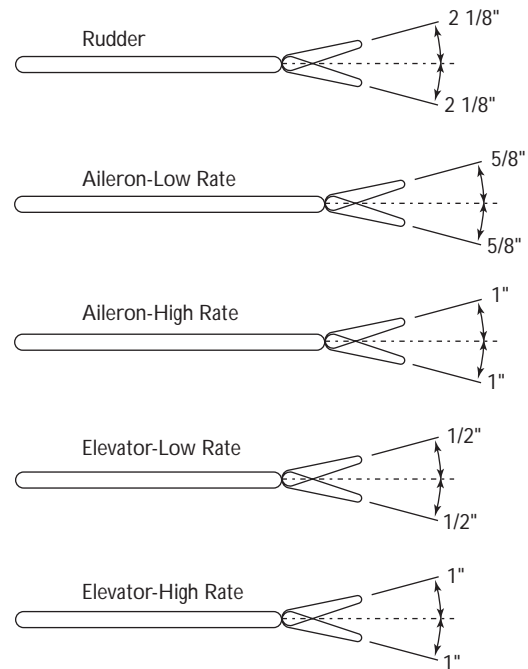

These control throws are merely a starting point for your radio setup and can be tailored to fit your flying style.

CLOUD DANCER 60 ARF

ACE4559



If you are looking for a perfect sport airplane, you can't go wrong with a Cloud Dancer 60. Designed by the late Fred Reese, the Cloud Dancer 60 incorporates a strong lightweight frame that provides instant acceleration and nimble responsiveness for very impressive and truly enjoyable performance.

Cloud Dancer sports a double-tapered wing, a unique diamond-shaped tail group, wide-stance landing gear and wheel pants, and sleek fuselage with bubble canopy. All of which results in a truly handsome airplane you can be proud of. Install the optional retractable landing gear, and watch the Cloud Dancer transform into the next level of awesome performance and good looks.

The Cloud Dancer 60 comes Almost-Ready-To-Fly, completely built from balsa/ply and skillfully covered with UltraCote™.

ACE4559 Cloud Dancer 60

Wing Span: 72"
 Wing Area: 840in²
 Length: 57"
 Weight: 6-7 lbs.
 Engine: .61 2 cycle
 .91 4 cycle
 Radio: 4 channel

- Skillfully built from balsa/ply and covered with UltraCote
- Sleek lines and tapered wing provides clean, smooth performance
- Set-up for fixed gear or optional retracts
- Available in 40 size or 60 size



Staudacher 60 ARF

ACE4563

ACE4563 Staudacher

Wing Span: 65"
 Wing Area: 780in²
 Length: 55.2"
 Weight: 8.5-9.5 lbs.
 Engine: .60 2 cycle
 .90-1.20 4 cycle
 Radio: 4 channel, 5 servos

Combine the scale appearance and striking color scheme of Diane Hakala's legendary Staudacher S-300 with the late Fred Reese's genius for light-weight yet sturdy construction, and you have an Almost-Ready-To-Fly airplane that will turn heads both on the ground and in the air. Now you can enjoy the experience of scale modeling without investing the hundreds of hours of time necessary to achieve satisfactory results.

Just because this is a scale airplane, don't think it is a "lead-sled". It is an extremely pleasurable airplane to fly with characteristics akin to a comfortable sport airplane rather than a fickle scale beauty. Solid tracking, instant acceleration, nimble aerobatics, and predictable landings make this airplane fly as good as it looks.

Completely built from balsa/ply and covered with UltraCote, this Almost-Ready-To-Fly airplane is ready to load up for the field in only a few short hours.

- Impressive scale appearance with sport performance
- Completely built from balsa/ply and covered with UltraCote™
- Quality epoxy/fiberglass cowl is flawlessly painted

