



INSTRUCTION MANUAL FOR THE 1:10 SCALE ELECTRIC 4WD TOURING CAR KIT

For kits:

#3010

#3011

#3012

#3013

#3014

#3015

#3030

#3035

Copyright 2000-2001 Associated Electrics, Inc.

TC3

EACH KIT INCLUDES

Pro-Line standard 12m Hex wheels & tires (except Factory Team kits).
 Aluminum motor mount with a built-in heatsink.
 Carbide ball Stealth differentials.
 Adjustable caster, camber, toe-in, anti-squat, kickup. Several tie-rod mounting positions.
 Foam bumper. TC3 decal sheet. Rear bumper.

RACER KIT

Shocks: VCS Macro shock.

Tires and Wheels: Pro-Line V-Rage tires and Axis wheels.

Front & Rear Axles: Composite MIP CVD's.

Turnbuckles: Associated steel turnbuckles

Choice of six Protoform bodies, with Protoform decals.

Also includes: Precision stainless-steel rubber-sealed ball bearings.

TEAM KIT

Shocks: Blue anodized aluminum-body VCS Macro shocks.

Tires and Wheels: Pro-Line V-Rage tires and Axis wheels.

Front & Rear Axles: Blue-anodized alloy MIP CVD's.

Turnbuckles: Factory Blue titanium turnbuckles.

Also includes: Precision stainless steel Teflon/rubber-sealed ball bearings.

FACTORY TEAM KIT

Shocks: Blue anodized aluminum threaded shock bodies, VCS Macro shocks.

Front & Rear Axles: Blue-anodized alloy MIP CVD's.

Turnbuckles: Factory Blue titanium turnbuckles.

Also includes: Precision Teflon-sealed ball bearings. Droop gauge. Anti-roll bar. Factory Team blue aluminum & graphite parts including: Counterfeit transponder mount. Radial clip-on heatsink. Graphite chassis. Unobtainium shock shafts. Blue aluminum screws.

TOOLS

KIT TOOLS SUPPLIED

- 1 Allen wrenches #6950 (.050", 1/16", 3/32", 5/64")
- 2 molded tools #6956
- 3 droop gauge #3987

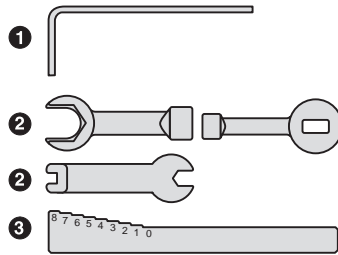

EXTRA STUFF NEEDED

- 1 Phillips screwdriver #2
- 2 needlenose pliers
- 3 soldering iron (40-50 watts) and a small amount of Rosin core solder. Pencil-type soldering iron is better than the gun type. **DANGER! Tip is HOT!**
- 4 Thread locking compound (#1596 Locking Adhesive or equivalent)
- 5 Super glue (cyanoacrylic glue, #1597 Tire Adhesive).
- 6 hobby knife **WARNING! This knife cuts plastic and fingers with equal ease, so be careful.**
- 7 precision ruler
- 8 electrician's tape
- 9 strapping tape

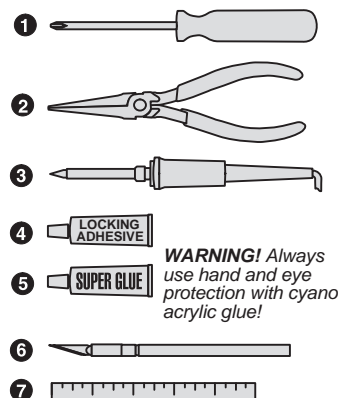

WARNING! Always use hand and eye protection with cyanoacrylic glue!

HELPFUL TOOLS (NOT REQUIRED)

- 1 Allen drivers (straight Allen wrenches with hex shaped handles) such as the following made by Associated:
 - #6957 .050" driver
 - #6958 1/16" driver
 - #6959 5/64" driver
 - #6960 3/32" driver
 - #6961 2.5mm driver
- 2 Vernier calipers
- 3 Hobby scissors
- 4 Nut drivers (screwdriver-handled hex socket tools)
 - 3/16" nut driver
 - 1/4" nut driver
 - 11/32" nut driver

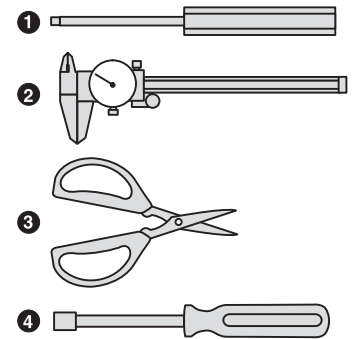

WARNING!

Do not use a power screwdriver to install screws into nylon, plastic, or composite materials. The fast rotation speed can heat up the screws being installed. They can then break the molded parts or strip the threads during installation.

ITEMS NEEDED TO COMPLETE YOUR CAR

- 1 R/C two channel surface frequency radio system.
- 2 *Battery pack (6 cell).
- 3 Battery charger (we recommend a peak detection charger).
- 4 *Electronic speed control.
- 5 *R/C electric motor.
- 6 *Pinion gear, size to be determined by type and wind of motor you will be using.
- 7 *1:10 scale Lexan body (Team & Factory Team Kits only).
- 8 *Touring car tires and wheels (Factory Team Kits only).

*Available from Team Associated. See your catalogs.

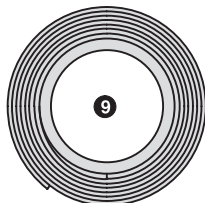
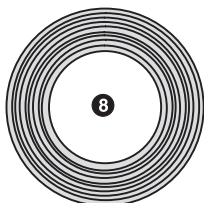

REACHING US

CUSTOMER SUPPORT
 (714) 850-9342
 Fax (714) 850-1744
<http://www.rc10.com/help>
<http://www.rc10.com/kits>



©2000 Associated Electrics, Inc.

ASSOCIATED ELECTRICS, INC.
 3585 Cadillac Ave.
 Costa Mesa, CA 92626-1401
 USA
<http://www.rc10.com> <http://www.teamassociated.com>

BEFORE BUILDING

OPEN THE BAGS IN ORDER

The assembly is arranged so that you will open and finish that bag before you go on to the next bag. **Sometimes you will have parts remaining at the end of a bag. These will become part of the next bag.** Some bags may have a large amount of small parts. To make it easier to find the parts, we recommend using a partitioned paper plate for spreading out the parts so they will be easier to find.

MANUAL FORMAT

The following explains the format of these instructions.

The beginning of each section indicates:

- 1 Which bag to open ("**BAG A**") and which steps you'll be using those parts for ("**FOR STEPS 1-3**").
- 2 Which parts you will use for those steps. Remove only the parts shown. "**1:1**" indicates an actual size drawing; place your part on top and compare it so it does not get confused with a similar part.
- 3 Which tools you should have handy for that section.

4 In some drawings, the word "**REAR**" with an arrow indicates which direction is the rear of the car to help keep you oriented.

5 The instructions in each step are ordered in the order you complete them, so read the words AND follow the pictures. The numbers in circles are also in the drawing to help you locate them faster.

6 When we refer to left and right sides of the car, we are referring to the driver's point of view inside the car.

7 Occasionally you will see an upside-down triangle next to a part. ▼ This indicates that more information is given about the part next to the matching triangle near the text.

SUPPLEMENTAL SHEETS

We are constantly developing new parts to improve our kits. These changes, if any, will be noted in supplementary sheets located in a parts bag or inside the kit box. Check the kit box before you start and each bag as it is opened. When a supplement is found, attach it to the appropriate section of the manual.

BAG A

REMOVE THESE PARTS FOR: Step 1

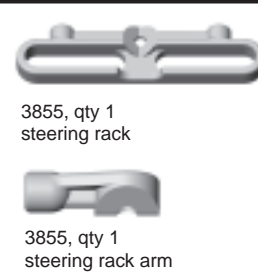
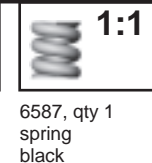
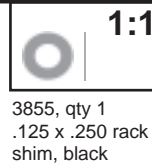
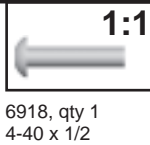
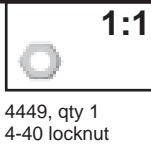

TOOLS USED

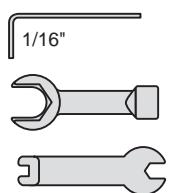

ASTERISK (*) DENOTES FACTORY TEAM PART NUMBER

step 1

STEERING RACK ASSEMBLY

- 1 Attach two #3858 short ball ends to the #3855 steering rack and one #3858 short ball end to the #3855 steering rack arm.
- 2 Slide the #6587 spring and the #3855 rack shim onto the #6918 screw. Slide the screw assembly through the bottom of the steering rack.
- 3 Attach the #3855 rack arm to the rack with a #4449 locknut.
- 4 Tighten down the spring until the screw is flush with the top of the nut.

Match this number to the text to find your way faster

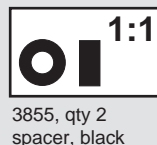
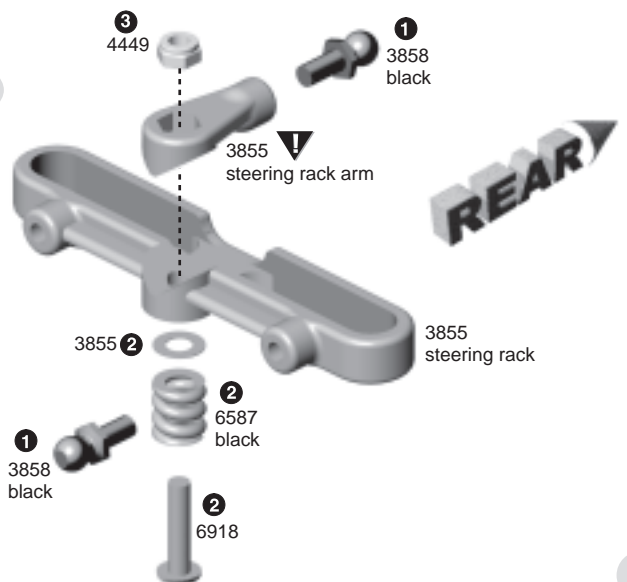

See page 21 for Ackerman setup options using the spacer supplied in bag A.

▼ Make sure the rack arm is facing the rear when assembled on the rack: The ball end on the rack arm and the ball ends on the rack should be pointing in opposite directions.

BAG A

REMOVE THESE PARTS FOR: Step 2



3856, qty 4 washer



3856, qty 2 rack post shim



6291, qty 2 4-40 X 1/4 screw



6222, qty 2 nylon locknut

TOOLS USED

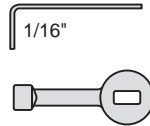

3856, qty 2 rack post



3856, qty 4 1/8 x 1/4 steering rack bushing



FT KIT ONLY 3971*, qty 4 1/8 x 1/4 steering rack bearing



3850, 3849*, qty 1 chassis NOT IN BAG A

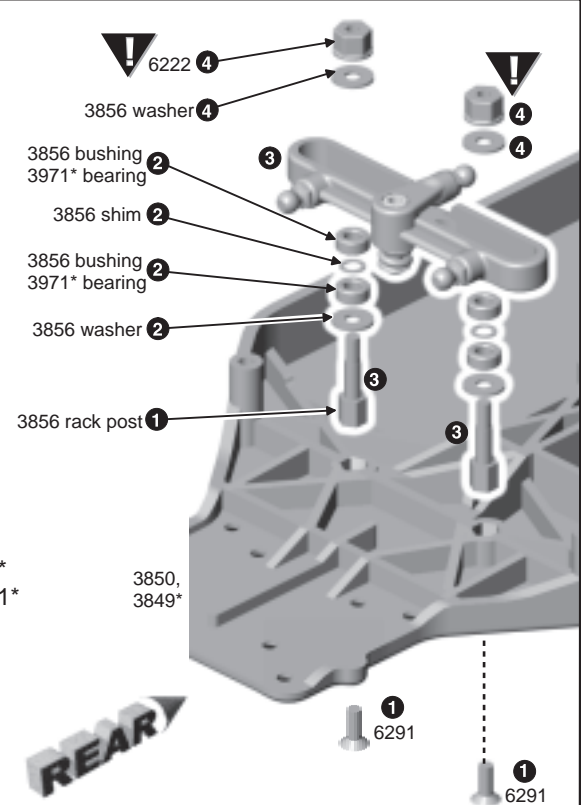

step 2

RACK TO CHASSIS ASSEMBLY

- 1 Install the two #3856 rack posts to the chassis with two #6291 screws.
- 2 Slide one #3856 washer, one #3856 steering rack bushing (3971* bearing), one #3856 rack post shim and one #3856 bushing (3971* bearing) onto the rack post. Repeat for the other post.
- 3 Place the rack assembly over the rack posts.
- 4 Add two #3856 washers, then the two #6222 nylon locknuts.

! Tighten each nut down until the rack does not move side-to-side freely. Then loosen the nuts 1/4 turn or until the rack moves freely.

BAG B

REMOVE THESE PARTS FOR: Steps 1- 2



3865, qty 4 set screw

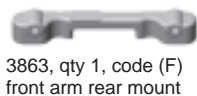

3863, qty 1, code (F) front arm rear mount

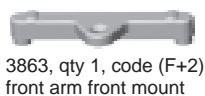

3863, qty 1, code (F+2) front arm front mount

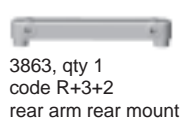

3863, qty 1 code R+3+2 rear arm rear mount



3863, qty 1, code (R) rear arm front mount

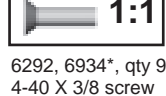

6292, 6934*, qty 9 4-40 X 3/8 screw



3860, 3861*, qty 2 front arm



3851, qty 1 front bumper



3890, 3891*, qty 2 rear arm



3900, qty 1 rear bumper



3866, qty 4 inner hinge pin

TOOLS USED

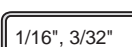

droop gauge

step 1

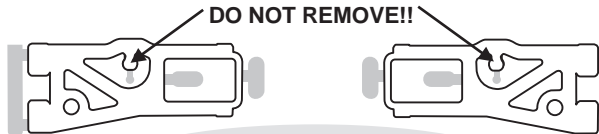

FRONT ARM ASSEMBLY

- 1 Install a #3865 set screw into the #3860 (3861*) front arms, right and left sides. Thread the set screws into the arms until the set screws are flush with the top of the arm. We will adjust them in step 3.
- 2 Attach the #3863 front arm rear mount (with the "F" molded into mount--see below for location) to the chassis with two #6292 (6934*) screws.
- 3 Attach the #3863 front arm front mount (with the "F+2" molded into the mount) to the #3851 bumper with one #6292 (6934*) screw.
- 4 Slide the #3866 inner hinge pins through the #3860 (3861*) front arms. Slide the pins with the arms into the front arm rear mount.
- 5 Align the front arm front mount and bumper with the two hinge pins and slide together. Tighten it down with two #6292 (6934*) screws.

! By changing arm mounts you can adjust for kickup and anti-dive. For more information about kickup and anti-dive settings, see the tuning section at the rear of the manual.

WHERE TO FIND THE ARM MOUNT CODE
(See page 20 for full explanation of arm mount codes)

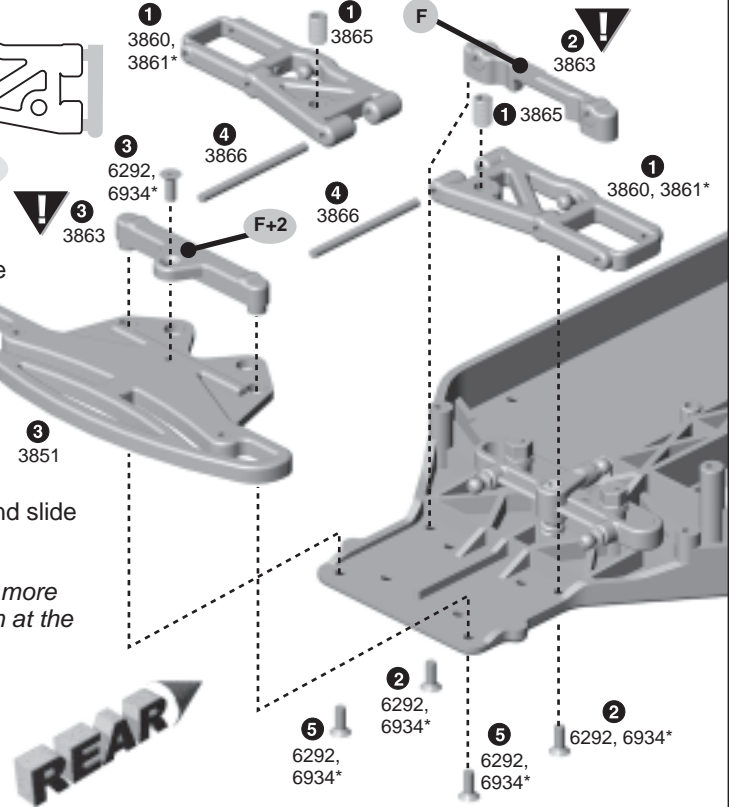

step 2

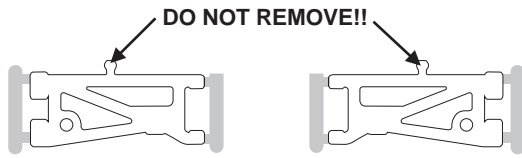

REMOVE GRAY AREAS WHERE SHOWN
BE CAREFUL NOT TO REMOVE THE BALLS!!
Remove flashing so balls are perfectly smooth.

REAR ARM ASSEMBLY

- 1 Install a #3865 10-32 set screw into the #3890 (3891*) rear arms, right and left until the set screws are flush with the top of the arms. We will adjust them in step 3.
- 2 Attach the #3863 rear arm front mount (with the "R" molded into mount--see below for location) to the chassis with two #6292 (6934*) screws.
- 3 Slide the #3866 inner hinge pins through the #3890 (3891*) rear arms. Slide the pins with the arms into the #3863 rear arm front mount.
- 4 Place the #3863 rear arm rear mount (with the "R+3+2" molded into the mount) on the #3900 rear bumper. Align the rear arm mount and bumper with the two hinge pins and slide together. Tighten it down with two #6292 (6934*) screws.

! By changing arm mounts you can adjust toe-in and anti-squat. For more information about the rear toe-in and anti-squat settings, see the tuning section at the rear of the manual.

WHERE TO FIND THE ARM MOUNT CODE

(See page 20 for full explanation of arm mount codes)

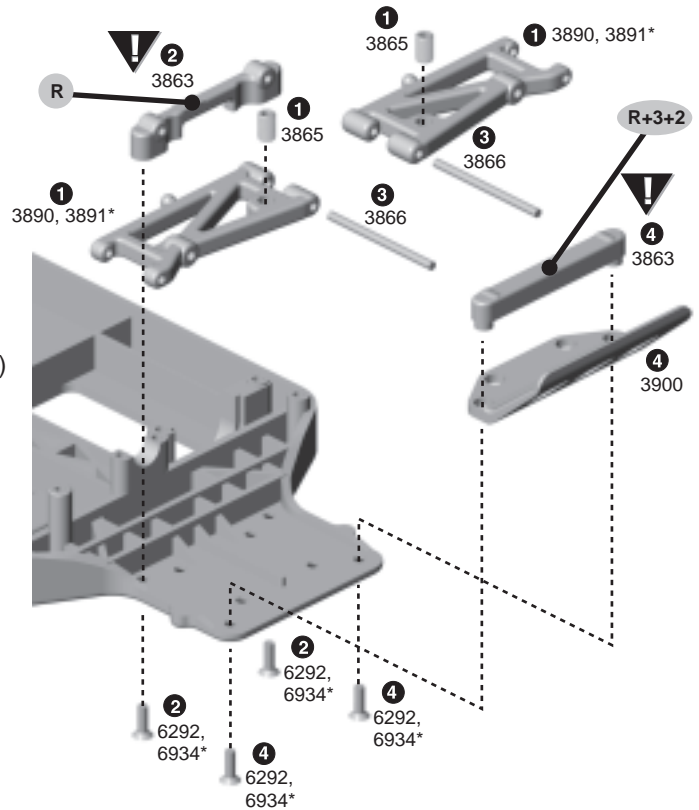

step 3

SETTING DROOP

- 1 Place the supplied #3987 droop gauge on a flat surface on its edge as shown. Rest the bottom of the chassis on the gauge as shown, making sure the screws are not resting on the gauge.
- 2 Slide the gauge out so the front arm rests on step 6.
- 3 With your 3/32" Allen wrench, adjust the set screw so the outer part of the arm just touches the step. Adjust both front arms.
- 4 Slide the gauge to the rear arms and repeat, but the rear arms will rest on step 4.

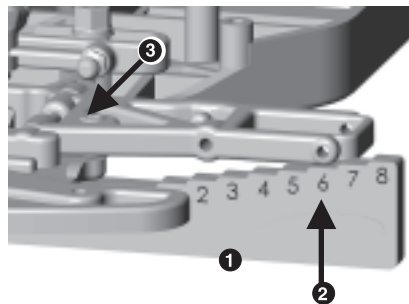

FRONT ARM SETTING

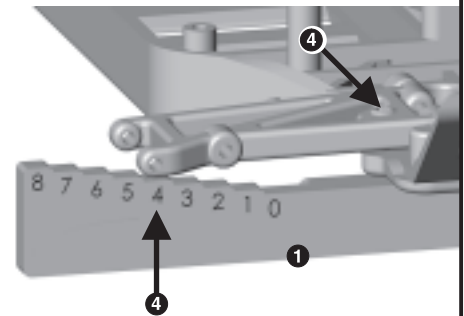

REAR ARM SETTING

NOTE: 1/8 turn equals 1/2 step in change.
1/4 turn equals 1 step change.

RACER'S TIP: By using a ball end 3/32" driver it is easier to adjust the droop set screws.

BAG C

REMOVE THESE PARTS FOR:
Steps 1- 5



6573, qty 4
diff thrust washer



3907, qty 2
3/16 x 5/16 bushing
unflanged

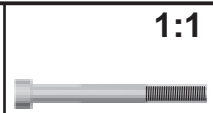

6575, qty 2
diff bolt

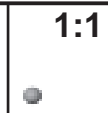

6581, qty 24
3/32 diff ball
large

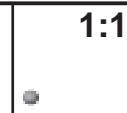

6574, qty 12
5/64 thrust ball
small



3904, qty 2
2-56 locknut



3908, qty 2
long outdrive

3908, qty 2
short outdrive

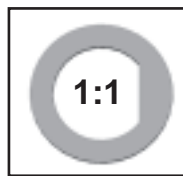

3906, qty 2
D-drive ring



3914, qty 2
differential ring gear



6591, qty 1
Stealth diff lube



6588, qty 1
black grease



6582, qty 2
diff spring,
gray

TOOLS USED

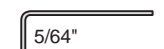

step 1

THRUST BALL ASSEMBLY

- 1 Hold the #6575 diff bolt with your 5/64" Allen wrench and slide one #6573 washer onto the #6575 diff bolt.
- 2 Apply a generous amount of #6588 black grease to the washer on the side facing away from the bolt head.
- 3 Place six #6574 thrust balls into the grease against the #6575 bolt and washer. Add the other #6573 washer. The grease will hold the balls in place during assembly, sandwiched between the washers.



step 2

SPRING

- 1 With a pair of pliers, compress the #6582 diff spring a few times.
- 2 Slide the spring onto the bolt against the thrust assembly.

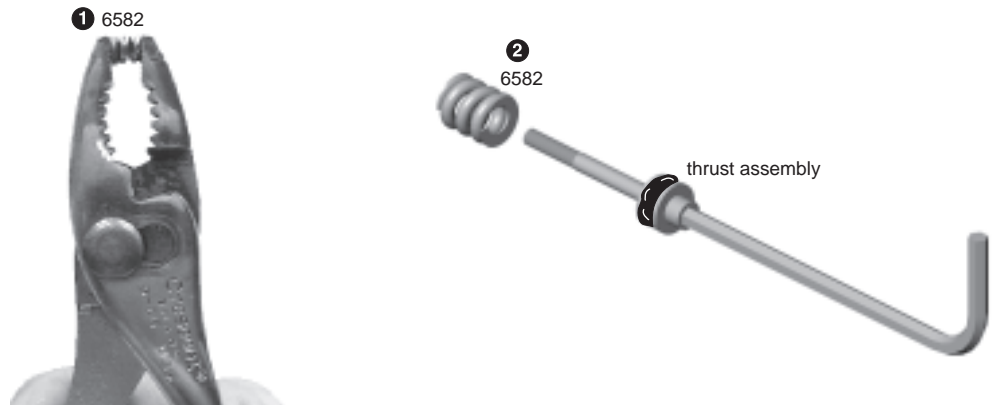

step 3

LONG HUB ASSEMBLY

- 1 Insert the thrust assembly into the #3908 long hub.
- 2 Add a light coat of #6591 Stealth lube to the long hub face where shown.
- 3 Place a #3906 diff ring on the hub, lining up the flats on the ring and hub.
- 4 Insert #3907 bushing into the long hub.

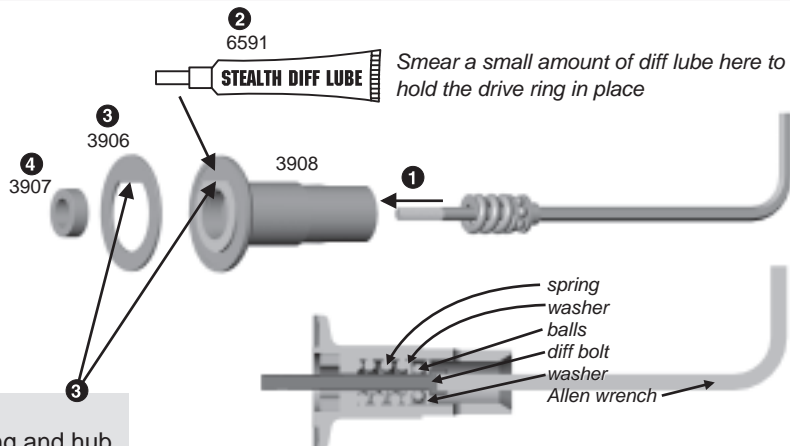

CAUTION!!
Make sure you line up the flats on the diff ring and hub

step 4

SHORT OUTDRIVE

- 1 Add a small amount of #6591 Stealth diff lube to the #3904 locknut where shown to help hold it in place. Insert the #3904 2-56 locknut into the #3908 short outdrive. The nut should fit flat inside the hex shape.

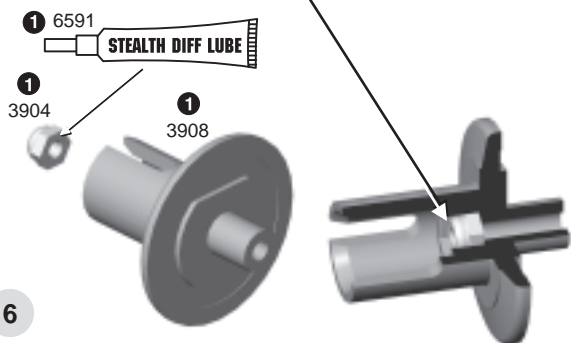

step 5

DIFFERENTIAL RING GEAR

- 1 Trim any burrs from the inside of the gear with a hobby knife.
- 2 Add a generous amount of #6591 diff lube to the #3914 ring gear ball holes and push in the twelve #6581 diff balls. Then push back in the lube that came out.

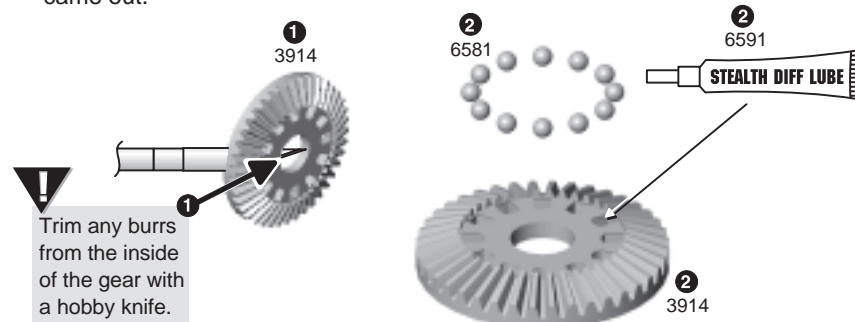

BAG C

REMOVE THESE PARTS FOR:
Steps 6-8

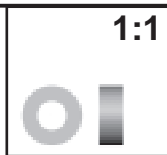

3907, qty 2
3/16 x 5/16
bushing, unflanged



FACTORY TEAM ONLY
6903*, qty 4
3/8 x 5/8 bearing
Teflon sealed, unflanged



3976, qty 4
3/8 x 5/8 bearing
rubber sealed, unflanged



3911, qty 2
outdrive shim



3908, qty 2
diff cover

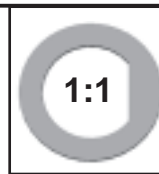

3906, qty 2
D-drive ring

TOOLS USED

5/64

step 6

SHORT HUB ASSEMBLY

- 1 Add a light coat of #6591 Stealth lube to the #3908 short hub face.
- 2 Place a #3906 diff ring on the hub, lining up the flats on the ring and hub.
- 3 Insert one #3907 bushing onto the short hub.
- 4 Push the #3908 short hub assembly into the back side of the differential ring gear assembly.



CAUTION!!

Make sure you line up the flats on the diff ring and hub

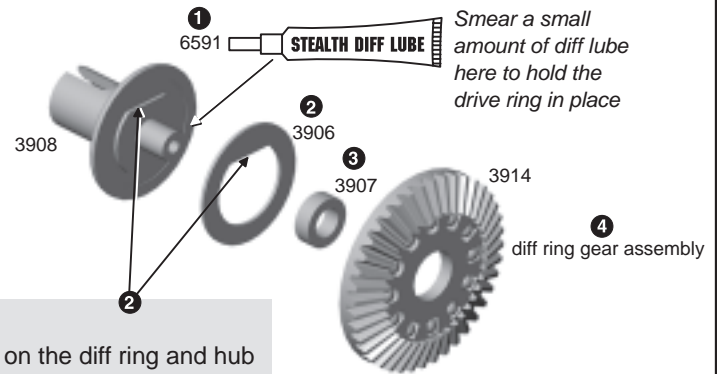

step 7

DIFF ASSEMBLY

- 1 Insert the long hub assembly into the short hub assembly, making sure you line up the bolt in the hub and the bolt threads into the #3904 locknut.

CHECK ALIGNMENT OF THE HUBS

- 2 Tighten the diff with your 5/64" Allen wrench, but not completely.
- 3 Screw in the diff bolt a few turns then stop to rotate the diff hubs in opposite directions. Then screw in the bolt some more. Follow this procedure to check proper alignment of the parts. The following note clarifies this.

READ THE FOLLOWING CAREFULLY.

As you tighten the diff bolt, pay close attention to the feeling when the spring is fully compressed. Do not overtighten the bolt. When you feel the spring fully compressed, loosen the diff bolt 1/2 turn. No more, no less. After you have driven the car for one pack, recheck the diff adjustment as above so that when you feel the spring fully compressed, loosen the diff bolt 1/2 turn. Never adjust the diff any other way.

- 4 Now assemble the second diff the same way.



Rotate the hubs in opposite directions several times in between screwing in the diff bolt.



IT IS EXTREMELY IMPORTANT TO USE THE EXACT AMOUNT OF SHIMS SUGGESTED IN THESE STEPS.

step 8

FINAL OUTDRIVE ASSEMBLY

- 1 Insert the #3908 diff bolt cover into the long hub.
- 2 Press one #3911 outrdrive shim on the long hub.
- 3 Place one #3976 bearing over each outrdrive hubs.

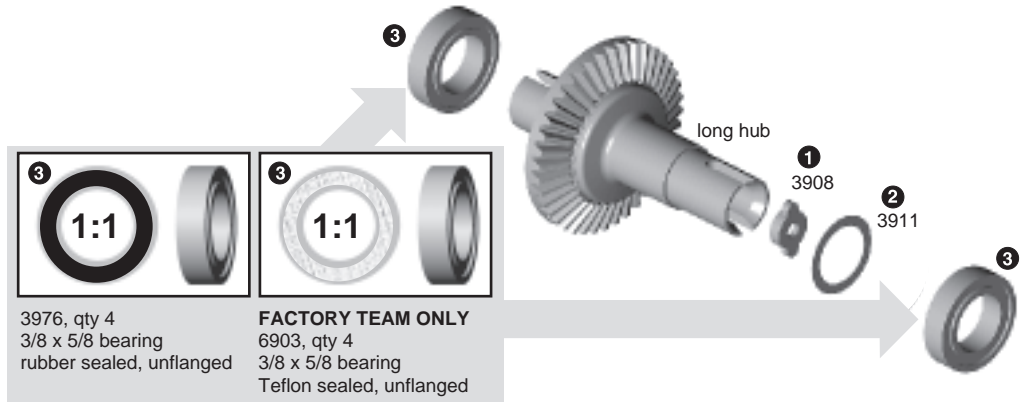

BAG C

REMOVE THESE PARTS FOR:
Steps 9-12

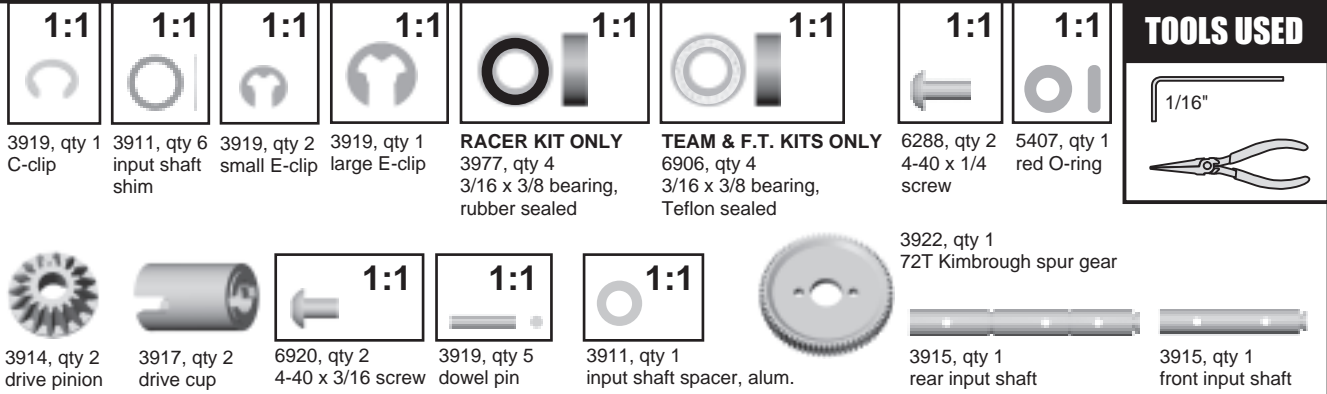

step 9

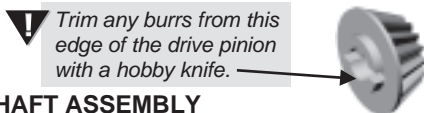

FRONT INPUT SHAFT ASSEMBLY

- 1 Install and center the #3919 dowel pin into the #3915 front input shaft.
- 2 Trim burrs from the drive pinion edge where shown above. Slide the #3914 drive pinion onto the input shaft. **Make sure the dowel pin aligns perfectly with the slot in the pinion.**
- 3 Add the #3919 small E-clip.
- 4 Slide three #3911 input shaft shims and one #3977 or #6906 bearing onto the #3915 input shaft.
- 5 Slide the second #3977 or #6906 bearing onto the input shaft.
- 6 Install and center the #3919 dowel pin into the input shaft.
- 7 Slide a #3917 drive cup onto the end of the input shaft.
- 8 Tighten it down with one #6920 screw.

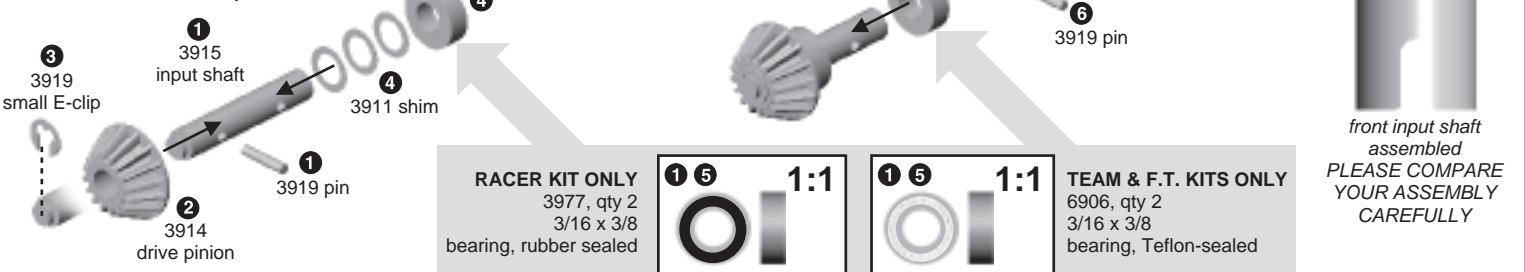

step 10

REAR INPUT SHAFT ASSEMBLY

- 1 Attach the #3919 C-clip to the #3915 rear input shaft. (We've included an extra C-clip in case you lose one.)
- 2 Install the #3919 dowel pin into the input shaft.
- 3 Slide on the #3917 gear adapter.
- 4 Add the #3919 large E-clip.

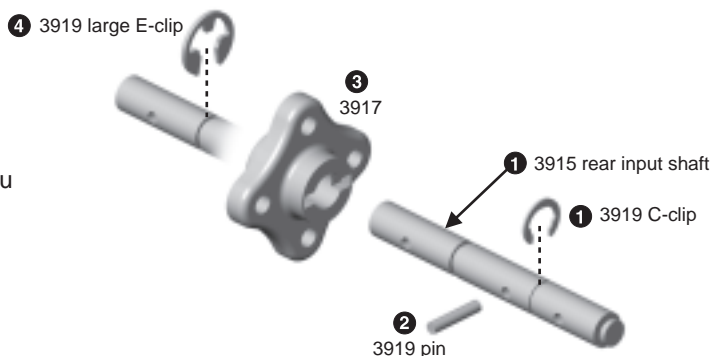

step 11

REAR INPUT SHAFT ASSEMBLY

- Slide one #3977 or #6906 bearing and one #3911 input shaft spacer onto the #3915 rear input shaft.
- Install and center one #3919 dowel pin into the input shaft.
- Slide a #3917 drive cup onto the input shaft.
- Tighten it down with one #6920 screw.
- Slide in a #5407 O-ring into the #3917 drive cup.

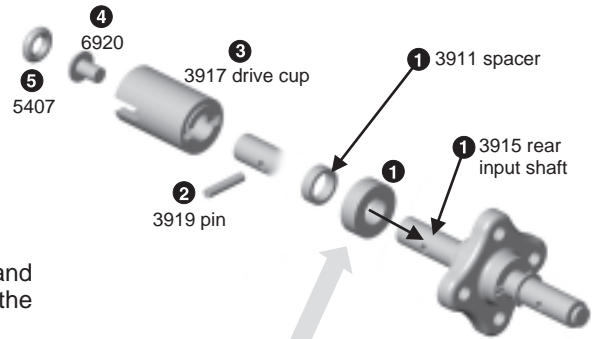

- Slide one #3977 or #6906 bearing and three #3911 input shaft shims onto the #3915 rear input shaft.
- Install and center a #3919 dowel pin into the input shaft.
- Slide a #3914 drive pinion onto the end of the input shaft. **Make sure the dowel pin aligns perfectly with the slot in the pinion.**
- Add a #3919 small E-clip.

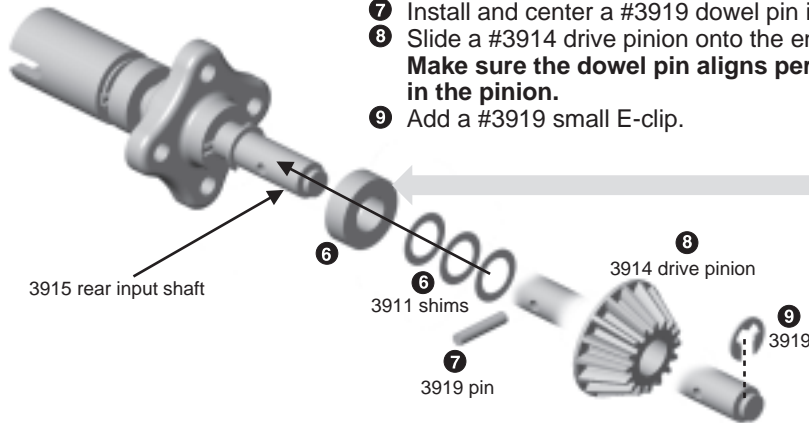

RACER KIT ONLY
3977, qty 2
3/16 x 3/8
bearing, rubber sealed



TEAM & F.T. KITS ONLY
6906, qty 2
3/16 x 3/8
bearing, Teflon sealed

step 12

REAR INPUT SHAFT ASSEMBLY

- Slide the #3922 spur gear over the drive cup and align it on the #3917 gear adapter.
- Tighten down the spur gear with two #6288 screws.

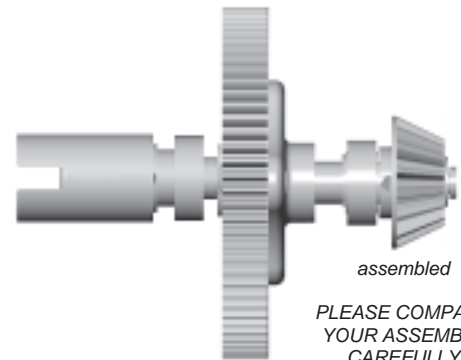
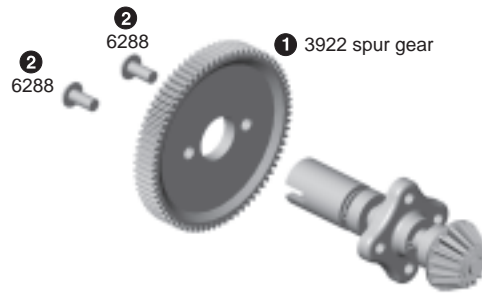

BAG C

TOOLS USED

REMOVE THESE PARTS FOR:
Steps 13-15



3910, qty 2
lower transmission case



3910, qty 1
upper transmission case



6292, 6934*, qty 8
4-40 x 3/8 screw



6924, 6860*, qty 6
4-40 x 3/8 screw



6591, qty 1
Stealth diff lube

1/16, 3/32

step 13

FRONT TRANSMISSION ASSEMBLY, LOWER HALF

- Attach the #3910 lower transmission case to the chassis with four #6292 screws.

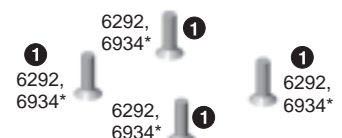
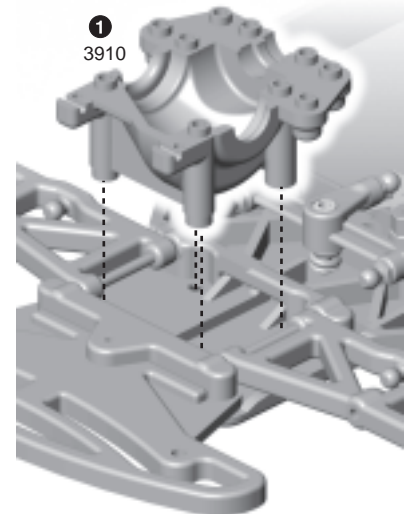

step 14

FRONT TRANSMISSION ASSEMBLY

- 1 Install the diff assembly and front input shaft assembly into the lower transmission case.
- 2 Add a small amount of #6591 diff lube to the front side of the ring rear and pinion gear.
- 3 Attach the #3910 upper transmission case to the lower case with six #6924 (6860*) screws.

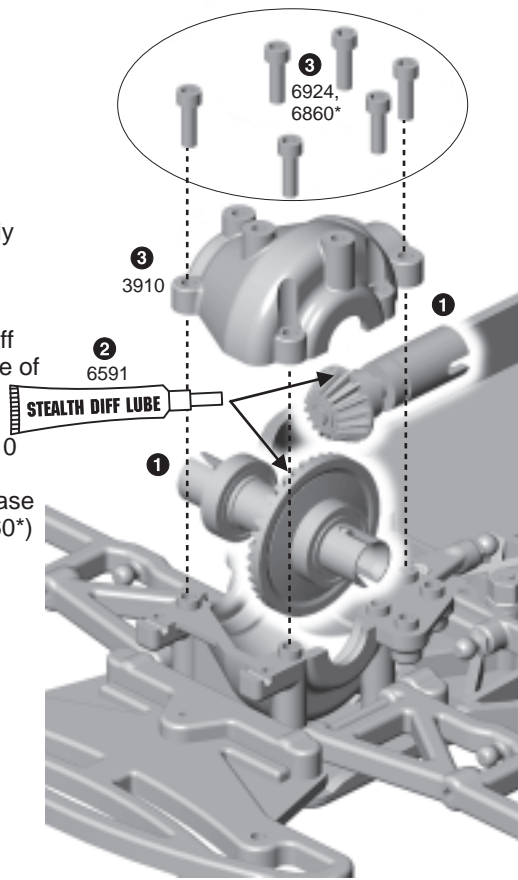

step 15

REAR TRANSMISSION ASSEMBLY, LOWER HALF

- 1 Attach the #3910 lower transmission case to the chassis with four #6292 (6934*) screws.

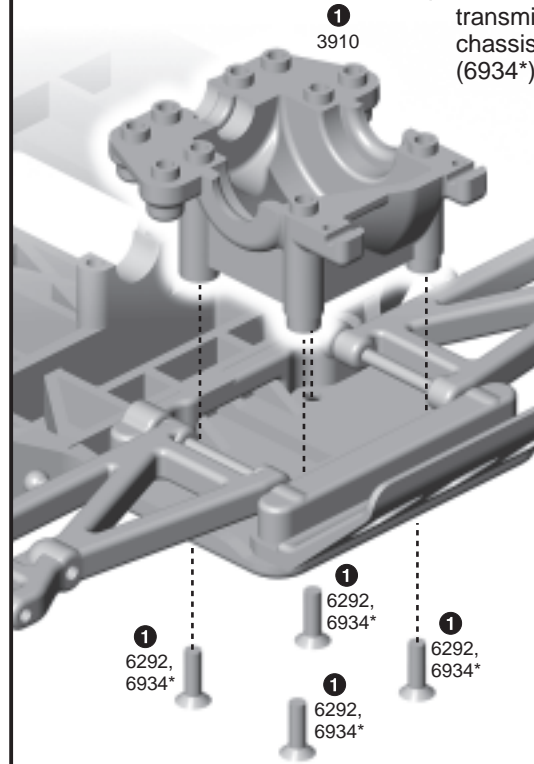

BAG C

1:1

REMOVE THESE PARTS FOR: Steps 16-18

6924, 6860*, qty 8
4-40 x 3/8 screw

3924, qty 1
driveshaft

3910, qty 1
upper transmission case

3917, qty 1
drive bearing cap

STEALTH DIFF LUBE
6591, qty 1
Stealth diff lube

TOOLS USED

3/32

step 16

REAR TRANSMISSION ASSEMBLY

- 1 Install the diff assembly into the lower transmission case.
- 2 Place one end of the #3924 drive shaft into the drive cup on the rear input shaft assembly.
- 3 Install the opposite end of the drive shaft into the front drive cup. Set the rear input shaft into place.
- 4 Add a small amount of #6591 diff lube to the front side of the ring gear and pinion

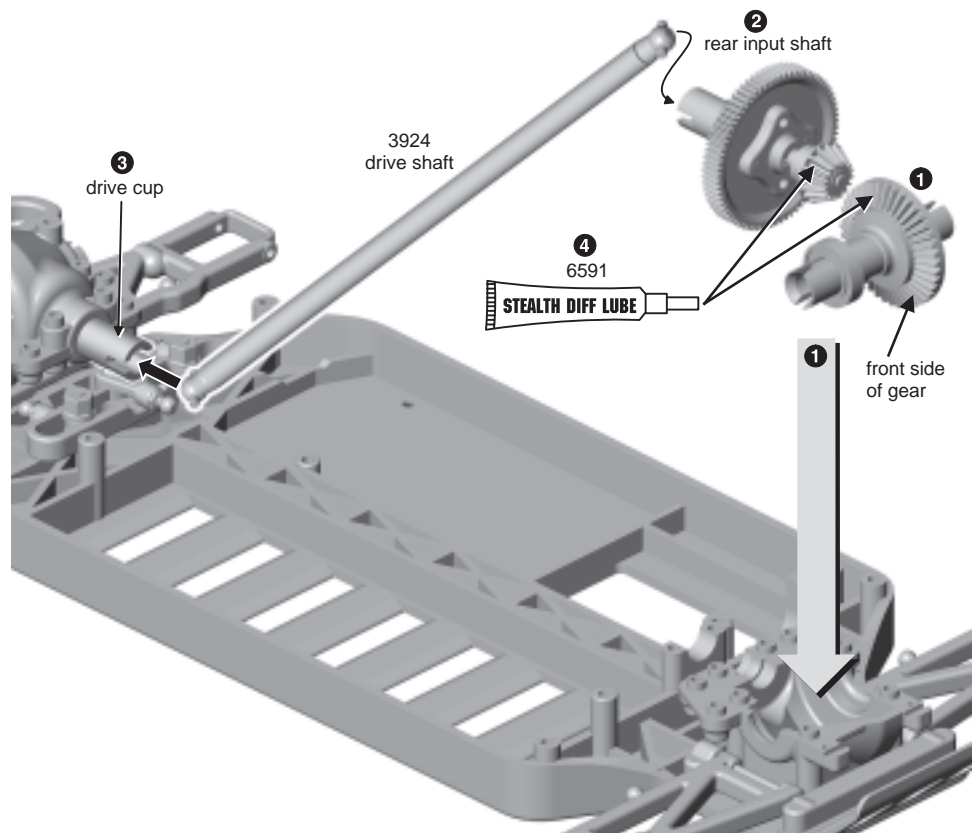

step 17

REAR TRANSMISSION CASE

- 1 Attach the #3910 upper transmission case to the lower case with six #6924 (6860*) screws.

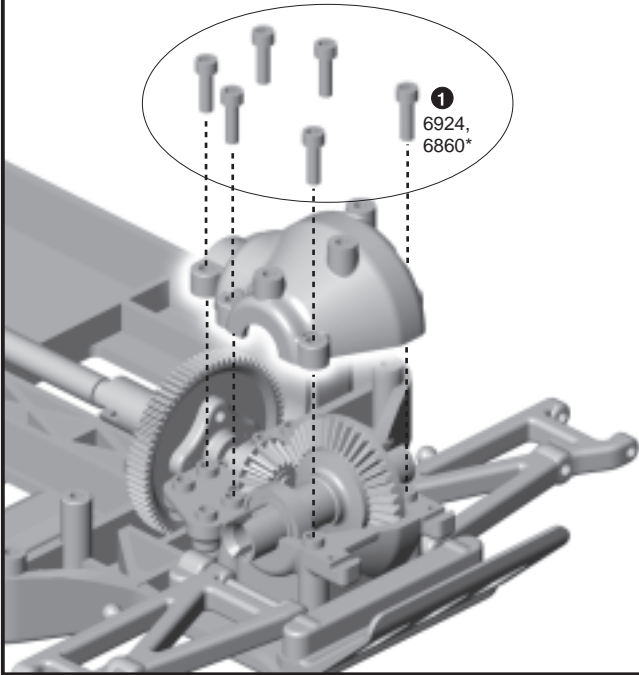

step 18





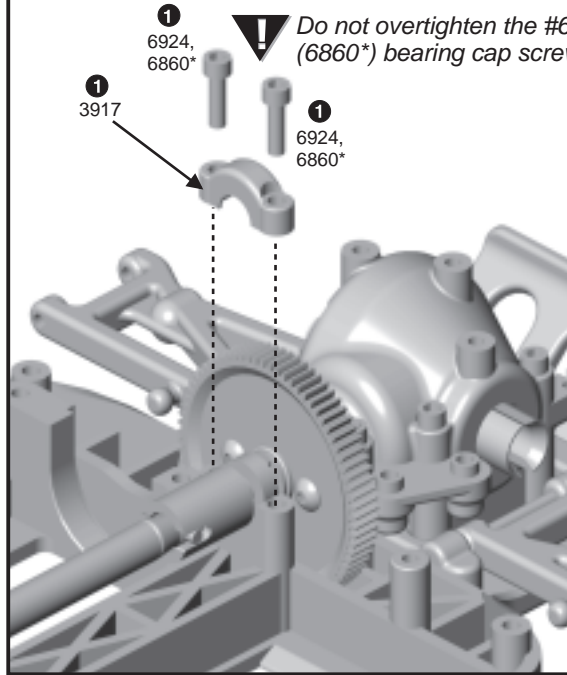

DRIVE BEARING CAP

- 1 Align the #3917 drive bearing cap over the bearing and attach with two #6924 (6860*) screws where shown.

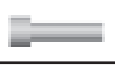

BAG D

REMOVE THESE PARTS FOR:
Steps 1-4

1:1 	1:1 	1:1 	1:1 	1:1 
3858, qty 4 long special ball end, black	6272, qty 4 ball end dust cover	6924, 6860*, qty 6 4-40 x 3/8 screw	7260, qty 8 4-40 plain nut	7413, qty 4 4-40 x 3/4 screw
				
3881, 3882*, qty 1 front shock tower	3895, 3896*, qty 1 rear shock tower			

TOOLS USED

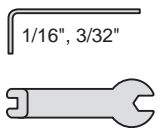

step 1

FRONT SHOCK TOWER ASSEMBLY

- 1 Install the two #7413 screws through the outer holes on the #3881 (3882*) front shock tower. Then thread on the #7260 nuts.
- 2 Attach the #3858 ball ends and #7260 nuts through the lower inner holes on the shock tower.
- 3 Add a #6272 dust cover to the ball ends.

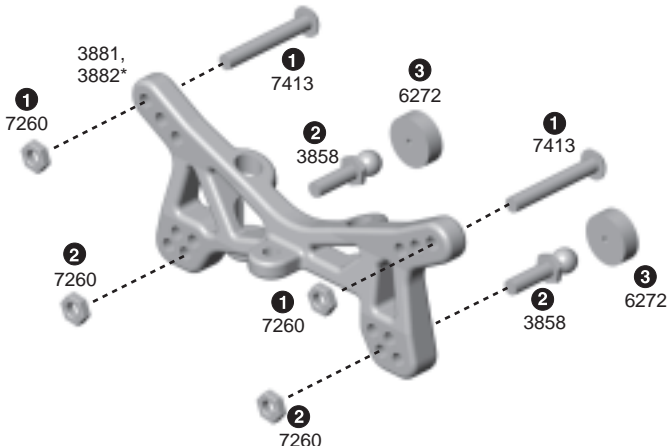

step 2

FRONT SHOCK TOWER ASSEMBLY

- 1 Attach the #3881 (3882*) front shock tower to the upper transmission case with three #6924 (6860*) screws.

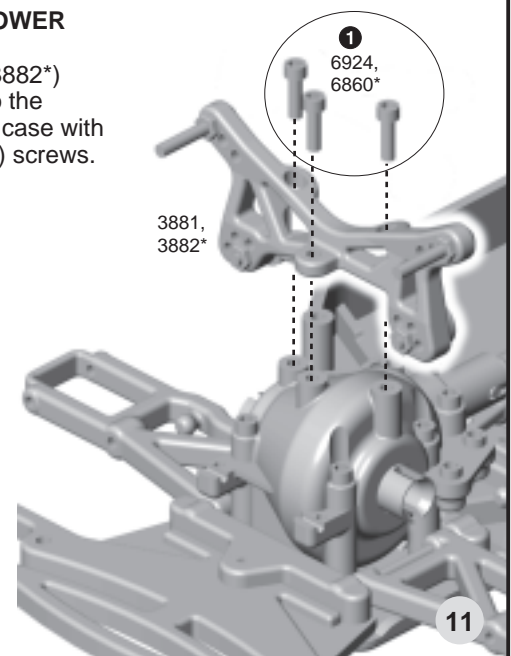

step 3

REAR SHOCK TOWER ASSEMBLY

- 1 Install the two #7413 screws through the outer holes on the #3895 (3896*) rear shock tower. Then thread on the #7260 nuts.
- 2 Attach the #3858 ball ends and #7260 nuts through the lower inner holes on the shock tower.
- 3 Add a #6272 dust cover to the ball ends.

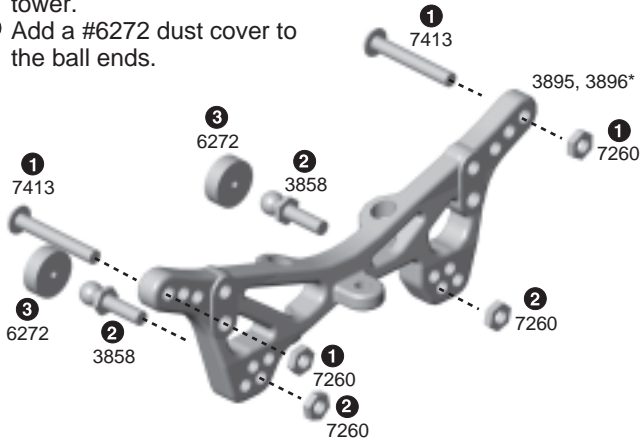

step 4

REAR SHOCK TOWER ASSEMBLY

- 1 Attach the #3895 (3896*) rear shock tower to the upper transmission case with three #6924 (6860*) screws.

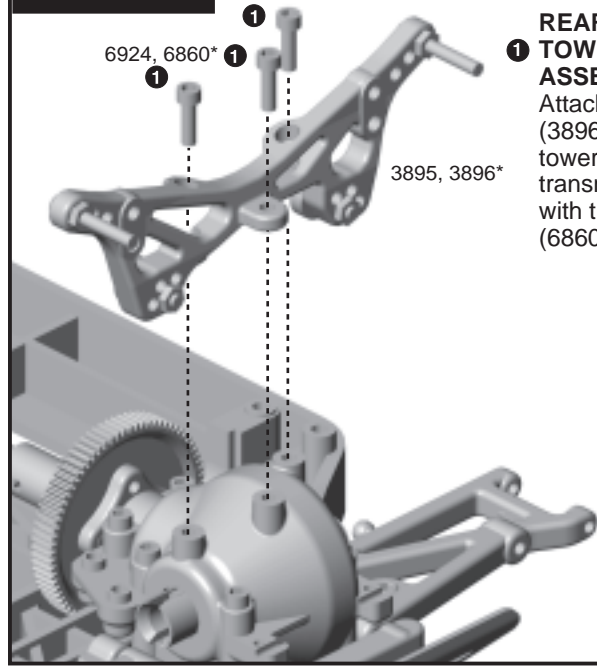

BAG E

REMOVE THESE PARTS FOR: Steps 1-4

1:1 7381, qty 4 CVD coupling	1:1 7381, qty 4 CVD cross pin	1:1 7381, qty 4 CVD set screw	1:1 7260, qty 2 4-40 plain nut	1:1 6272, qty 2 ball end dust cover	1:1 7369, qty 2 CVD roll pin	1:1 7368, qty 2 shim
1:1 RACER KIT ONLY 3977, qty 4 3/16 x 3/8 rubber sealed bearing	1:1 TEAM & F.T. KITS ONLY 6906, qty 4 3/16 x 3/8 Teflon sealed bearing	1:1 6273, qty 2 long ball end natural color	1:1 3858, qty 2 long special ball end, black	1:1 3965, qty 2 bearing spacer	1:1 3875, qty 2 4-40 x 11/32 screw with shoulder	
1:1 3868, 3869*, qty 2 front block carrier (0° caster block)	1:1 3876, 3877*, qty 2 front steering block	1:1 3887 or 3888, qty 4 CVD bone	1:1 3886, qty 4 CVD axle	1:1 6588, qty 1 black grease	1:1 3866, qty 2 front outer hinge pin	1:1 3862, qty 2 5-40 set screw gold
					1:1 3874, qty 4 block carrier bushings	

TOOLS USED

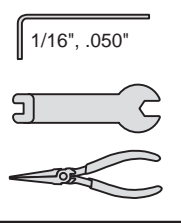

step 1

MIP CVD ASSEMBLY

- 1 Spread some Associated #6588 black grease inside the axle hole where shown, then on the coupling and insert the coupling into the axle.
- 2 Slide the axle into the dogbone, aligning the cross holes.
- 3 Insert the cross pin, making sure it is evenly spaced on both sides of the bone.
- 4 Add the MIP thread lock to the set screw. Angle and turn the CVD so the set screw can be screwed in with the Allen wrench.
- 5 Repeat steps for the three remaining CVD's.

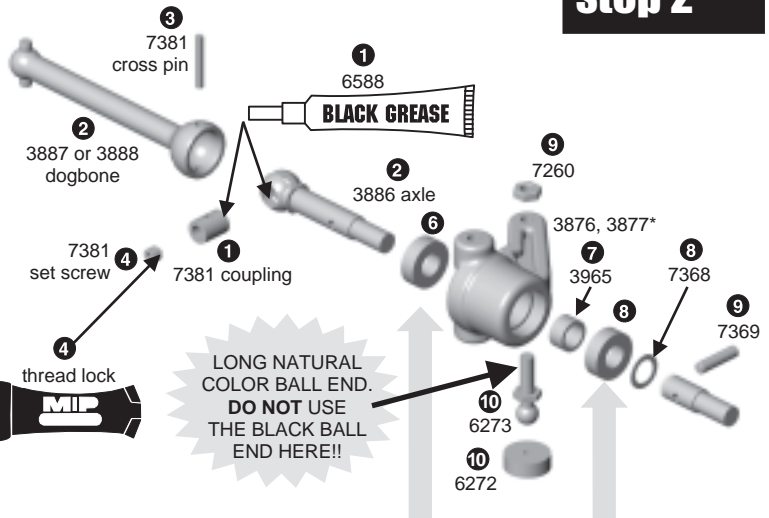

step 2

STEERING BLOCK ASSEMBLY

- 6 Install one #3977 or #6906 bearing on the axle. Slide the axle assembly into the back of the #3876 (3877*) steering block.
- 7 Slide in a #3965 bearing spacer.
- 8 Install the second #3977 or #6906 bearing into the steering block and on the axle, followed by one #7368 thin spacer.
- 9 Insert the #7369 roll pin into the axle.
- 10 Thread the natural color #6273 ball end into the bottom of the #3876 steering block and add the #7260 plain nut. Add a #6272 dust cover over ball end.
- 11 Repeat steps for the right side, installing the steering block ball end in the opposite way.

1:1 RACER KIT ONLY 3977, qty 4 3/16 x 3/8 rubber sealed bearing	1:1 TEAM & F.T. KITS ONLY 6906, qty 4 3/16 x 3/8 Teflon-sealed bearing
--	---



step 3

LEFT BLOCK CARRIER ASSEMBLY

- 1 Break through and push out the thin webbing in the holes with your 2mm Allen wrench before assembly.
- 2 Insert two #3874 steering block bushings and steering block assembly into the #3868 (3869*) block carrier as shown.
- 3 Make sure the CVD dogbone goes through the hole of the block carrier as shown.
- 4 Align the steering block and block carrier and thread a #3858 long special ball end on top, and a #3875 screw on the bottom. Add a #6272 dust cover over the ball end.
- 5 Insert the 3862 5-40 set screw into the bottom of the block carrier. Do not thread it all the way in. We will tighten it in the next step.
- 6 Repeat steps for the right side.

step 4

ATTACH BLOCK CARRIER ASSEMBLY

- 1 Place the left block carrier assembly between the arm holes. Insert the #3866 front outer hinge pin through the arm holes.
- 2 Tighten the set screw of step 3, #5, locking the hinge pin in place. DO NOT OVERTIGHTEN!
- 3 Insert the universal dogbone into the slots of the outdrive hub.
- 4 Now install the block carrier for the other side.

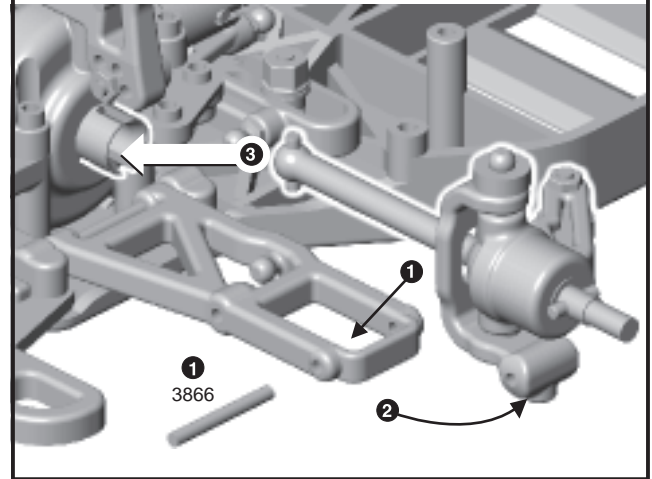

BAG E

REMOVE THESE PARTS FOR: Steps 5-6



3876, 3977*, qty 2 rear hub carrier



RACER KIT ONLY
3977, qty 4
3/16 x 3/8
rubber sealed bearing



F.T. & TEAM KITS
6906, qty 4
3/16 x 3/8
Teflon sealed bearing



7260, qty 2
4-40 plain nut



6272, qty 2
ball end dust cover

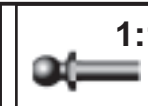

3858, qty 2
long special ball end, black



7368, qty 2
3/16 axle shim



7369, qty 2
CVD roll pin

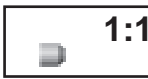

3862, qty 2
5-40 set screw, gold



4187, qty 4
washers, plastic



3866, qty 2
rear outer hinge pin



3965, qty 2
bearing spacer

TOOLS USED

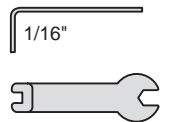

step 5

REAR HUB CARRIER ASSEMBLY

- 1 Break through and push out the thin webbing in the holes of both hub carriers with your 2mm Allen wrench (as shown above). Install one #3977 or #6906 bearing onto the axle. Slide the axle assembly into the back of the #3876 (3877*) rear hub carrier.
- 2 Slide in the #3965 bearing spacer.
- 3 Install the second #3977 or #6906 bearing into the hub carrier and onto the axle followed by one #7368 axle shim.
- 4 Insert the #7369 roll pin into the axle.
- 5 Thread on the #3858 long special ball end into the front of the hub carrier as shown and add the #7260 plain nut. Add a #6272 dust cover over the ball end.
- 6 Repeat steps for the right side. See assembly picture at right.



1 Break through and push out the thin webbing in the holes with your 2mm Allen wrench before assembly.

LEFT REAR HUB CARRIER SHOWN

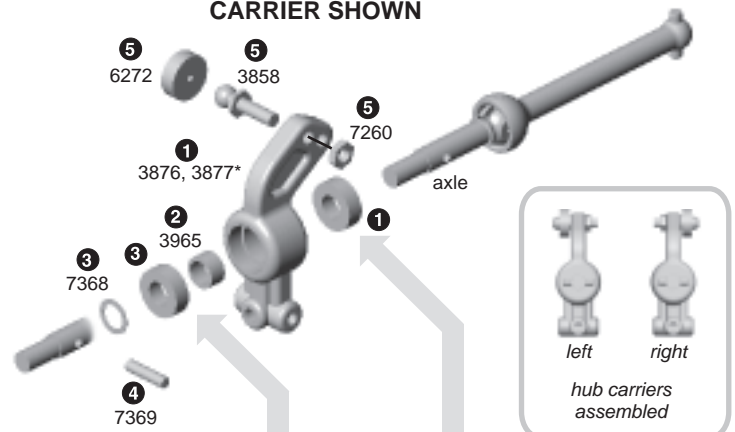

RACER KIT ONLY
3977, qty 4
3/16 x 3/8
bearing



TEAM & F.T. KITS ONLY
6906, qty 4
3/16 x 3/8
Teflon-sealed bearing

step 6

ATTACH REAR HUB CARRIER ASSEMBLY

- Place the left hub carrier between the arm holes as shown and add two #4187 spacers where shown. Insert the #3866 rear outer hinge pin through the arm and hub carrier. Thread in the #3862 5-40 set screw into the hub carrier. Tighten down the set screw, locking the hinge pin in place. **DO NOT OVERTIGHTEN!**
- Insert the universal dogbone into the slots of the outdrive hub.
- Now install the hub carrier assembly for the right side.

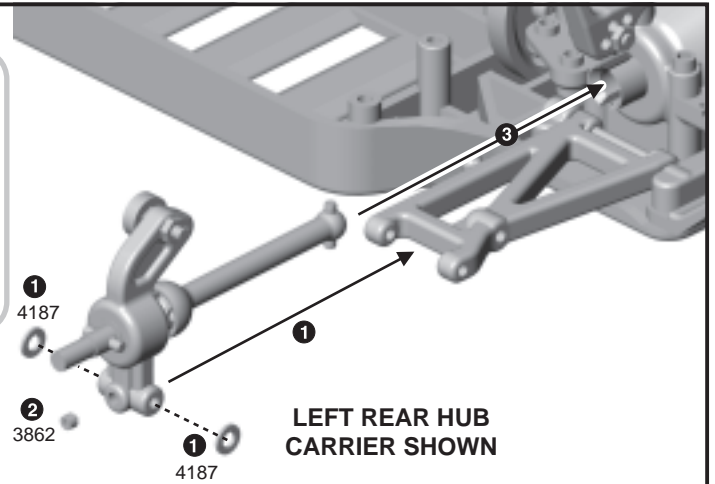
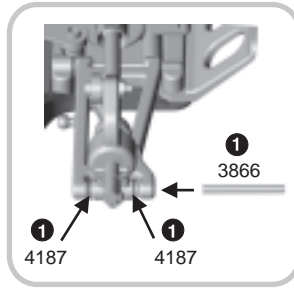

LEFT REAR HUB CARRIER SHOWN

BAG F

REMOVE THESE PARTS FOR: Steps 1-2



TEAM & F.T. KITS ONLY
1356, qty 6
blue titanium turnbuckle



3879, 3880*, qty 2
rear chassis brace



RACER KIT ONLY
3867, qty 6
steel turnbuckle

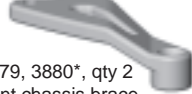

3879, 3880*, qty 2
front chassis brace

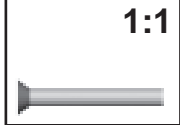

6923, qty 4
4-40 x 3/4 screw



6924, 6860*, qty 8
4-40 x 3/8 screw



6274, qty 12
ball cup

TOOLS USED

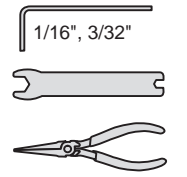

step 1

TURNBUCKLE ASSEMBLY

- Twist the #6274 ball cups onto the #1356 blue titanium turnbuckle or #3867 steel turnbuckle until you get the dimension shown for each part. Assemble all six turnbuckles.
- Snap all six turnbuckles into place where shown, making sure that all the universal bones are in the slots of the outdrive hubs.

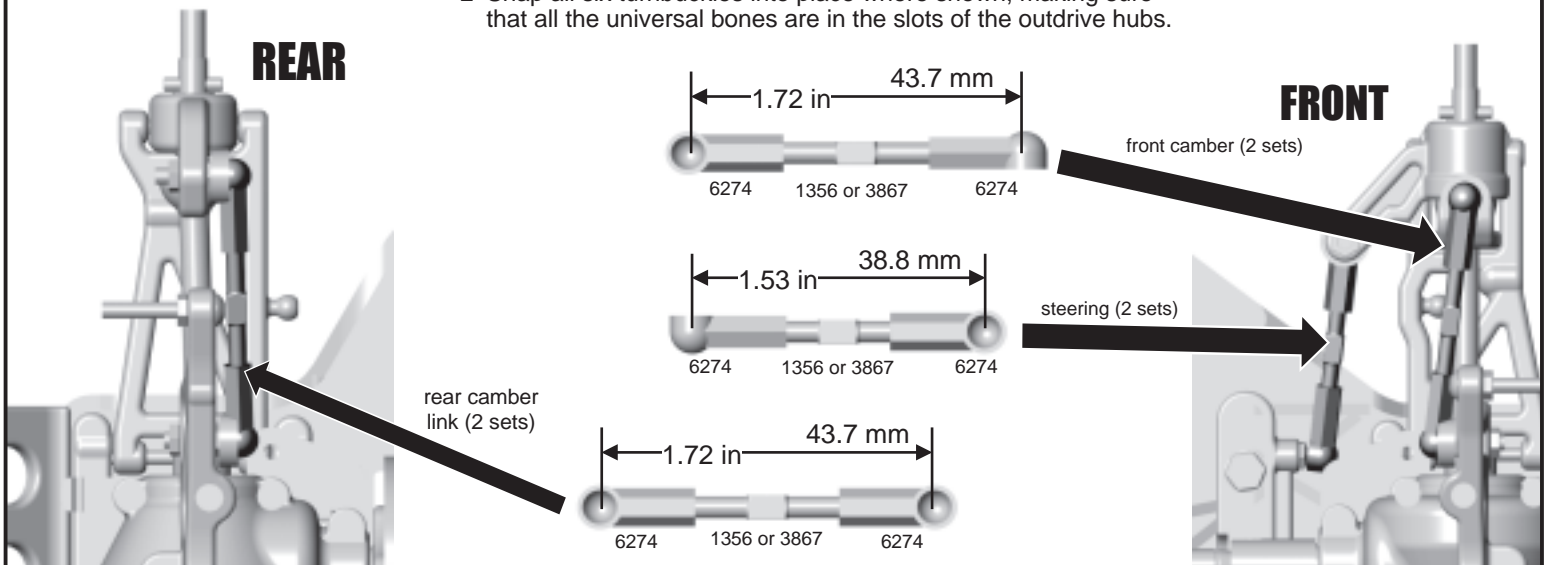

step 2

INSTALLING CHASSIS BRACE

- 1 Mount the #3879 (3880*) left front and left rear chassis braces with two #6924 (6860*) screws and one #6923 screw for each brace as shown.
- 2 Repeat step for the right side.

FRONT

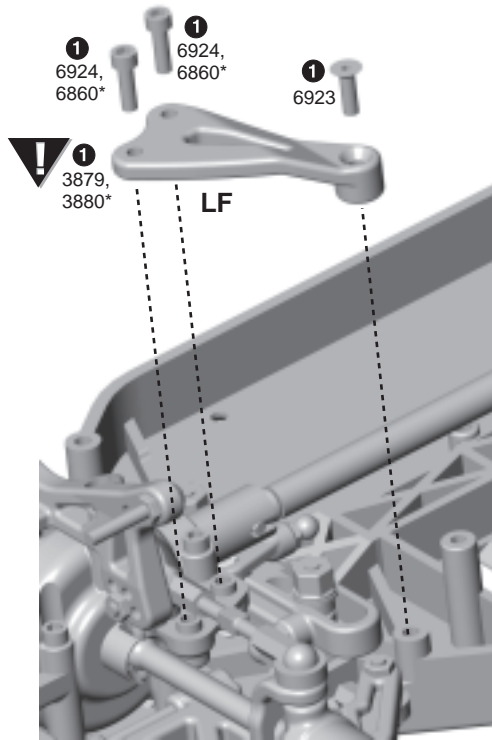

WHERE TO FIND THE CHASSIS BRACE I.D.

Each chassis brace has a molded identification that indicates where it goes on the car, as shown below.

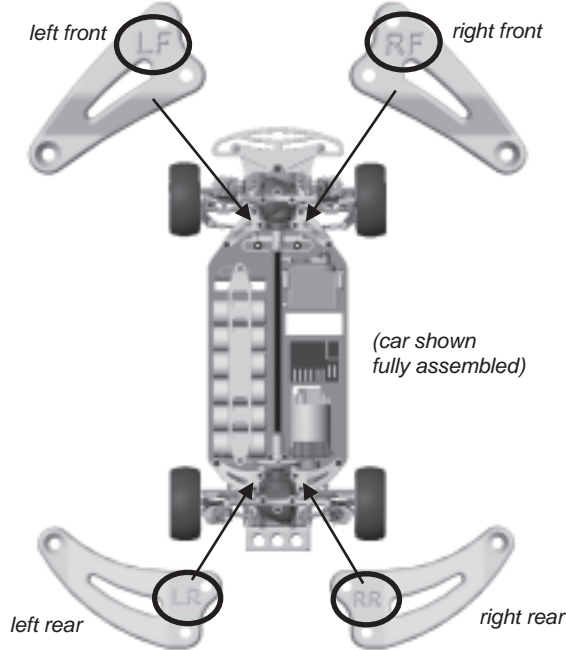

REAR

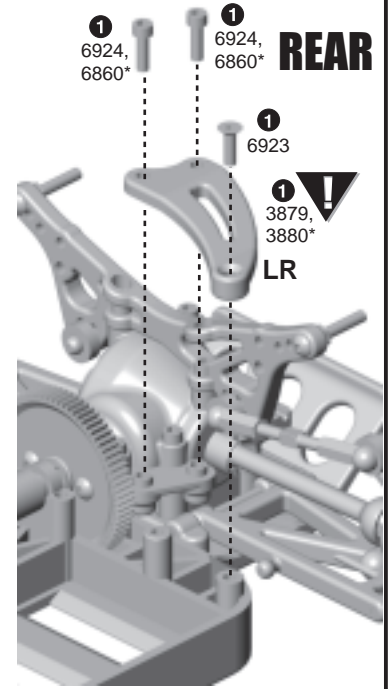

BAG G

REMOVE THESE PARTS FOR: Steps 1-4

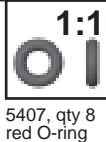

5407, qty 8 red O-ring



6299, qty 8 E-clip



8456, qty 4 VC foam



6428, qty 4 shock cap

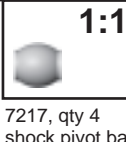

7217, qty 4 shock pivot ball

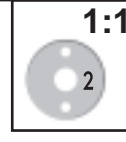

6465, qty 4 shock piston #2



6469, qty 4 large O-ring

8844, 3964*, qty 4 shock shaft

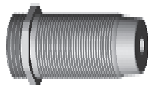

FACTORY TEAM KIT ONLY
3963*, qty 4 threaded macro shock body blue



RACER KIT ONLY
8458, qty 4 macro shock composite body



TEAM KIT ONLY
8450B, qty 4 macro shock body blue



5423, qty 1 40 wt silicone oil



7217, qty 4 shock eyelet



8456, qty 4 VC bobbin

TOOLS USED

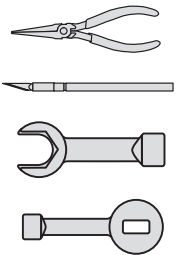

step 1

TRIM SHOCK PISTON

- 1 Burrs on the #6465 shock piston interfere with smooth shock action within the shock body. To remove from tree without creating burrs, twist up, not down. Remove four #2 shock pistons.
- 2 Remove remaining burrs carefully with a hobby knife.

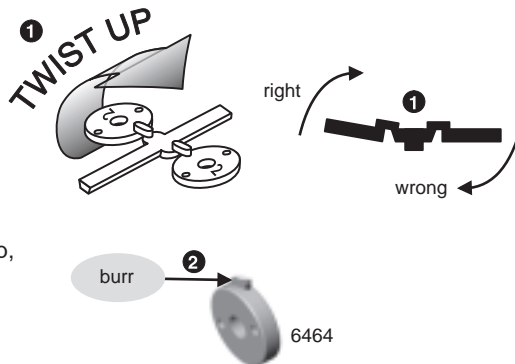

step 2

VC FOAM AND BOBBIN

- 1 Soak the #8456 VC foam with #5423 40wt shock oil and install it onto the #8456 VC bobbin.

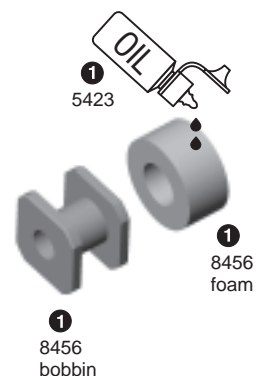
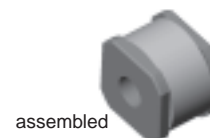

step 3

INTERNAL SHOCK ASSEMBLY

- 1 (Assemble all four shocks at once.) Install the #6469 O-ring over the threads of the shock body.



RACER KIT ONLY: 8458
TEAM KIT ONLY: 8450B
FACTORY TEAM KIT: 3963*

- 2 On the #8844 (3964*) shock shaft, install a #6299 E-clip on both sides of a #6465 (#2) piston from step #1.

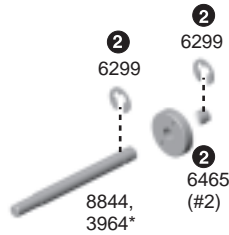

- 3 Slide the VC foam/bobbin assembly over the #8844 (3964*) shaft and then two #5407 O-rings. Place a couple drops of oil on the O-rings.

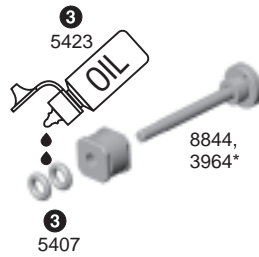

- 4 Insert the assembly into the shock body and pull the shaft through firmly to seat the VC bobbin at the base of the shock bore.
- 5 Push the #7217 pivot ball and eyelet together. As you hold the shaft with a rag and needlenose pliers next to threads, screw the eyelets onto the end of the shock shaft.

TIP: Use a permanent marker to mark your shocks with an F and R to designate front and rear.

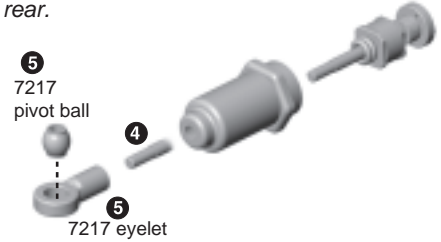

step 4

- 1 Holding the shock upright, fill with oil to the top of the body.

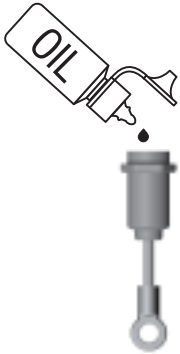

- 2 Slowly move the shaft up and down several times to allow air bubbles to escape to the top.

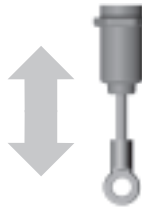

- 3 Refill with oil to the top of the body.

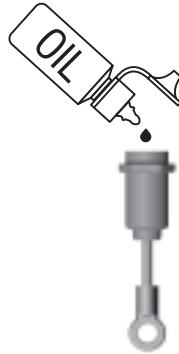

- 4 Push the shaft up until the piston is level with the top of the body. The oil will bulge up above the shock body.



- 5 Fill The #6428 shock cap about halfway with oil and install onto the body. Try to retain as much oil as possible during assembly. The shaft will extend out as you tighten the cap down.

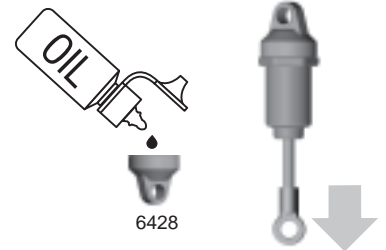

SETTING THE REBOUND

- 6 Move the shock shaft in and out a few times and then push it all the way in. It should be easy to push the shaft in until the eyelet hits the body.

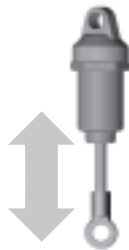

- 7 Then the shaft should push itself out to its full length very slowly.



- 8 If the shock does not push out this far there is not enough oil in it. Add just a little oil and try steps 6-7 again.



- 9 If the shock rebounds too fast, or you cannot push the shaft in until the eyelet hits the body, there is too much oil. Loosen the cap about a full turn and pump out a small amount of oil by pushing the shaft in. Retighten the cap and try steps 6-7 again.
Too much oil in the shock will result in leakage.

BAG G

REMOVE THESE PARTS FOR: Steps 5-8



6925, qty 4
4-40 x 1/2 screw



8846, spring preload spacer
qty 4 ea. 1/8"
qty 2 ea. 1/16"



6472, qty 4
shock nut,
small

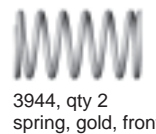

3944, qty 2
spring, gold, front

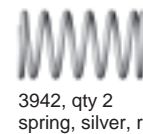

3942, qty 2
spring, silver, rear



6473, qty 4
shock bushing



6475, qty 4
spring collar



6475, qty 4
spring cup



FACTORY TEAM ONLY
3963*, qty 4
collar O-ring



FACTORY TEAM ONLY
3963*, qty 4
shock collar

TOOLS USED

3/32"

step 5

FACTORY TEAM ONLY, STEP 5

- Slide one black O-ring into the groove in the threaded shock collar.



- Use one drop of oil on the O-ring before you thread on the shock collar.



- Thread on the shock collar. Make sure that the shoulder is facing down when threaded on the body.

shoulder faces down



step 6

FINAL SHOCK ASSEMBLY

- Slide the 1/8" #8846 preload spacer onto the body of the two front shocks.
- Slide the 1/8" and 1/16" preload spacers onto the rear shocks.
- Slide on the #6475 spring collar, then #3944 gold spring on the front shocks, and #3942 silver spring on the rear shocks.
- Compress the spring to add the #6475 spring cup.

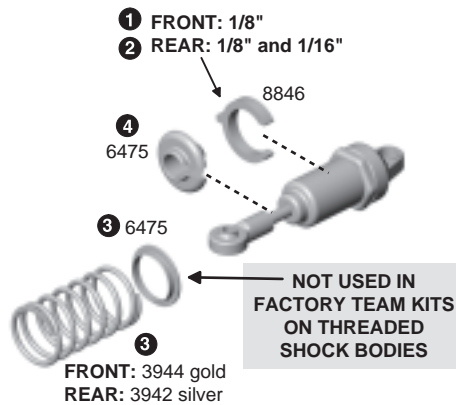

See page 25 to set ride height for your kit.

step 7

FRONT SHOCK MOUNTING

- Add the #6473 shock bushing to the shock tower.
- Push the shock cap over the bushing and add the #6472 nut. **Do not overtighten or the shock will bind.**
- Fasten the lower shock into the arm with the #6925 screw.
- Do the other front shock.

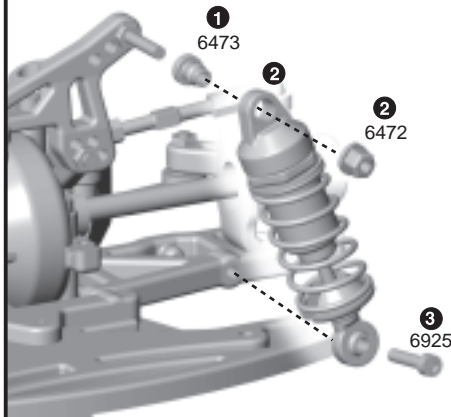

step 8

REAR SHOCK MOUNTING

- Add the #6473 shock bushing to the rear shock tower.
- Push the shock cap over the bushing and add the #6472 nut. **Do not overtighten or the shock will bind.**
- Fasten the lower shock into the arm with the #6925 screw.
- Do the other rear shock.

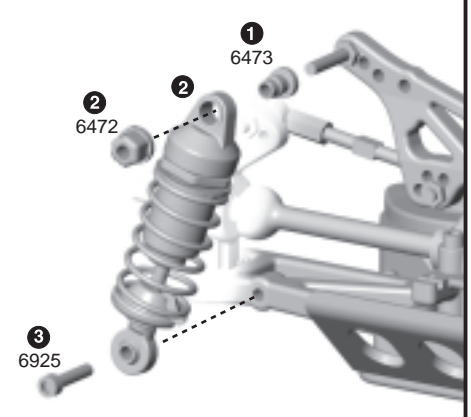

BAG H

REMOVE THESE PARTS FOR: Steps 1-6



3858, qty 1
short special ball end, black



3934, qty 2
3mm motor screw



4449, qty 2
4-40 locknut



RACER & TEAM
6917, qty 4
4-40 x 3/8 screw



6928, qty 1
4-40 x 1 screw



6916, qty 2
4-40 x 1/2 screw with hole



7337, qty 4
steel washer

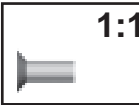

7673, 6934*, qty 2
4-40 x 5/16 screw



6272, qty 4
ball end dust cover



3848, qty 1
foam spacer



3930, 3932*, qty 1
motor cam



3931, 3933*, qty 1
motor clamp (with heatsink)



9180, qty 4
servo horn



7336, offset spacer
qty 2, thin
qty 2, thick

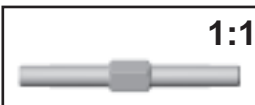

F.T. & TEAM KIT ONLY
1356, qty 1
blue titanium turnbuckle



RACER KIT ONLY
3867, qty 1
steel turnbuckle



6332, qty 3
battery clip



3853, 3974*, qty 1
battery brace

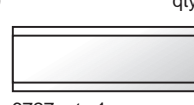

6727, qty 1
servo tape

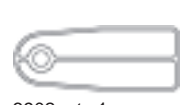

3902, qty 1
transponder mount



3929, qty 1
4-40 x 1.25 screw



3929, qty 1
motor clamp spring

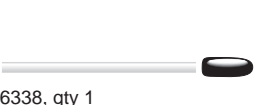

6338, qty 1
antenna tube and cap



7336, qty 2
servo mount

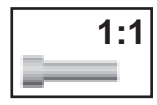

F.T. KIT ONLY
6860*, qty 4
4-40 x 3/8 screw
blue aluminum



F.T. KIT ONLY
3968*, qty 1
counterfeit transponder



F.T. KIT ONLY
3927*, qty 1
clip-on radial heatsink

TOOLS USED

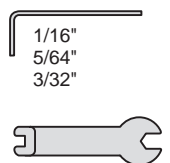

step 1

ADD MOUNTS TO THE SERVO

- Find the appropriate #9180 servo horn for your servo from the chart at right. Install the #3858 ball end into the servo horn. Add the #6272 dust cover. Remove the servo horn from your servo and replace it with the #9180 horn that you selected, then fasten with the stock mounting screw that came with your servo in the position shown below. **DO NOT POINT IT STRAIGHT UP!** See drawing for correct dimension.
- Find the appropriate #7336 offset spacer for your servo from the chart at right. Attach the spacer, if any, in between the #7336 mount and the servo with the #7337 washers and #6917 (6860*) screws.

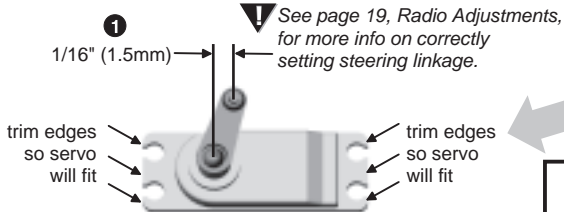
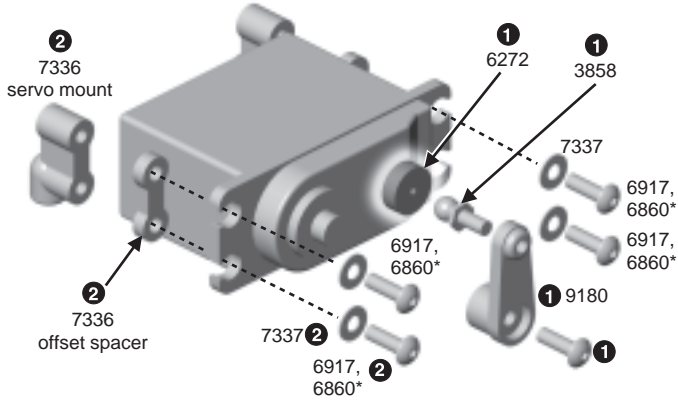

SERVO TYPE	SPACER	SERVO ARM
Airtronics 94102	no spacer	A
Airtronics 94155, 94156, 94157, 94158, 94257, 94258, 94737, 94738, 94741, 94452	thick spacer	A
Futaba ▼ S3003, S9404, S9402, S9303, S3401, S9101, S9202	no spacer	F
Hitec S-300, HS-303, HS-525BB, HS-545BB, HS-422, HS-425, HS-605BB, HS-615MG, HS-925MG, HS-945MG	no spacer	H
JR Z8450, Z8550, NES-4721, NES-4735, Z4750	no spacer	J
JR Z250, Z550, Z2750	thin spacer	J
KO ▼ PS-1012 FET, PS-2000 FET, PS-2001 FET, PS-2004 FET, PS-2015 FET	no spacer	J

▼ On Futaba servo S3003 and on all KO servos you will need to trim a off the sides of the servo ears. We have not tested any servos that were released after mid-1999.

step 2

MOUNT THE SERVO

- Mount the servo to the chassis with two #7673 (6934*) screws.
- Twist #6274 ball cups onto #1356 blue turnbuckle or #3867 steel turnbuckle until you get the dimension shown.
- Use needle-nose pliers to attach the link to the ball ends.

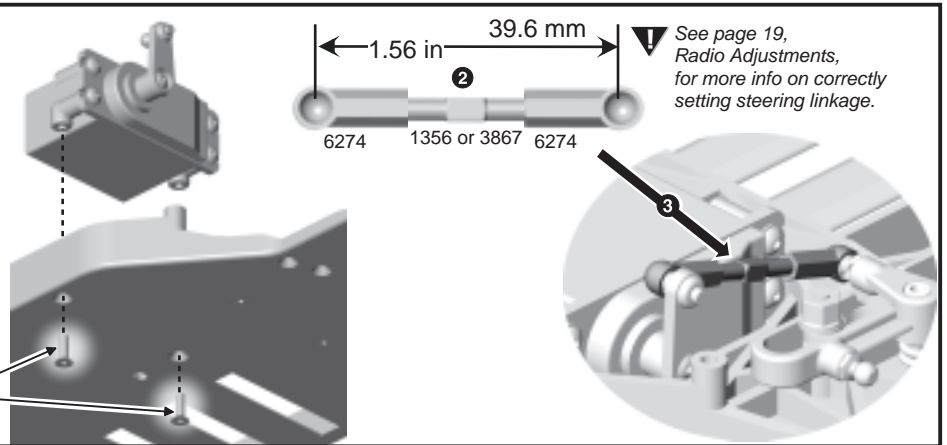

step 3

INSTALL YOUR MOTOR

- Attach the #3930 (3932*) motor cam to the optional motor with two #3934 button head motor screws.
- Install the optional pinion gear of your choice. (Refer to the gearing chart on page 19.)
- Install the two #4449 locknuts to the underside of the chassis. These fit tight, so be sure to put them in straight and all the way in.
- Slide the motor and cam down into the groove of the chassis.
- Screw down the #6928 inner screw first until the #3931 (3932*) motor clamp just touches the chassis bulkhead.
- Set your gear mesh.
- Slide the #3929 spring onto the #3929 screw and thread in only until there is no free play between

the screw and spring. Now tighten the screw 2 to 3 turns. **No more.** It is normal to have an approximately .040"-.050" (1 to 1.2mm) gap remain between the clamp and the bulkhead, as shown.

About .220"-.250" (5.5-6.5mm) when correctly tightened

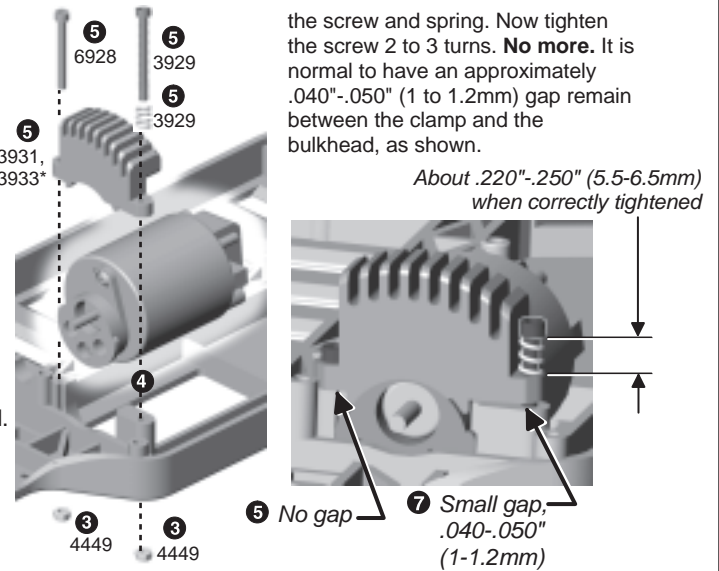

18 ▼ **Motor not included in kit.**
Pinion gear not included in kit.

step 4

FACTORY TEAM KITS ONLY:
Push the #3927* radial heatsink onto the motor.

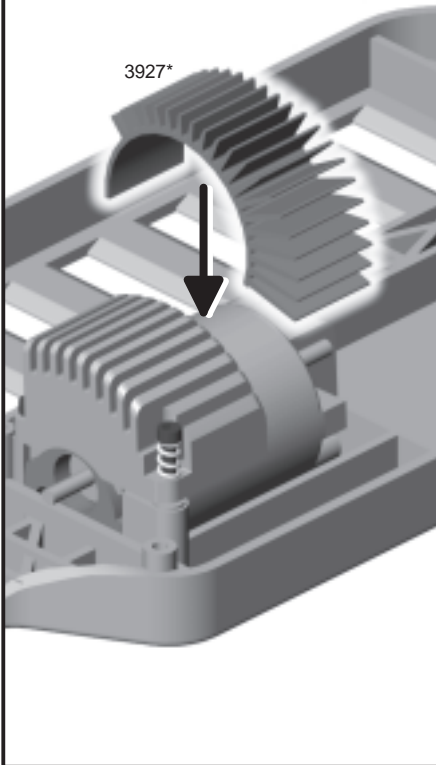

step 5

RADIO AND RECEIVER INSTALLATION

- 1 Cut a piece of #6727 servo tape and use it to attach your optional ESC and switch where shown.
- 2 Cut a piece of #6727 servo tape and use it to attach your optional receiver where shown.
- 3 Connect the ESC and steering servo to your receiver according to your radio or ESC instructions. Then connect the motor to your ESC.
- 4 Push your receiver wire through the built-in antenna mount. Slide the wire through the #6338 antenna and push the antenna firmly into the chassis antenna mount hole. Cap the other end of the antenna tube and wire with the black rubber cap.

TRANSPONDER MOUNT

- 5 If needed, remove the transponder mount and cut away all the areas shown in gray as shown in illustration.
- 6 Attach the mount to the servo where shown with servo tape.
- 7 **FACTORY TEAM KIT ONLY:** Push the #3968* counterfeit transponder peg up through the hole in the mount and slide a #6332 body clip through the small hole on top of the mount.

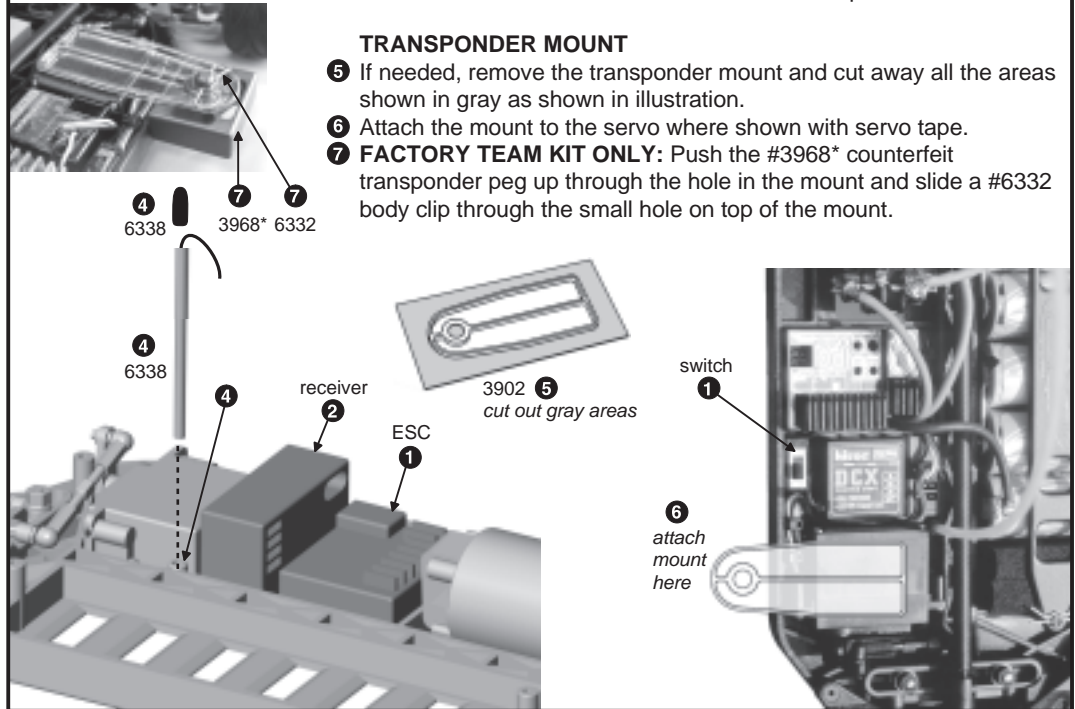

step 6

BATTERY INSTALLATION

- 1 Install your battery pack. See which figure, at left or right, best represents your battery orientation.
- 2 Thread on the two #6916 screws. Aim the body clip hole across the chassis.
- 3 Add the #3848 foam spacer.
- 4 Add the #3853 (3974*) battery hold down strap, orienting it up or down according to your battery pack design. Adjust the screws so the batteries are held tight, but you are still able to push the #6332 body clips through the screws.

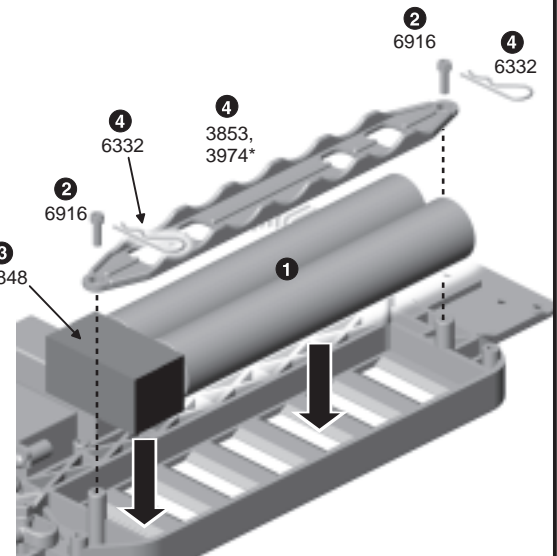
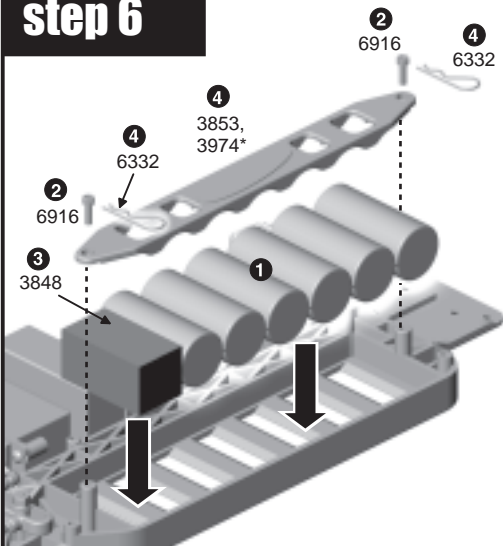

BAG 1

REMOVE THESE PARTS FOR:
Steps 1-2



6332, qty 8
body clip



3852, qty 1
foam bumper



3897, qty 4
pivoting body mount



8874, qty 2
rear body post

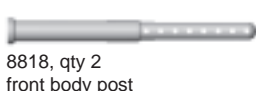

8818, qty 2
front body post

TOOLS USED

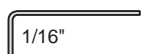

1/16"

step 1

FRONT BODY

1 POSTS

Attach each #8818 front body post to the front bumper with one #6922 screw.

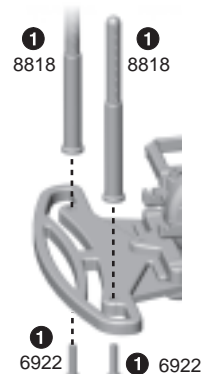

step 2

FOAM BUMPER

- 1 Place the #3852 foam bumper over the front body posts. (You will trim it later to fit your body.)
- 2 Slide the #3897 pivoting body mount over the body post so its holes line up with the fourth hole from the top. (Adjust for proper hole later when you fit your body.)
- 3 Slide the #6332 body clip into the body post and pivoting body mount. (You'll add another body clip after you install your body.)
- 4 Do both front posts.

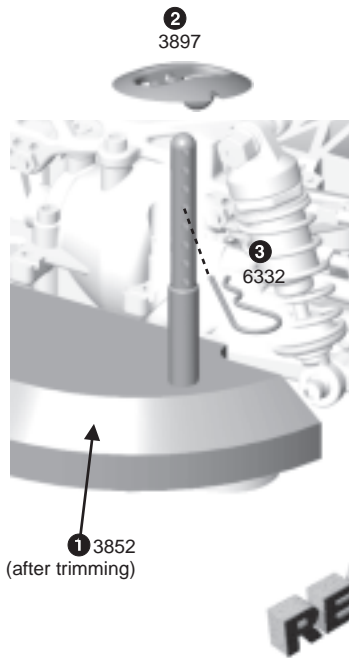

REAR BODY POSTS

- 5 Place the rear #8874 body post to the front side of the rear shock tower. Align the tab and hole and attach it with a #7874 (7873*) screw.
- 6 Slide the #3897 pivoting body mount over the body post so its holes line up with the fifth hole from the top. (Adjust for proper hole later when you fit your body.)
- 7 Slide the #6332 body clip into the body post and pivoting body mount. (You'll add another body clip after you install your body.)
- 8 Repeat on the other rear body post.

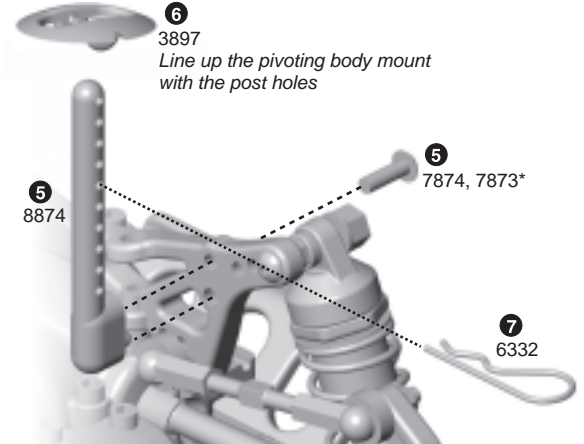

BAG J

REMOVE THESE PARTS FOR:
Steps 1-2

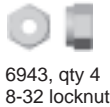

6943, qty 4
8-32 locknut



3950, 3972*, qty 4
wheel hex adaptor



3951, qty 4
TC3 wheel



3955, qty 4
foam wheel insert



3955, qty 4
TC3 tire

TOOLS USED

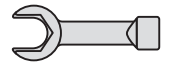

step 1

TIRE ASSEMBLY

- 1 Make a 1/8" hole in the #3951 TC3 wheel.
- 2 Insert the #3955 foam insert into the #3955 tire. Make sure the insert is centered in the tire.
- 3 Install the #3955 tire and insert onto the #3951 wheel.
- 4 Glue the tire to the wheel with super glue (cyanoacrylic glue #1597 Tire Adhesive) in four equally-spaced spots around the tire on both sides. **WARNING!** Follow the adhesive manufacturer's instructions for proper use and safety. Wear eye and hand protection.
TIP: Place a rubber band around the tire to hold it tight to the wheel while gluing.
- 5 Repeat steps for the three remaining tires.

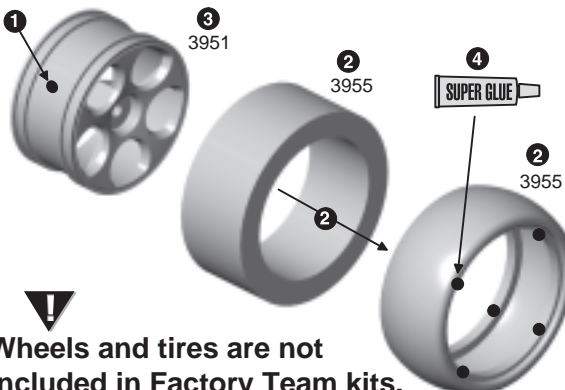

Wheels and tires are not included in Factory Team kits.

step 2

MOUNT TIRES

- 1 Install the #3950 (3972*) wheel hex adaptor to the axle, lining up the roll pin with the slot in the hex adaptor.
- 2 Slide the wheels over the axle and tighten it down with a #6943 lock nut.
- 3 Install the remaining tires.

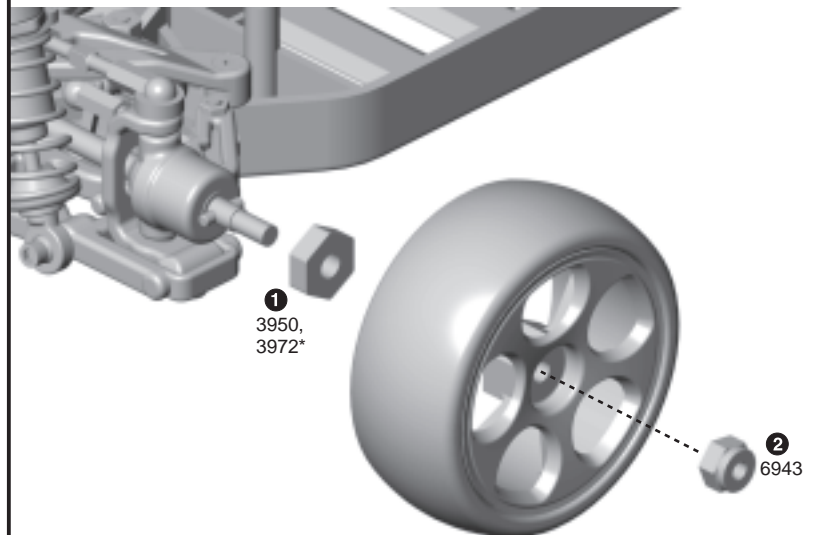

BAG K

FACTORY TEAM KIT ONLY

TOOLS USED

REMOVE THESE PARTS FOR: Steps 1-4



8828*, qty 4 open cup



8828*, qty 4 closed cup



8828*, qty 4 5/16" set screw



3960*, qty 2 anti-roll bar



8830*, qty 4 pivot



6951*, qty 4 set screw



9146*, qty 4 screw



WHAT ARE ANTI-ROLL BARS?

Anti-roll bars (also known as sway bars) are used to stabilize a car from excessive chassis roll (which occurs when your car leans outward through the turns by centrifugal force). Anti-roll bars are generally used on smooth, high traction track conditions. If the conditions are very bumpy, then anti-roll bars are probably not necessary.

WHEN ARE ANTI-ROLL BARS NEEDED?

If you are driving on a high traction surface and your car wants to oversteer, then use the bar on the front only. This will decrease the front chassis roll and decrease steering through the corner. This has the feeling of increasing rear traction.

If your car is understeering, then try the anti-roll bar kit on the rear only. The rear anti-roll bar will decrease rear traction. This has the feeling of increasing steering.

step 1

ROLL BAR LINKS

- 1 Thread one #8828 open cup and one closed cup onto each 5/16" set screw to the dimension shown at right.

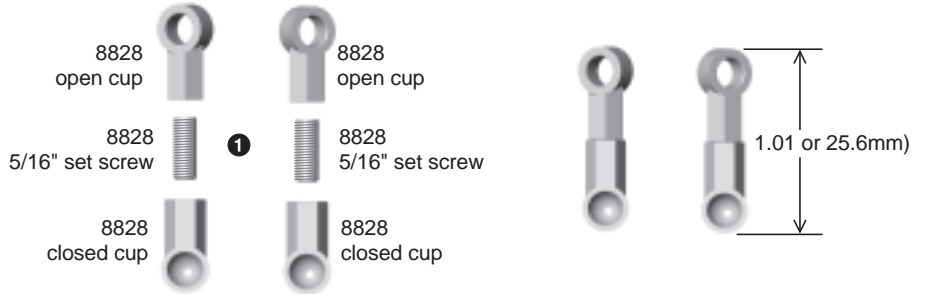

step 2

ADD PIVOTS

- 1 Place the aluminum #8830 anti-roll bar pivots over the ends of the anti-roll bar according to the dimension shown, and tighten down with the #6951 set screw.



Bar shown right side up

step 3

- 1 Place the anti-roll bar into the grooves of the lower transmission case and secure using two #9146 2-56 x 3/16" screws. Do not overtighten; the roll bar should move up and down freely.

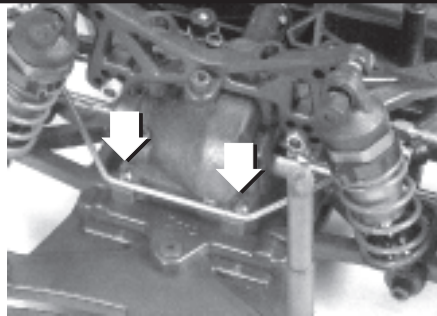

Front

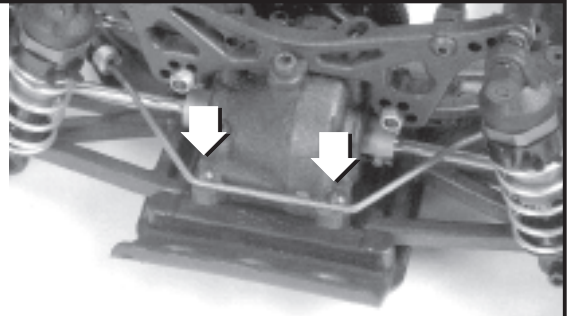

Rear

step 4

- 1 Attach the open cup side of the linkages to the antiroll bar.
- 2 Make sure your car is ready to run without the body installed.
- 3 Drop your car from about 2" high onto a flat surface.
- 4 Without moving the suspension, adjust the link so it aligns with the balls exactly, then snap it onto the balls with your needle nose pliers. This ensures that the anti-roll bar is not under tension when your vehicle is at ride height.

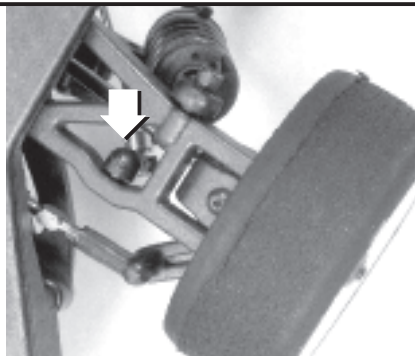

Front

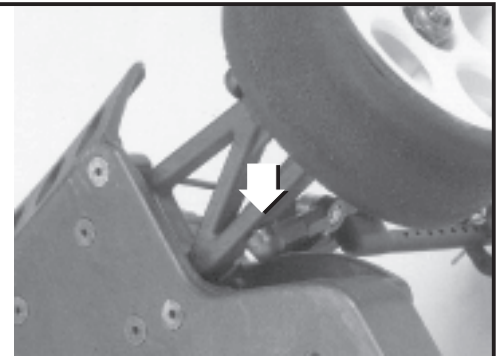

Rear

FINAL ADJUSTMENTS

Make these adjustments before racing

FINISHING THE BODY

Before you start to mask and paint the inside of your TC3's body, wash it out with soap and water to remove any mold release residue or dirt that may show up in your paint.

1. Mark the body post holes and rear wheel cutout

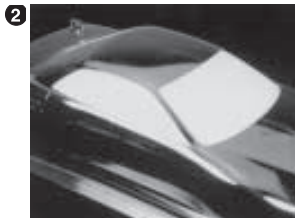

with a marker on the outside of the body.

2. Each body comes with pre-cut self-adhesive window masks for your convenience.

3. Be sure to use a paint that is specifically formulated to adhere to Lexan. Spray several thin coats (instead of one thick coat) to avoid runs. If possible,

spray your darker colors first.

4. After painting, trim the wheel wells with curved scissors or a sharp hobby knife.

5. Trim out the rear wing and mount it to the body with the supplied 4-40 button head screws and nylon nuts.

6. Finish by applying decals.

RADIO ADJUSTMENTS

Use the following steps to make the final adjustments on your car.

1. Turn the transmitter on.

2. Make sure the motor is disconnected.

3. Connect your battery pack.

4. Turn the power switch on.

5. Move the steering control on the transmitter to the right and left. Do the wheels move in the correct direction? If not, you must reverse the steering servo direction on your transmitter (see radio manual.)

6. Look at the servo horn mounted on the servo. It should lean toward the centerline of the chassis about 1/8" (3mm).

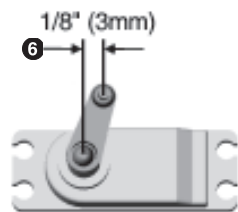

7. Adjust the servo turnbuckle so that the steering rack arm is EXACTLY in the center of the car.

8. Using the two steering turnbuckles, adjust the front wheels so they are pointed straight ahead.

9. Adjust the ESC (electronic speed control) according to the speed control manufacturer's instructions.

Note: Some manufacturers have the motor connected during adjustment and some do not. Now turn the power switch off.

10. Connect the motor. Place your car on a block or car stand so that all four wheels cannot touch anything. Turn the power switch on again. Check the ESC and steering settings you have made and then turn the power switch back off.

10. Remember this! The transmitter is always the **FIRST TO BE TURNED ON** and **THE LAST TURNED OFF**.

CONGRATULATIONS! YOUR CAR IS NOW READY TO RUN!

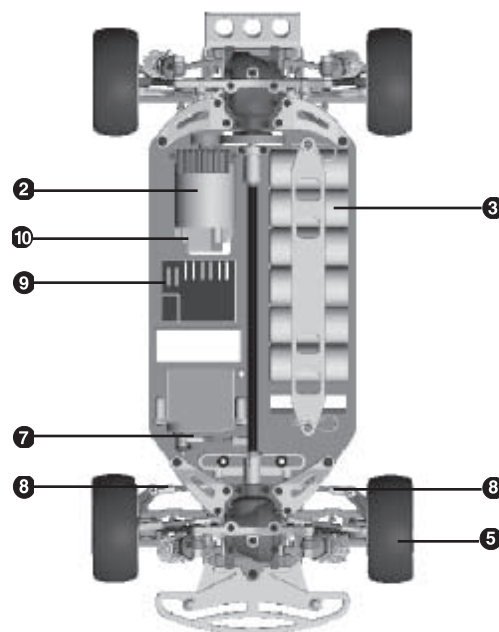

MOTOR GEARING

To get the most from your motor, proper gearing is important. The gear ratios listed in the chart are recommended starting gear ratios. Ratios can vary from track to track, but you should not change the pinion size more than one tooth from the recommended ratio.

CAUTION! Increasing the pinion size by more than one tooth can damage your motor from excess heat.

MOTOR	PINION	SPUR	FINAL DRIVE RATIO	OVERALL RATIO
24° ROAR stock motor	28	72	2.5:1	6.43
36° stock motor	26	72	2.5:1	6.92
16 turn modified motor	26	72	2.5:1	6.92
15 turn modified motor	25	72	2.5:1	7.2
14 turn modified motor	24	72	2.5:1	7.5
13 turn modified motor	23	72	2.5:1	7.83
12 turn modified motor	22	72	2.5:1	8.18
11 turn modified motor	21	72	2.5:1	8.57
10 turn modified motor	20	72	2.5:1	9.00
9 turn modified motor	19	72	2.5:1	9.47

MAINTENANCE

Follow these steps to keep your car in shape for racing

CHECK FOR FIT

You should periodically check all the moving parts: front and rear end, suspension arms, steering blocks, steering linkage, shocks, and so on. If any of these should get dirty or bind then your car's performance will suffer.

MOTOR MAINTENANCE

Between runs, inspect the brushes to ensure they are moving freely in the brush holder. This is done by

carefully removing the spring and sliding the brush in and out of the holder. If there is any resistance or rough spots, remove the brush and carefully wipe the brush clean. This will clean off any buildup and lubricate the brush so it slides smoothly in the brush holder.

After every 3 to 5 runs, remove the brushes from the holders and inspect the tips for wear and/or burning. If there is a noticeable amount of wear, replace the brush with a new pair. If the tip is a burnt blue color, then the lubricant in the brush has been burned away and new brushes should be installed.

After every other battery charge you should carefully clean the motor. One recommended method is to spray motor cleaner directly on the brush and commutator area. Run the motor for approximately 15 seconds. Disconnect the motor and spray it again, making sure the runoff is clear and clean. If the runoff is still dirty, repeat the spraying action until clean. After completing the cleaning, apply a small amount of lightweight oil to each bushing or bearing for lubrication. Be careful not to apply too much oil, for this will pick up dirt and contaminate the commutator and brushes.

DIFFERENTIAL MAINTENANCE

You should rebuild the differentials when the action gets somewhat "gritty" feeling. Usually cleaning the diff parts and applying new lube per the instructions will bring it back to new condition again. The standard 3/32" carbide balls rarely need replacing. Normally, as the parts seat, the diff will get smoother.

If the diff still feels gritty after carefully cleaning and re-lubing the diff parts, the thrust balls, thrust washers, and drive rings should be checked and possibly replaced.

The parts will normally wear out in the following order:

1. #6575 5/64" diff thrust balls (qty 6).
2. #6573 diff thrust washers (2).
3. #3906 D-drive rings (2).

Refer to the differential section to correctly assemble the diff.

TUNING & SETUP TIPS

Your car is one of the most tunable on road cars on the market. This section will try to explain the parts and adjustments you can use to tune your car for different track conditions.

CASTER describes the angle of the kingpin from vertical when looked at from the side of the car. Positive caster means the kingpin leans rearward at the top. Negative caster should never be used.

These tips prepare your car for maximum performance

Positive caster means the kingpin leans rearward at the top.

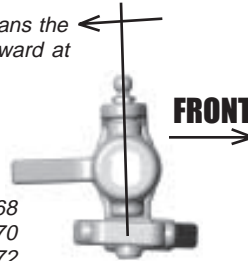

- 0° block carrier, #3868
- 2° block carrier, #3870
- 4° block carrier, #3872

Associated makes block carriers for the TC3 with 0° (kit standard), 2°, and 4° of caster. Increasing caster in the TC3 (with 2° or 4° block carriers) will give your car more steering entering corners but less steering exiting corners. It will also be more stable in bumpy conditions.

Note: When figuring total caster in your car, add the amount in the block carrier to the amount of kickup. Example: 2° of kickup (kit standard) and 0° block carrier equals total of 2° of caster.

KICKUP refers to the angle at which the front suspension is mounted in relation to horizontal when looked from the side of the car. Kickup is adjusted by changing the suspension arm mounts, which have molded codes to help you tell them apart. The two front arm mount combinations are as follows:

RECOMMENDED ARM MOUNT/BLOCK CARRIER COMBINATIONS

FOR THIS SETUP:	USE THESE PARTS:		
	Arm Mounts		Block Carrier
	A	B	C
2° kickup, 2° caster	F	F+2	0°
2° kickup, 4° caster	F	F+2	2°
0° kickup, 0° caster	F	F-0	0°
0° kickup, 2° caster	F	F-0	2°
0° kickup, 4° caster	F	F-0	4°

EFFECTS OF ARM MOUNT/BLOCK CARRIER COMBINATIONS

The kit setting of 2° kickup will work best in most conditions, especially in bumpy conditions.

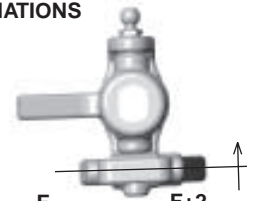

0° kickup will have a more aggressive steering feeling but will not absorb bumps as well as 2°.

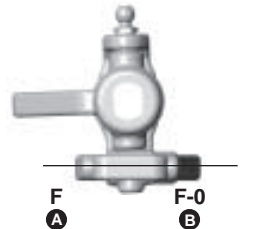

A B ARM MOUNT PART NUMBERS

code	effect	part #
F		#3863 (std)
F+2	+2° kickup	#3863 (std)
F-0	0° kickup	#3864 (optional)

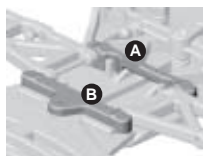

C BLOCK CARRIER PART NUMBERS

effect	part #
0° caster	#3868 (std)
2° caster	#3870 (optional)
4° caster	#3872 (optional)



FRONT TOE-IN AND TOE-OUT is adjusted by turning the steering turnbuckles. Toe-in will make your car easier to drive by improving stability during acceleration. Toe-out will increase steering when entering corners but will be slightly more difficult to drive. We suggest using 0° to 1° toe-out on the TC3.



Toe-in:
Easier to drive.
Improves stability during acceleration.



Toe-out:
Harder to drive.
Increases steering entering corners.

REAR ANTI-SQUAT describes the angle at which the rear suspension is mounted in relation to horizontal when looked at from the side of the car. The TC3 comes standard with 2° of rear anti-squat. This provides good rear traction. Installing the #3864 (R3+0) rear arm mount reduces anti-squat to 0° and will reduce rear traction. However, it will improve acceleration in bumpy conditions and increase steering slightly.

REAR ARM MOUNT INFORMATION		
code	effect	part #
R		#3863 (std)
R+3+2	3° toe-in & 2° anti-squat	#3863 (std)
R+3+0	3° toe-in & 0° anti-squat	#3864 (optional)
R+2+0	2° toe-in & 0° anti-squat	#3864 (optional)
R+2+2	2° toe-in & 2° anti-squat	#3864 (optional)

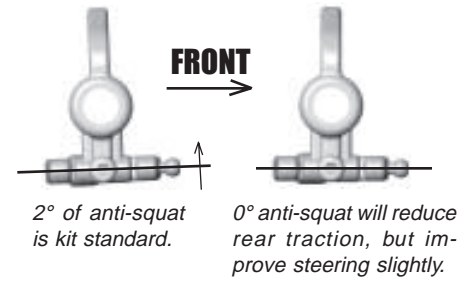

REAR TOE-IN is adjusted by changing the rear arm mounts. The TC3 comes standard with 3° of toe-in on each side. This setting should work best in any condition. However, if less toe-in is desired, install the #3864 (R+2+2) or #3864 (R+2+0) rear arm mounts. These mounts have 2° of toe-in and will decrease rear traction and add steering. (See rear anti-squat details above for more info on the mounts.)

WHEELBASE ADJUSTMENT can be made to the TC3 by moving the two #4187 1/32" plastic spacers on the outer rear hinge pins (next to the hub carrier).

Moving the spacers to the front of the hub carrier will lengthen the wheelbase and decrease rear traction.

Moving the spacers to the rear of the hub carrier will shorten the wheelbase and increase rear traction.

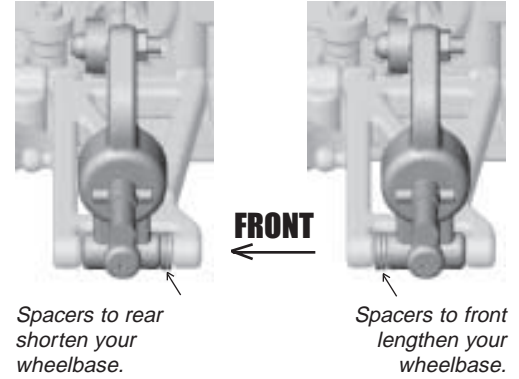

RIDE HEIGHT describes the height of the chassis in relation to the surface it is sitting on. This adjustment must be made with the chassis ready-to-run but with no body. The #8846 shock preload spacers are used for raising and lowering the ride height.

We suggest starting with about 1/4" (6.0mm) clearance between the chassis and ground. Try using a slightly lower ride height for high traction conditions such as carpet racing. Do not use a ride height lower than 5/32" (4mm).

For more tips on setting ride height, see next page.

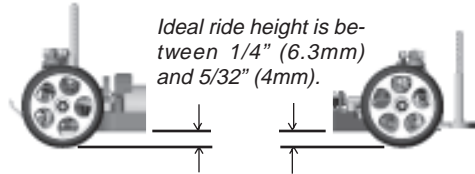

Adjust preload spacers to change your ride height.

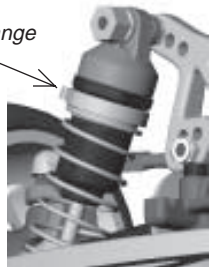

CAMBER LINK LOCATIONS on the TC3 have been thoroughly tested to find the best all around positions. We suggest using the standard setting for all conditions. However, if you must make adjustments, the following guidelines should help you: The longer or higher the link, the more traction and less stability. The shorter or lower the link, the less traction and greater stability.

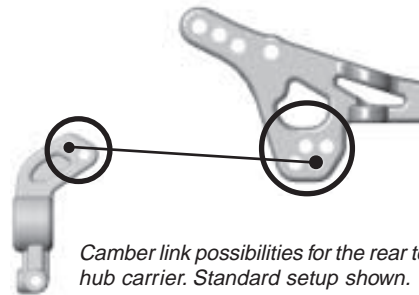

ACKERMAN is a term describing the effect of the inside front wheel turning tighter than the outside front wheel. The standard setup works best in most conditions and is preferred by most of our Team drivers.

By adding two .100" (2.5mm) spacers and the longer #3858 ball ends to the steering rack, a more aggressive steering feeling can be achieved. This is because there will be less ackerman.

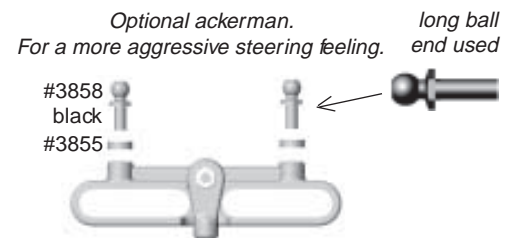
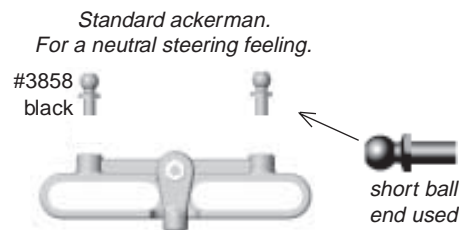

CAMBER describes the angle the wheels ride relative to the ground when looked at from the front or back. Negative camber means that the tire leans inward at the top. Positive camber means just the opposite, and should not be used.



Negative camber means that the tire leans inward at the top. Change camber by turning the camber link.

We suggest using 2° of negative camber to start with. For tips on setting camber, see next page.

SETTING CAMBER

Setting camber is one of the tuning options that the TC3 offers. To set the camber we recommend using a camber gauge, 3x5" card or just a square piece of cardboard. When adjusting camber you need to have the car ready to run with no body.

1. Set the car on a flat surface.
2. Take your 3x5 card and push it against the tire as shown in fig. 1.
3. Use your supplied molded turnbuckle wrench to adjust the camber link to 1°, 2° or 3° by either eyeball the gap between the card and the top of the tire (fig. 2), or place a ruler across the top of the tires and measure from the card to the tire.

(If you really want to know exact figures, 1° produces a .045" (1.1mm) gap, 2° produces a .088" (2.2mm) gap, and 3° produces a .130" (3.3mm) gap. But it's hard to measure!)

We recommend using 2° of negative camber. On high traction tracks 2° to 3° negative camber would be used, 1° to 2° would be used in low traction conditions. We don't recommend using positive camber under any circumstances.

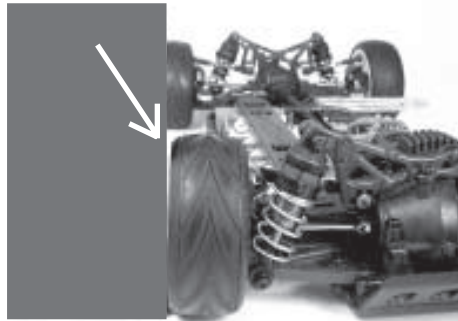

Fig. 1

Push a 3x5 card against the tire. Arrow is pointing to the negative camber gap at the top.

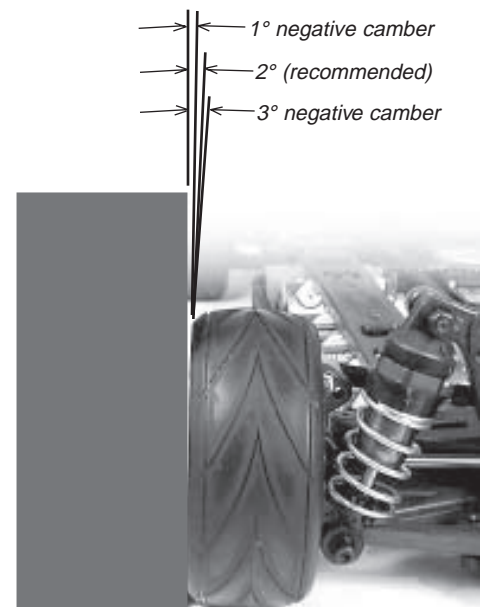

Fig. 2

Eyeball or measure the gap for camber. We recommend 2° negative camber to start with.

SETTING RIDE HEIGHT

Setting the ride height is another adjustment of the TC3. The ride height is easily adjusted by the #8846 shock preload spacers, shown in fig. 1, used for the non-threaded shocks. The suggested preload for the TC3 is one 1/8" preload for the front shocks and one 1/8" and one 1/16" spacers for the rear shocks. (See page 17, step 6 for more about the preload spacers.) These preload spacers set the ride height at 1/4" (6.0mm).

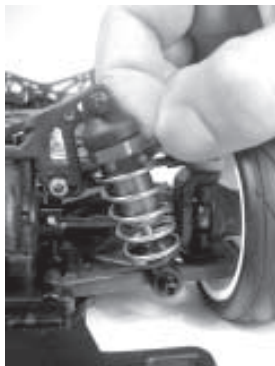

Fig. 1

Shock pre-load spacer inserted on non-threaded shock.

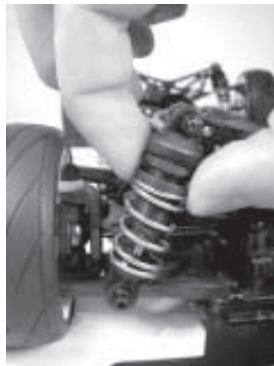

Fig. 2A

Adjusting collar on threaded shock.

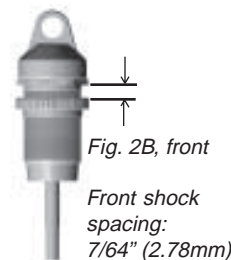

Fig. 2B, front

Front shock spacing: 7/64" (2.78mm)

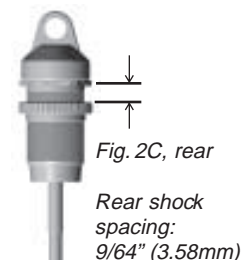

Fig. 2C, rear

Rear shock spacing: 9/64" (3.58mm)

the car ready to run with no body.

2. Set the car on a flat surface.

3. Slide the ride height gauge underneath the chassis, as shown in fig. 4A, until the gauge just touches the chassis. To get a measurement on the chassis and not the bumper, you might need to slide the gauge in the corner of the car as shown in fig. 4A. Check both corners of the front.

4. Slide the gauge underneath the back of the car. Check both corners of the rear (fig. 4B).



Fig. 3

Measure your ride height quickly and easily with Associated's Ride Height Gauge #1450 (not included in kits).



Fig. 4A, front

Slide your Ride Height Gauge under the chassis so you don't measure the bumper.

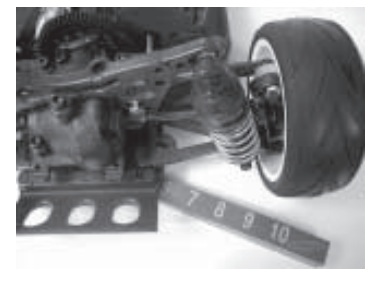

Fig. 4B, rear

Slide your Ride Height Gauge under the chassis so you don't measure the bumper.

SHOCKTRAVEL can be adjusted on the TC3 to help speed up or slow down how fast the car changes direction when cornering. The TC3 standard setup is setting 6 on your droop gauge in the front and 4 on the rear. This setup will work best in almost any condition.

If your track is bumpy, you may want to add droop to your car by going to a lower droop gauge step.

If your track has very high traction, such as occurs with carpet, then you may want to take droop out of your car by going higher on the droop gauge. Too little droop will cause a loss of traction.

higher traction
less droop



droop gauge

more bumps
more droop



BATTERY PLACEMENT in the TC3 allows you to slide your batteries forward or back to change the handling characteristics of your car. There are many combinations, but here are three we suggest trying.

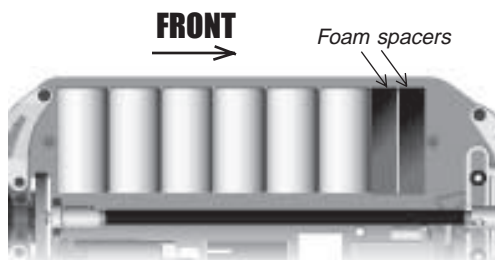

Batteries to rear:
More traction.
Less steering.

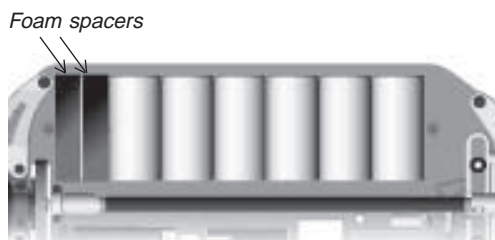

Batteries to front:
Less traction.
More steering.

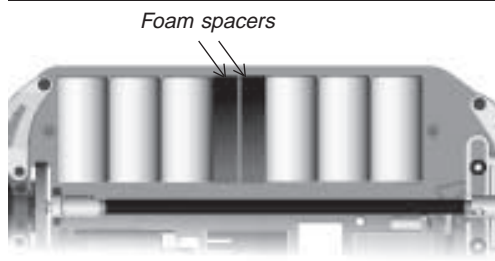

Batteries separated:
Slightly more steering than full rear.
Slightly less rear traction than full front.
Easy to drive.

SHOCK SPRINGS try to keep your car level during acceleration, deceleration, and cornering.

Stiffer springs will help your suspension respond more quickly, but because of their stiffness will not absorb bumps as well. Use stiffer springs in high traction conditions such as carpet racing.

Softer springs are best for slippery or bumpy conditions.

#3941	Green	12 lbs/in	softer
#3942	Silver	14.5 lbs/in (std rear)	↑
#3943	Blue	17 lbs/in	
#3944	Gold	19.5 lbs/in (std front)	↓
#3945	Red	22 lbs/in	
#3946	Copper	25 lbs/in	↑
#3952	Purple	30 lbs/in	
#3953	Yellow	35 lbs/in	
#3954	White	40 lbs/in	

ANTI-ROLL BARS are used to stabilize a car from excessive chassis roll (which occurs when your car leans through the turns by centrifugal force). Anti-roll bars are generally used on smooth, high traction track conditions. If the conditions are very bumpy, then anti-roll bars are probably not necessary.

If you are driving on a high traction surface and your car wants to oversteer, then use the optional #3960 anti-roll bar kit on the front only. This will decrease the front chassis roll and decrease steering throughout the corner. This has the feeling of increasing rear traction.

If your car is understeering, then try the optional #3960 anti-roll bar kit on the rear only. The rear anti-roll bar will decrease rear chassis roll and decrease rear traction (this has the feeling of increasing steering).



Antiroll bar (sway bar) kit #3960.

TIRES & INSERTS are two of the most influential changes you can make to your car. The TC3 comes standard with Pro-Line S-2 compound V-Rage tires. This is a good traction, long-wearing tire for all around use.

If you would like more traction, try the Pro-Line #1091 S-3 compound tires with Pro-Line tire inserts. For racing conditions, try the Pro-Line #1089S2 S-2 slicks or #1089S3 S-3 racing slicks. These optional tires are available from Pro-Line.

STANDARD SETTINGS of the TC3 are presented below.

1. Front camber: -2°.
2. Front camber link: inside lower hole on tower.
3. Front block carrier: 0°.
4. Front toe: 0° to 1° toe-out.
5. Front ride height: 1/4" (6.3mm).
6. Kickup: +2°.
7. Bump steer spacers: none.
8. Ackerman: #3858 ball ends, no spacers.
9. Front anti-roll bar: none.
10. Rear camber: 1° to 2° negative.
11. Rear camber link: tower: inside lower hole. Hub carrier: outside hole.
12. Rear toe-in: 3°.
13. Rear ride height: 1/4" (6.3mm).
14. Rear Anti-squat: 2°.
15. Rear anti-roll bar: none.
16. Driveshafts: MIP CVD's.
17. Wheelbase: hub carriers centered.
18. Shock body: macro shock.
19. Shock oil: front, 40wt. Rear, 40wt.
20. Shock shaft: front, #8844. Rear, #8844.
21. Shock pistons: front, #2. Rear, #2.
22. Shock springs: front, Gold. Rear, Silver.
23. Shock limiters: front, 4. Rear, 2.
24. Shock mounting, front tower, outside hole.
25. Shock mounting, rear tower, outside hole.
26. Batteries: 6-cell.
27. Battery placement: rear.
28. Motor: varies.
29. Speed control: varies.
30. Radio: varies.
31. One way, front diff: none.
32. Tires, front: Pro-Line V-Rage S-2 compound.
33. Tires, rear: Pro-Line V-Rage S-2 compound.
34. Tire additive: none.
35. Inserts: incl. with tires.
36. Wheels: Pro-Line.
37. Spur gear: 72 (from Kimbrough)
38. Pinion gear: varies.
39. Lead weights: none.
40. Chassis: Composite.
41. Body: varies.
42. Wing: varies with body.

SETUP SHEET for the TC3 is included. Set up your TC3 with the standard settings at right, then deviate from them in response to your track conditions and driving style, as noted below.

Tips for beginners:

For best results, make only one setup change at a time, testing it before making another change. Make a copy of the setup sheet included in this manual to help keep track of your changes.

Before you make any changes to the standard settings, make sure you can get around the track without crashing. None of your setup changes will work if you cannot stay on the track.

Your goal is consistent lap times. Inconsistent lap times may indicate poor control. When you have consistent lap times, then make changes to your car.

If the change results in a faster lap, then mark the change in your setup sheet. If performance is worse, then revert back to the previous setup and try another change.

Fill out your setup sheet thoroughly when you are satisfied with it and file it away. It can be a practical guide for future track layouts and conditions you encounter.

BUMPY TRACK SETTING**Front Suspension:**

1. Block carriers: 0°
2. Kickup: 2°
3. Toe-in: 0°
4. Toe-out: 0°
5. Camber: -1.5°
6. Ride height: 6mm
7. Anti-roll bar: none
8. Ackerman setting: std
9. Shock bodies: VCS
10. Shock piston: #2
11. Shock oil: 30wt
12. Spring: silver
13. Droop setting: 5
14. Camber link position: std
15. Shock mounting: middle hole

Rear Suspension:

1. Toe-in: 2°
2. Anti-squat: 2°
3. Camber: -1.5°
4. Wheelbase: middle
5. Ride height: 6mm
6. Anti-roll bar: none
7. Shock bodies: VCS
8. Shock piston: #2
9. Shock oil: 25wt
10. Spring: green
11. Droop setting: 3
12. Camber link position:
 - Tower: std
 - Hub: std
13. Shock mounting: middle hole

General:

1. Battery position: rear
2. One-way or Diff: diff
3. Drive shafts: alum CVD's
4. Body: varies
5. Spur: 72

CARPET WITH FOAM TIRES**Front Suspension:**

1. Block carriers: 4°
2. Kickup: 2°
3. Toe-in: 0°
4. Toe-out: 0°
5. Camber: -1.5°
6. Ride height: 4mm
7. Anti-roll bar: std
8. Ackerman setting: std
9. Shock bodies: VCS
10. Shock piston: #2
11. Shock oil: 70wt
12. Spring: white
13. Droop setting: 6
14. Camber link position: std
15. Shock mounting: middle hole
16. Tires: Jaco orange purple

Rear Suspension:

1. Toe-in: 3°
2. Anti-squat: °
3. Camber: -2°
4. Wheelbase: middle
5. Ride height: 4mm
6. Anti-roll bar: std
7. Shock bodies: VCS
8. Shock piston: #2
9. Shock oil: 50wt
10. Spring: red
11. Droop setting: 4
12. Camber link position:
 - Tower: upper inner hole
 - Hub: std
13. Shock mounting- middle hole
14. Tires: Jaco purple

General:

1. Battery position: rear
2. One-way or Diff: diff
3. Drive shafts: alum CVD's
4. Body: varies
5. Spur: 72

**ONE-WAY FRONT DIFF
(Worlds 2000)****Front Suspension:**

1. Block carriers: 4°
2. Kickup: 2°
3. Toe-in: 0°
4. Toe-out: 0°
5. Camber: -2°
6. Ride height: 4.5mm
7. Anti-roll bar: std
8. Ackerman setting: std
9. Shock bodies: VCS
10. Shock piston: #2
11. Shock oil: 40wt
12. Spring: gold
13. Droop setting: 5.5
14. Camber link position: upper inner hole
15. Shock mounting: inner hole

Rear Suspension:

1. Toe-in: 3°
2. Anti-squat: 0°
3. Camber: -2°
4. Wheelbase: middle
5. Ride height: 4.5mm
6. Anti-roll bar: std
7. Shock bodies: VCS
8. Shock piston: #2
9. Shock oil: 30wt
10. Spring: silver
11. Droop setting: 4
12. Camber link position:
 - Tower: upper inner hole
 - Hub: std
13. Shock mounting: inner hole

General:

1. Battery position: rear
2. One-way or Diff: one-way
3. Drive shafts: alum CVD's
4. Body: varies



TC3

SETUP SHEET Team Associated
RC10TC3 4WD Touring Car

Driver: _____

Track/City: _____

Event: _____ Date: _____

FRONT SUSPENSION

CASTER 0° 2° 4° ANTI-ROLL BAR: None Size: _____

KICKUP 0° 2° -2°

TOE-IN _____° TOE-OUT _____°

CAMBER _____°

RIDE HEIGHT



BUMP
STEER



ACKERMAN SETTING

Std Other: _____

Ball end: _____

Spacer: _____



FRONT SHOCKS

BODY Composite Alum.

SHAFT Std Other: _____

LIMITERS:

Inside: _____

Outside: _____

DROOP GAUGE #: _____

PISTON # _____

OIL _____ WT

SPRING _____

SHOCK MOUNT &
CAMBER LINK
Fill in holes used



REAR SUSPENSION

ANTI-SQUAT 0° 2°

ANTI-ROLL BAR: None Size: _____

TOE-IN 3° Other: _____

CAMBER: _____°

RIDE HEIGHT

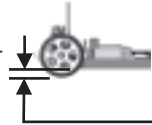

WHEELBASE
ADJUSTMENT

← FRONT

Short



Medium



Long



REAR SHOCKS

BODY Composite Alum.

SHAFT Std Other: _____

LIMITERS:

Inside: _____

Outside: _____

DROOP GAUGE #: _____

PISTON # _____

OIL _____ WT

SPRING _____

SHOCK MOUNT &
CAMBER LINK
Fill in holes used



OTHER

FRONT TIRES: _____ Compound: _____ Insert: _____ Wheel: _____

REAR TIRES: _____ Compound: _____ Insert: _____ Wheel: _____

BATTERY PLACEMENT Back Front Other: _____ BATTERY TYPE: _____

CHASSIS Std Carbon Fiber FRONT/REAR DRIVE Std One-way SPUR/PINION _____ T / _____ T

MOTOR _____ BRUSH _____ SPRING _____

RADIO _____ SERVO _____ ESC _____

BODY _____ WING _____

TIRE ADDITIVE _____ LEAD WEIGHTS _____ (oz/gm) Indicate location:
 None None

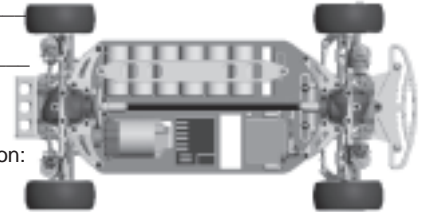

TRACK CONDITIONS

SURFACE: Smooth Bumpy

TRACTION: Low Med. High

COMPOSITION:

Concrete Asphalt Carpet Other: _____

NOTES: _____

RACE COMMENTS

MAIN _____ FINISH _____ QUALIFYING. POS. _____

NOTES: _____

CAR COMMENTS

NOTES: _____
