



INSTRUCTION MANUAL FOR THE RC10T3

for kits:

#7003

#7009

#7010

#7013

#7038

#7048

Copyright 2000-2001 Associated Electrics, Inc.



Pro-Line Chevy body in Team and Factory Team kits shown.

RC10T3

All kit versions include:

- 2.40:1 Stealth transmission for effortless power handling.
- Lexan T3 racing body.
- Quadra-symmetric suspension for greater stability and handling.
- Optimized front end geometry improves steering and increases rigidity.
- Adjustable battery placement for fine tuning of traction or steering.
- 2.2" one-piece front and rear wheels.
- Pro-Line Edge M2 front tires and Pro-Line "Bowtie" M2 rear tires.

FACTORY TEAM

Shocks: Hard anodized, Teflon-coated gray.
Rear Axles: MIP CVD's.
Sealed ball bearings.

Also includes:
Factory Team parts, graphite chassis.

TEAM KIT

Shocks: Hard anodized, Teflon-coated gray.
Rear Axles: MIP CVD's.

Also includes:
Sealed ball bearings.

SPORT KIT

Shocks: Gold shocks.
Rear Axles: Associated dogbones & stub axles.
Bushings throughout.

Also includes:
Mechanical speed control and motor.

BASIC+ KIT

Shocks: Gold shocks.
Rear Axles: Associated dogbones & stub axles.

Also includes:
Bushings throughout and motor.

RTR

Shocks: Oil-filled shocks.
Rear Axles: Associated dogbones & stub axles.
Painted truck body.
Stealth Transmission.

Also includes:
Bushings throughout, quality AM radio, LRP Runner speed control, 20 turn motor, glued tires.

ARR

Shocks: Oil-filled shocks.
Rear Axles: Associated dogbones & stub axles.
Painted truck body.
Stealth transmission.

Also includes:
Bushings throughout, glued tires.

REQUIRED EQUIPMENT TO RUN YOUR KIT

BUSHING KITS

for the T3 Sport kit #7013

R/C two channel surface frequency radio system with two servos.
Battery pack (6 cell).
Battery charger (we recommend a peak detection charger).
8 AA batteries.

for the T3 Basic+ kit #7003

R/C two channel surface frequency radio system with one servo.
Battery pack (6 cell).
Battery charger (we recommend a peak detection charger).
Electronic speed control.
Pinion gear, 48 ptich. Teeth to be determined by type and wind of motor.

FACTORY ASSEMBLED BUSHING TRUCKS

for the T3 ARR truck #7009

R/C two channel surface frequency radio system with one servo.
Battery pack (6 cell).
Battery charger (we recommend a peak detection charger).
Electronic speed control.
8 AA batteries.

for the T3 RTR TRUCK #7010

Battery pack (6 cell).
Battery charger (we recommend a peak detection charger).
8 AA batteries.

BEARING KITS

for the Factory Team kit #7048

R/C two channel surface frequency radio system with one servo.
Battery pack (6 cell).
Battery charger (we recommend a peak detection charger).
Electronic speed control.
R/C electric motor.
Pinion gear, 48 ptich. Teeth to be determined by type and wind of motor.
8 AA batteries.

for the T3 Team kit #7038

R/C two channel surface frequency radio system with one servo.
Battery pack (6 cell).
Battery charger (we recommend a peak detection charger).
Electronic speed control.
R/C electric motor.
Pinion gear, 48 ptich. Teeth to be determined by type and wind of motor.
8 AA batteries.

YOU WILL NEED THESE TOOLS TO ASSEMBLE YOUR KIT

- Phillips screwdriver #2.
- 1/8" flat head screwdriver.
- 5/16" driver or glow plug wrench.
- Needlenose pliers.
- Super glue (cyanoacrylic glue).
- Hobby knife **WARNING!** This knife cuts plastic and fingers with equal ease, so be careful.
- Precision ruler.
- Team Associated Locking Adhesive (#1596)

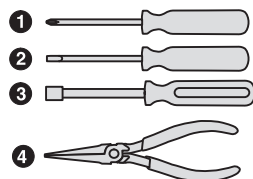

WARNING! Always use hand and eye protection with cyanoacrylic glue!

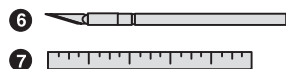

TOOLS SUPPLIED

Allen wrenches, .050", 1/16", 3/32", 5/64".



Molded tools (#6956):

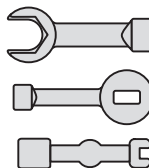

HELPFUL TOOLS (NOT REQUIRED)

- Allen drivers (straight Allen wrenches with hex shaped handles) such as the following made by Associated:
- #6957 .050" Allen wrench
 - #6958 1/16" Allen wrench
 - #6959 5/64" Allen wrench
 - #6960 3/32" Allen wrench
 - #6961 2.5mm Allen wrench
 - Hand drill with 1/8" & 1/4" bits
 - Vernier calipers
 - Hobby scissors
 - Liquid dish soap
 - Nut drivers (screwdriver-handled hex socket tools) such as the following from Associated:
 - #SP-86 3/16" nut driver
 - #SP-85 1/4" nut driver

WARNING!

Do not use a power screwdriver to install screws into nylon, plastic, or composite materials. The fast rotation speed can heat up the screws being installed. They can then break the molded parts or strip the threads during installation.

REACHING US

CUSTOMER SUPPORT

(714) 850-9342
 Fax (714) 850-1744
<http://www.rc10.com/help>
<http://www.rc10.com/kits>



©2000 Associated Electrics, Inc.

ASSOCIATED ELECTRICS, INC.

3585 Cadillac Ave.
 Costa Mesa, CA 92626-1401
 USA
<http://www.rc10.com> <http://www.teamassociated.com>

READ THIS BEFORE BUILDING

READ THE MANUAL!

This manual is for several different T3 kits and will help you assemble and set up each one. Read the manual before starting your kit and before contacting us for help. "Hello, Associated, I need some help." "Did you read the manual?"

OPEN THE BAGS IN ORDER

The assembly is arranged so that you will open and finish that bag before you go on to the next bag. **Sometimes you will have parts remaining at the end of a bag. These will become part of the next bag.** Some bags may have a large amount of small parts. To make it easier to find the parts, we recommend using a partitioned paper plate for spreading out the parts so they will be easier to find.

SUPPLEMENTAL SHEETS

We are constantly updating parts to improve our kits. These changes, if any, will be noted in supplementary sheets located in a parts bag or inside the kit box. Check the kit box before you start and each bag as it is opened. When a supplement is found, attach it to the appropriate section of the manual.

MANUAL FORMAT

The following explains the format of these instructions.

The beginning of each section indicates:

- 1 Which bag to open ("**BAG A**") and which steps you'll be using those parts for ("**FOR STEPS 1-3**").
- 2 Which parts you will use for those steps. Remove only the parts shown. "**1:1**" indicates an actual size drawing; place your part on top and compare it so it does not get confused with a similar part.
- 3 Which tools you should have handy for that section.
- 4 An asterisk (*****) next to a part number indicates the part used in the Factory Team T3 kit. (You can use those numbers to upgrade your T3 kits to Factory Team specs.)
- 5 The instructions in each step are ordered in the order you complete them, so read the words **AND** follow the pictures. The numbers in circles are also in the drawing to help you locate them faster.
- 6 When we refer to left and right sides of the truck, we are referring to the driver's point of view inside the truck.

BAG A

REMOVE THESE PARTS FOR:

Step 1



7210, qty 2
front block carrier,
30° caster



7220, qty 2
front steering
block



6272, qty 4
dust cover

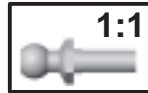

6273, qty 2
ball end



6299, qty 2
E-clip



6951, qty 2
4-40 set screw



4187, qty 4
1/32" thin plastic
washer



7211, qty 2
kingpin ball end



7221, 7221B*, qty 2
front axle

TOOLS USED

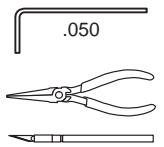

step 1 LEFT SIDE

Asterisk (*****) denotes Factory Team part number.
 Use this number if you have the Factory Team kit.

ASSEMBLE STEERING BLOCKS

- 1 Assemble parts #7220, 6466, 6273 and 6272.
- 2 Push #7221 (7221B*) axle into the #7220 steering block, lining up holes.
- 3 Push the #7211 kingpin through both to clear any burrs. Then remove the kingpin.

ASSEMBLE BLOCK CARRIERS



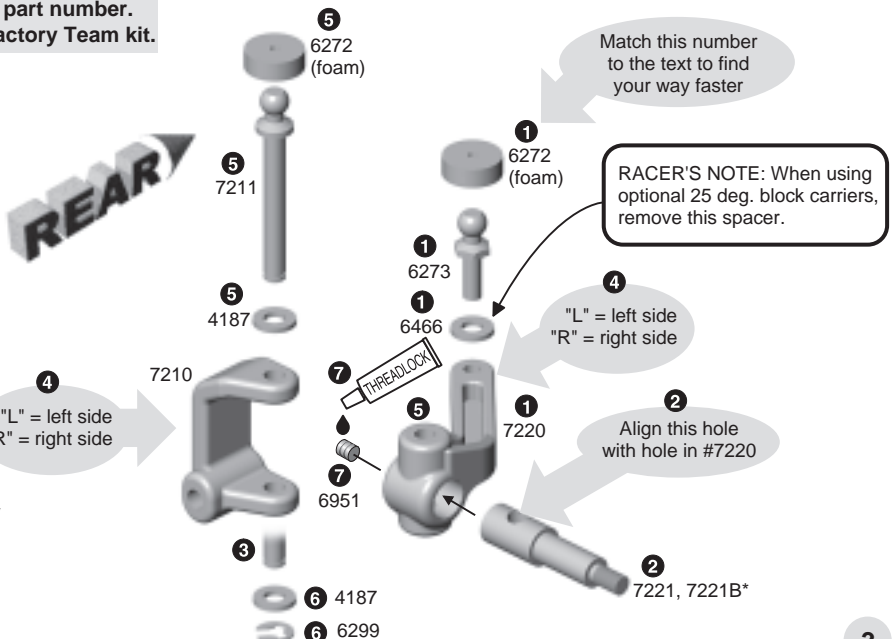











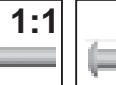
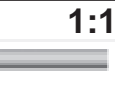

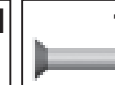
- 4 Note location of L and R on #7210 block carriers and #7220 steering blocks.
- 5 Align holes of #7220 (L) inside #7210 (L). Add one #4187 spacer to #7211 kingpin and insert #7211 through block and axle. Add a #6272 dust cover to the ball end as shown.
- 6 Insert one #4187 spacer and then one #6299 E-clip to the bottom of #7211 kingpin.
- 7 Add screw locking compound such as #1596 Factory Team Locking Adhesive® (not included in kit) to #6951 set screw and tighten into #7221 (7221B*).
- 8 Now assemble right side.

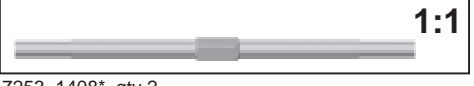

BAG A

REMOVE THESE PARTS FOR:

Step 2

 1:1 9145, qty 2 ball end	 1:1 7260, qty 2 4-40 nut	 1:1 6295, qty 2 4-40 nut	 1:1 6299, qty 8 E-clip	 1:1 6924, qty 3 4-40 x 3/8	 1:1 7413, qty 2 4-40 x 3/4	 1:1 6936, qty 2 #4 washer	 1:1 6922, 6938* qty 4 4-40 x 1/2	
 1:1 7230, qty 4 large ball cup	 1:1 9110, qty 2 front inner hinge pin	 1:1 9115, qty 2 front outer hinge pin	 1:1 7223, 7204*, qty 2 front shock mount	 1:1 7205, 7204*, qty 2 front suspension arm	 1:1 7253, 1408*, qty 2 turnbuckle	 1:1 9125, qty 1 front bulkhead	 1:1 9120, qty 1 cross brace steel	 1:1 7213, 7214*, qty 1 front shock tower

TOOLS USED

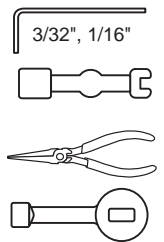

step 2 LEFT SIDE

REMOVE SUSPENSION ARMS

- Twist the #7205 (7204*) suspension arms from the mold runners (shown in black) with your pliers, and trim away remaining molding with your hobby knife.
- Place the #7223 (7204*) front shock mount on the front arm, the taller end of the mount toward the outside of the arm, and secure using two #6922 (6938*) screws.

ARMS TO BULKHEAD

- Attach the block carrier assembly to the #7205 (7204*) suspension arm with its #9115 hinge pin and #6299 E-clips.
- Align the #9125 bulkhead with the suspension arm hinge pin holes as shown. Install #6299 E-clip to one end of #9110 hinge pin. Next hold the #9120 front cross brace in front of the suspension arm while sliding the #9110 hinge pin through the assembly. Install #6299 E-clip to other end of pin. Assemble the other side the same way.

SHOCK TOWER TO BULKHEAD

- Attach the shock screws and hardware #7413, 6936 and 6295. Do other side.
- Attach the #9145 black ball ends and #7260 nuts.
- Attach the #7213 (7214*) shock tower to the #9125 bulkhead with the three #6924 screws.
- Twist #7230 ball cups onto the #7253 (1408*) turnbuckle until you get the dimension shown.
- Add #6272 foam to the ball ends. Connect ball ends with the turnbuckle #7230 ball cups as shown, using your needlenose pliers.

HOW TO USE THE TURNBUCKLE WRENCH

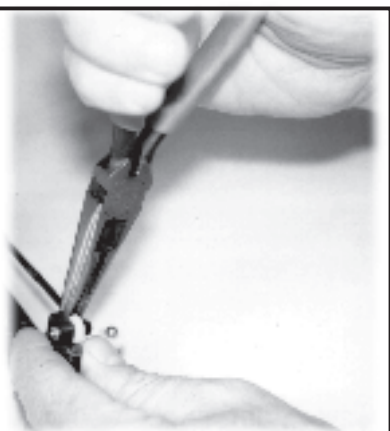
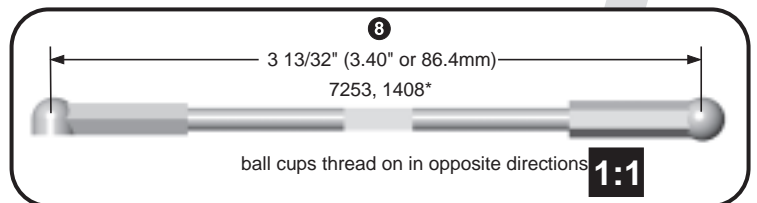
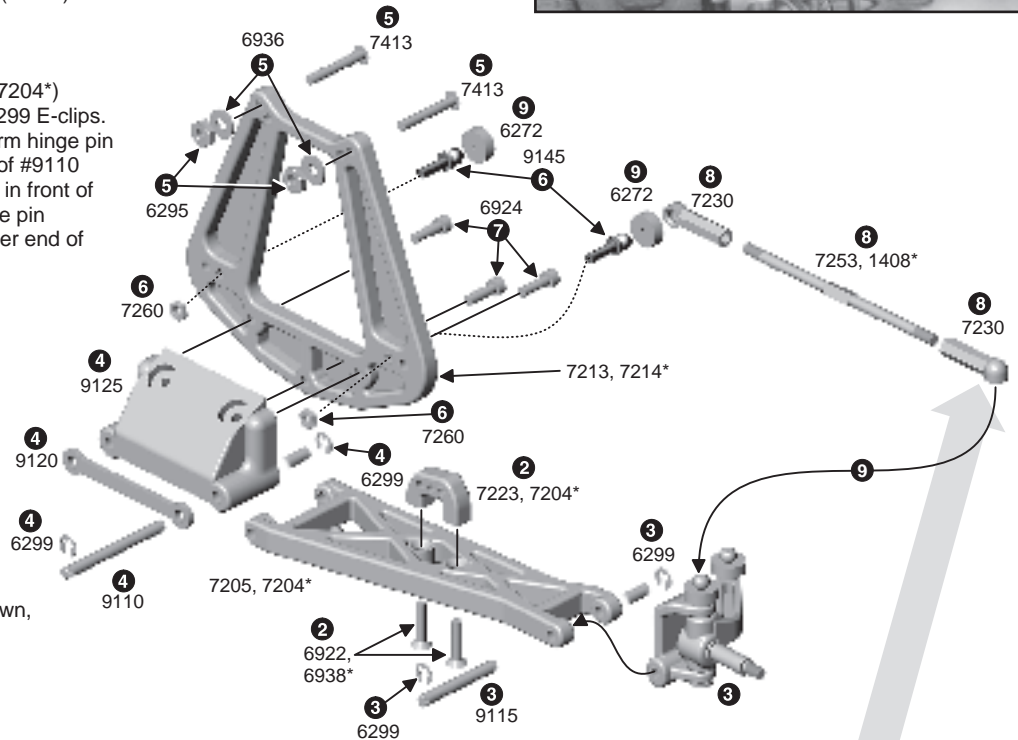
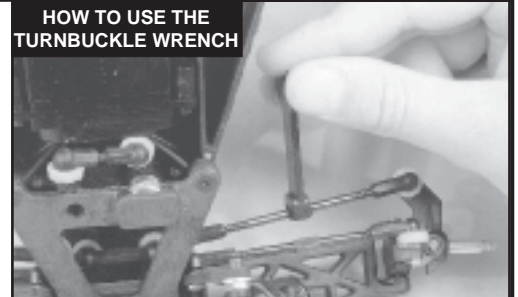

REMOVING BALL CUPS

Hold the cup next to the ball with your pliers and twist the cup off.

VIEWED FROM REAR

COMPLETED FRONT ASSEMBLY



BAG B

REMOVE THESE PARTS FOR:

Steps 1-3



6270, qty 5 ball end



6272, qty 5 dust cover



9155, qty 2 left hand servo saver bushing



9155, qty 1 servo saver arm



9155, qty 1 servo saver arm



9155, qty 1 bell crank



9157, qty 1 servo saver spring



9162*, qty 2 ball bearing OR 9155, qty 2 bushing

TOOLS USED

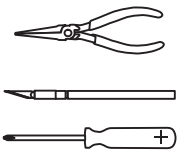

9158, 9156B*, qty 1 adjusting nut



9160, qty 1 mounting pin, right hand



9160, qty 1 mounting pin, left hand



9215, qty 3 6-32 x 3/16



9165, qty 1 drag link



9210, 9210B*, qty 1 kickup



9158, 9156B*, qty 1 tube, aluminum

step 1

KICKUP TO CHASSIS

- 1 Add screw locking compound such as #1596 Factory Team Locking Adhesive (not included in kit) to the three #9215 screws and attach the #9210 (9210B*) aluminum kickup (nose plate) to the #7308 (7309*) chassis.
- 2 Place the two #9160 servo saver/bell crank mounting pins in the locating holes.

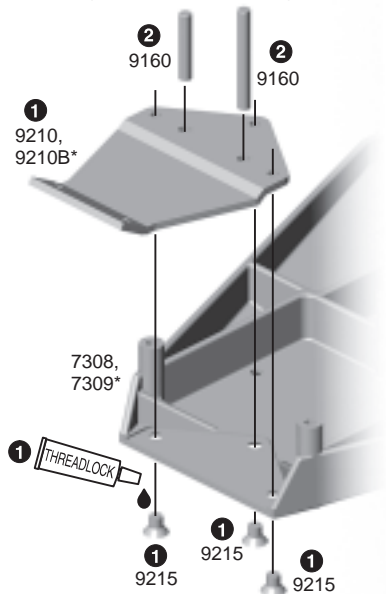

step 2

SERVO SAVER

- 1 Push one #9155 servo saver bushing into each end of the #9158 (9156B*) aluminum tube.
- 2 Slide the two #9155 servo saver arms onto the tube.
- 3 Slide the #9157 spring and #9158 (9156B*) adjusting nut on the tube. Tighten the nut until 1/32" of the tube threads are exposed.
- 4 Add three #6270 ball ends where shown and three #6272 foam dust covers onto them.

BELLCRANK

- 5 Install the two #9155 bushings (or 9162* bearings) into the #9155 bell crank.
- 6 Add two #6270 ball ends where shown and two #6272 foam dust covers onto them.

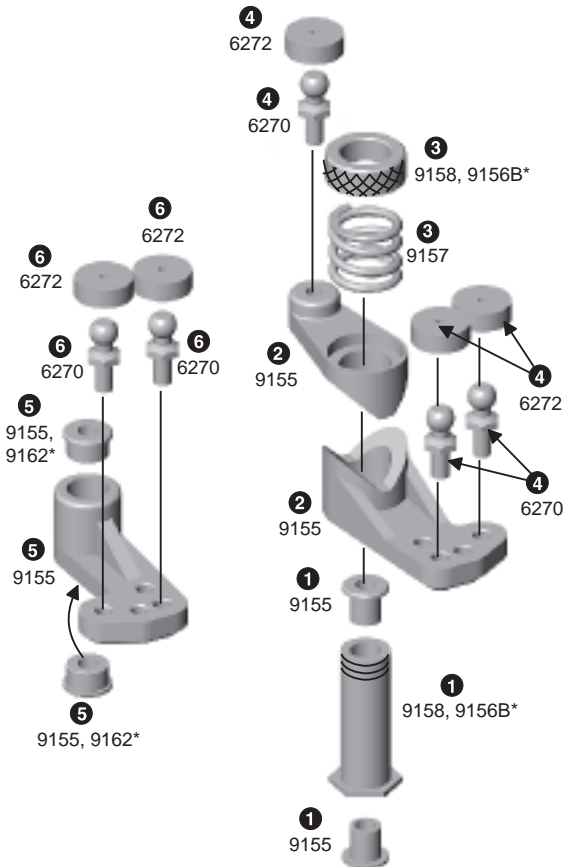

step 3

DRAG LINK

- 1 Install the #9165 drag link over the two ball ends with your needle nose pliers.

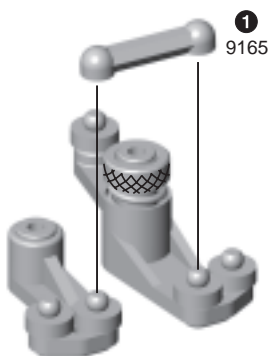

2000

RC Car Action magazine's Reader's Choice Award

1999

RC Car Action magazine's Reader's Choice Award

1998

RC Car Action's Truck of the Year Award

1998

Top Ten Reader's Choice Award RC Car Action magazine

T3

AWARD-WINNING KIT!

BAG B

REMOVE THESE PARTS FOR:

Steps 4-7



6292, qty 2
4-40 x 3/8



6923, qty 2
4-40 x 3/4



7673, 6933*, qty 2
4-40 x 5/16



6918, qty 2
4-40 x 1/2



9130, 9131*, qty 1
front top plate



9220, qty 1
front bumper



7321, qty 1
front body mount

TOOLS USED

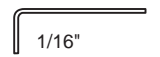

step 4

SERVO SAVER TO CHASSIS

- 1 Place the servo saver assembly over the pins.

TOP PLATE TO CHASSIS

- 2 Line up the #9130 (9131*) front top plate with the servo saver pins and screw holes.
- 3 Bolt down the top plate with two #6923 screws tightly, **then back off both screws one full turn.** This will allow us to accomplish step 5.

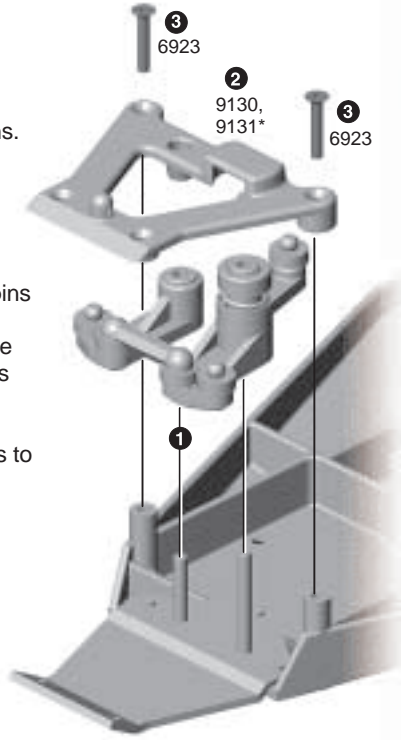

step 5

FRONT END TO CHASSIS

Slip front end under top plate, then push rearward over kickup.

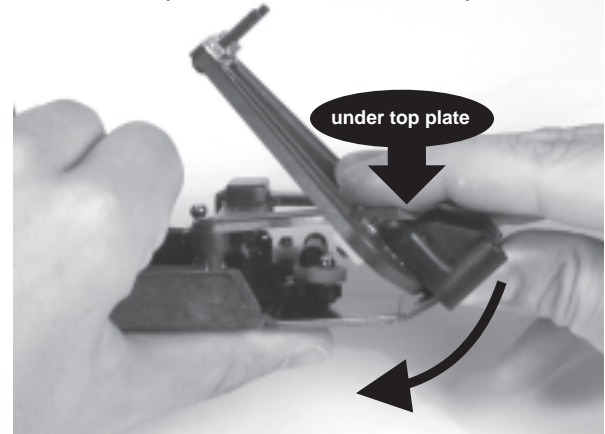

← REAR

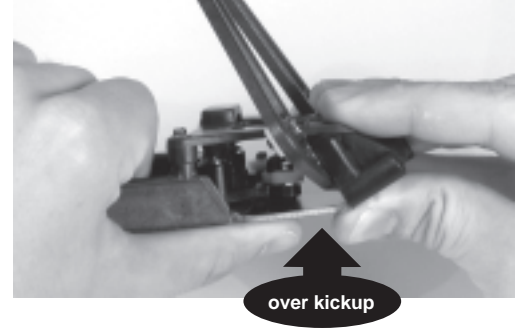

step 6

BUMPER TO CHASSIS

- 1 Add two #6292 screws to secure the front end assembly to the front kickup.
- 2 Go back and tighten the two #6923 screws from Bag B in step 4.
- 3 Bolt on the #9220 bumper with the two #7673 (6933*) screws.

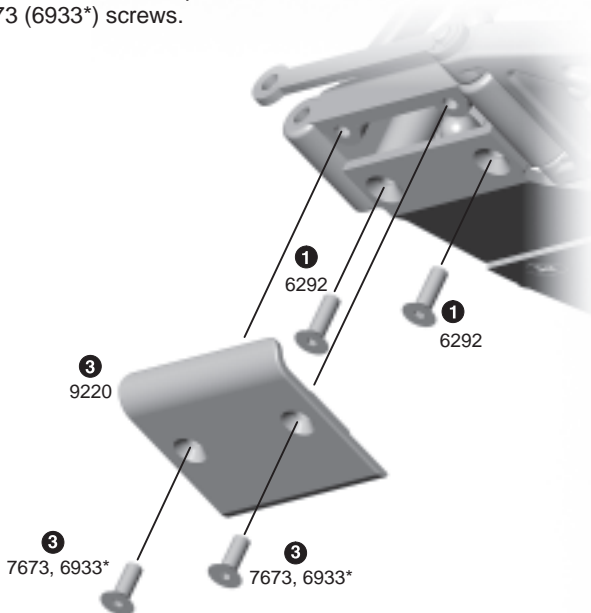

step 7

BODY MOUNT TO CHASSIS

- 1 Secure the #7321 front body mount to the top plate with two #6918 screws.

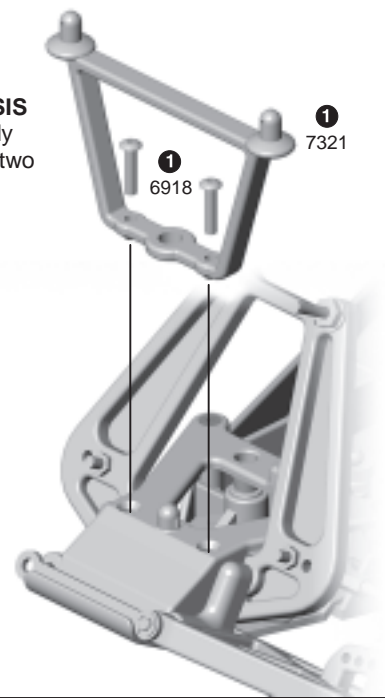

BAG B

REMOVE THESE PARTS FOR:

Step 8



7230, qty 4
large ball cup



7253, 1408*, qty 2
2.62" turnbuckle

TOOLS USED

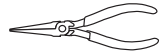

step 8

TURNBUCKLES

- 1 Add #7230 ball cups to two #7253 or 1408* turnbuckles to the dimension shown.
- 2 Pop on the turnbuckles with your needle-nose pliers. Do both sides.

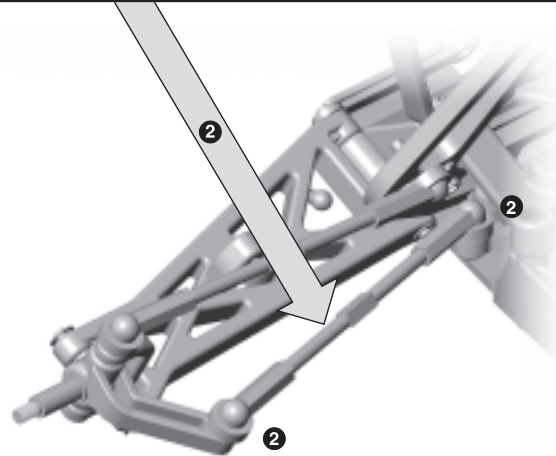
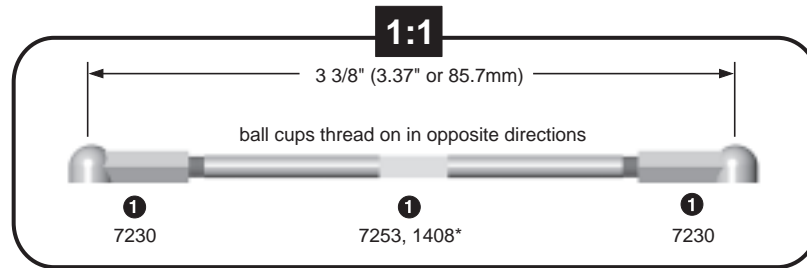

About Tires & Inserts

REAR TIRES

Tire choice is one of the most crucial choices a racer has to make.

How do I know which tire to use?

- The harder the surface, the smaller the pin or spike on the tire. If the surface is soft or has a loose layer on top, the tire pin or spike will become longer to try and get down to the harder surface below.
- The smoother the surface, the softer the tire compound can be. With rougher surfaces, choose medium compound.
- Grass calls for hard compounds.
- Rougher surfaces and many corners favor rounded profile tires for their cornering traction. Smoother surfaces favor flatter profile tires for their maximum flat surface traction.
- Choose the tire that the most successful racers are using at that track. This saves you money--it keeps you from buying tires that won't work on the track.

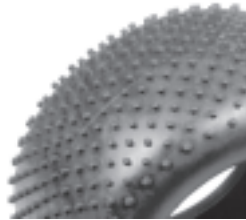

TIPS FOR TIRES

1. With one piece rims, glue the tires to the rims with CA.

Remember afterwards to vent the tires with a small hole so they won't bounce.

2. Try applying tire traction compound to all four tires when encountering slick surfaces. Use traction compound when on dry, clean tracks when you need more traction, especially through the corners.

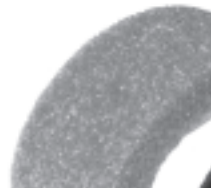

TIP FOR INSERTS

1. Trim your foam inserts at the inside edge of the foam. This will allow the beads of the tire to fit to the rim better and the foam will also support the tire much better.

FOAM TIRE INSERTS

Today's tires are thin and need support to retain their shape. Tire inserts give this support.

How do I know which foam to use?

- The foam insert's density is important. The foam insert that comes with the tires nine times out of ten is the insert you should use.
- Too firm an insert will cause your car to bounce, resulting in loss of traction.
- Too light a foam will cause the car to wander and to be very unstable.

(This information and more is found in the **Complete Tuning Guide: T3** booklet. For more about this booklet, turn to page 30.)

BAG C

REMOVE THESE PARTS FOR:

Steps 1-3



7260, qty 2



6272, qty 2
dust cover

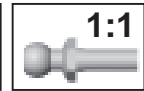

6273, qty 2
ball end



6292, qty 4
4-40 x 3/8



6299, qty 4
E-clip

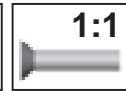

9269, qty 4
5-40 x 1/2



6936, qty 2
#4 washer

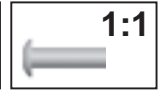

6917, 6860*, qty 4
4-40 x 3/8



9260, qty 2
rear inner hinge pin



9267, qty 2
rear suspension mount, 3-3
(3° toe-in, 3° anti-squat)



9241, 9241B*, qty 1
rear chassis plate



7340, 7339*, qty pr
rear suspension arm



7341, 7339* qty pr
rear shock mount

TOOLS USED

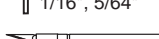
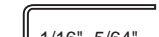
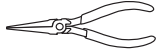

step 1

TRIM SUSPENSION ARMS

- 1 Twist the #7340 (7339*) suspension arms from the mold runners (shown in black) with your pliers, and trim away the remaining molding with your hobby knife.

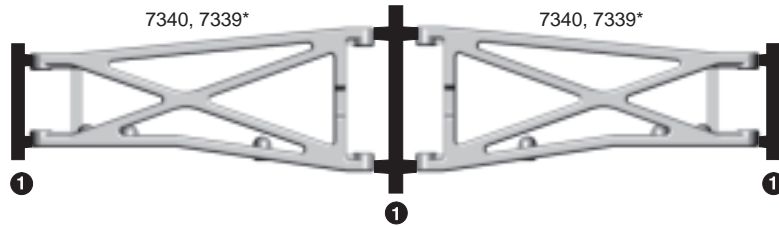

step 2 LEFT SIDE

REAR PLATE TO CHASSIS

- 1 Attach the two #9267 (3-3) rear suspension arm mounts to the #9241 (9241B*) chassis plate with two #9269 5-40 x 1/2 screws and a single #6936 washer as shown. These mounts are marked L3-3 (left) and R3-3 (right). The coding stands for 3° toe in and 3° anti-squat. *NOTE: by using the #4 washer, your anti-squat is effectively reduced to 1.5°.*
- 2 Fasten the chassis plate to the bottom of the chassis with four #6292 screws.
- 3 Add two #6273 ball ends to the inside holes of the chassis, then thread on the #7260 nuts to the ball ends. Then add the #6272 foam dust covers.

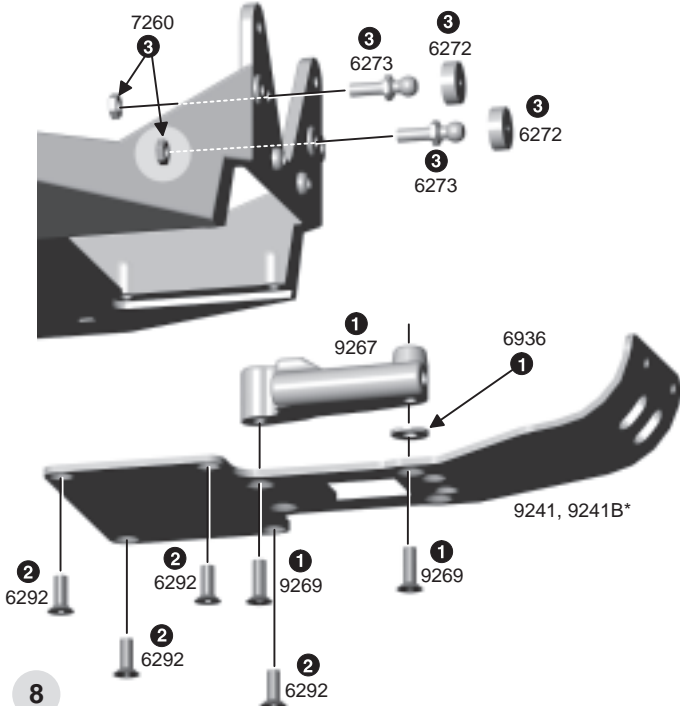

step 3 LEFT SIDE

SUSPENSION ARMS TO MOUNTS

- 1 Attach the #7341 (7339*) left shock mount to the #7340 (7339*) left suspension arm with two #6917 (6860*) screws. Both mount and arm are labeled "L".
- 2 Attach the #7340 (7339*) left suspension arm to the #9267 left mount with the #9260 hinge pin and #6299 E-clips.
- 3 Now do the right side.

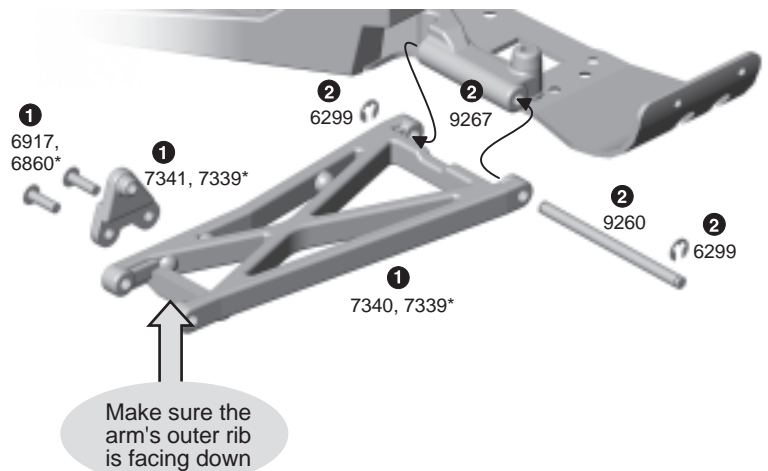

Make sure the arm's outer rib is facing down

BAG D

REMOVE THESE PARTS FOR:

Steps 1-5



6573, qty 2
diff thrust washer



6574, qty 6
diff thrust ball



6575, qty 1
T-nut



6575, qty 1
diff thrust bolt cover, nylon



6575, qty 1
2-56 diff bolt



6581, qty 12
diff balls



6582, qty 1
diff spring



6588, qty 1
black grease



6591, qty 1
diff lube



9365, qty 1
diff gear



9367, qty 2
diff drive ring



9370, qty 1
left diff outdrive hub

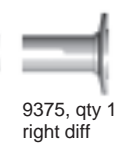

9375, qty 1
right diff outdrive hub

TOOLS USED

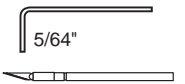

step 1

SET UP DIFF GEAR

- 1 Add a generous amount of #6591 diff lube to the #9365 diff gear ball holes and push in the twelve #6581 diff balls. Then push in the lube that was pushed out.
- 2 Insert one #6597 bushing or #6589 bearing into the gear.

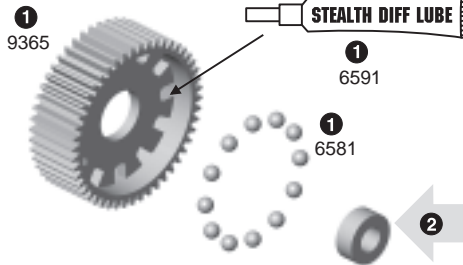

BEARING KITS	BUSHING KITS
1:1	1:1
6589, qty 1 5/32 x 5/16 ball bearing	6597, qty 1 5/32 x 5/16 bushing

step 2

LEFT OUTDRIVE HUB

Push in the #6582 spring and #6575 T-nut.

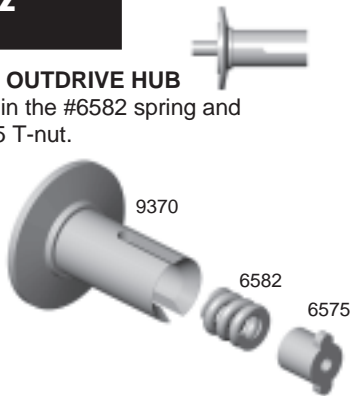

step 3

RIGHT OUTDRIVE HUB

- 1 Slide one #6573 washer onto the #6575 bolt. Apply a generous amount of #6588 black grease to the washer on the side facing away from the bolt head.
- 2 Stick six #6574 balls into the grease against the bolt and washer. Add the other #6573 washer. The grease will hold the balls in place during assembly.
- 3 Slide all this into the #9375 right outdrive hub, being careful not to lose any of the balls.
- 4 Insert the #6575 bolt cover.

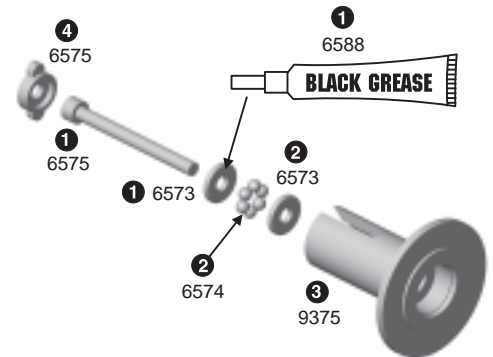

step 4

RIGHT OUTDRIVE HUB

- 1 Insert one #6597 bushing or #6589 bearing into the #9375 right hub.
- 2 Add a **light** coat of #6591 diff lube to right hub where shown.
- 3 Place a #9367 diff drive ring and then the gear assembly on the hub.

ASSEMBLE THE HUBS

- 4 Add a **light** coat of #6591 diff lube to left hub where shown.
- 5 Place a #9367 diff drive ring on the hub.
- 6 Push the #9370 left hub over the diff bolt and center the hub.

CHECK ALIGNMENT OF HUBS

- 7 Tighten the diff with your 5/64" Allen wrench, but not completely.
- 8 Rotate the diff hubs several times as you are tightening the bolt to check for proper alignment of the parts.
- 9 We'll adjust the diff on the next page.

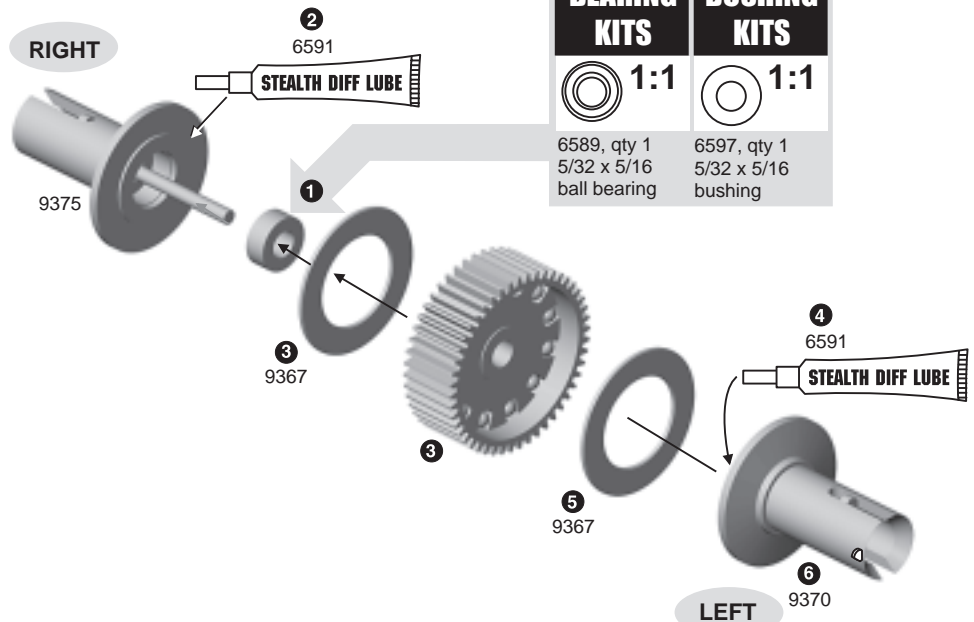

BEARING KITS	BUSHING KITS
1:1	1:1
6589, qty 1 5/32 x 5/16 ball bearing	6597, qty 1 5/32 x 5/16 bushing

step 5

ADJUST THE DIFFERENTIAL

① As you tighten the diff bolt, you will notice the T-nut ears moving closer to the bottom of the diff hub slot. This compresses the spring behind the T-nut. The spring should be fully compressed at the same time the T-nut reaches the end of the slot. **Caution:** Pay close attention to feeling when

the spring is fully compressed. **Do not overtighten the bolt.** When you feel the spring fully compressed, loosen the diff bolt 1/8 of a turn. No more, no less. Your diff should now operate very smoothly when turning the hubs in opposite directions. After you have driven the car once, recheck the diff adjustment. Never adjust the diff any other way.

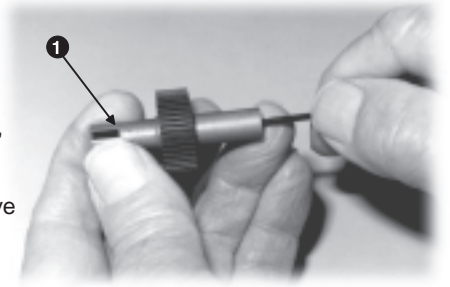

BAG D

REMOVE THESE PARTS FOR:
Steps 6-7



6292, 6934*, qty 1
4-40 x 3/8



9352, qty 1
right tranny case



6571, qty 1
top shaft/gear



9352, qty 1
left tranny case



6572, qty 1
drive shaft
roll pin



9360, qty 1
idler gear



6928, 6935*, qty 3
4-40 x 1

9361, qty 1
idler gear shaft



7337, qty 3
washer, gold



7669, qty 2
top shaft
spacer

TOOLS USED

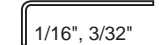
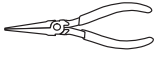

1/16", 3/32"

step 6

ADD BUSHINGS OR BEARINGS TO THE CASE HALVES

- ① Cut the two #9352 transmission case halves and the three #9352 spacers from the runner.
- ② Add bushings or bearings to each case half.

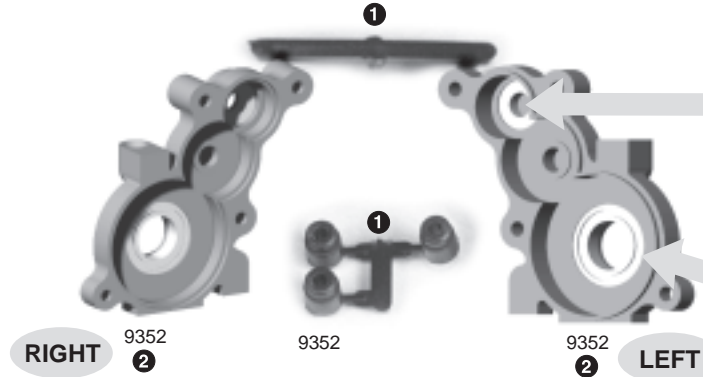

BEARING KITS



3977, qty 2
3/16 x 3/8
unflanged bearing



3976, qty 2
3/8 x 5/8
unflanged bearing

BUSHING KITS



6599, qty 2
3/16 x 3/8
bushing



6598, qty 2
3/8 x 5/8
bushing

step 7

INSIDE THE TRANNY

- ① Install the right side diff assembly into the right case. (Insert the side that has the diff bolt head showing.)
- ② Add the #7669 spacer to the #6571 drive shaft and put both into the right case.
- ③ Install the two bushings or bearings in the #9360 gear, followed by the #9361 shaft. Insert the assembly into the right case.
- ④ Add the other #7669 spacer to the #6571 shaft and put the case halves together.

OUTSIDE THE TRANNY

- ⑤ Screw the halves together with one #6292 (6934*) bolt.
- ⑥ Insert the #6572 roll pin into the shaft hole with your needlenose pliers.
- ⑦ Push the three #6928 (6935*) bolts through, each with its own #7337 washer.

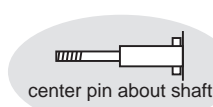
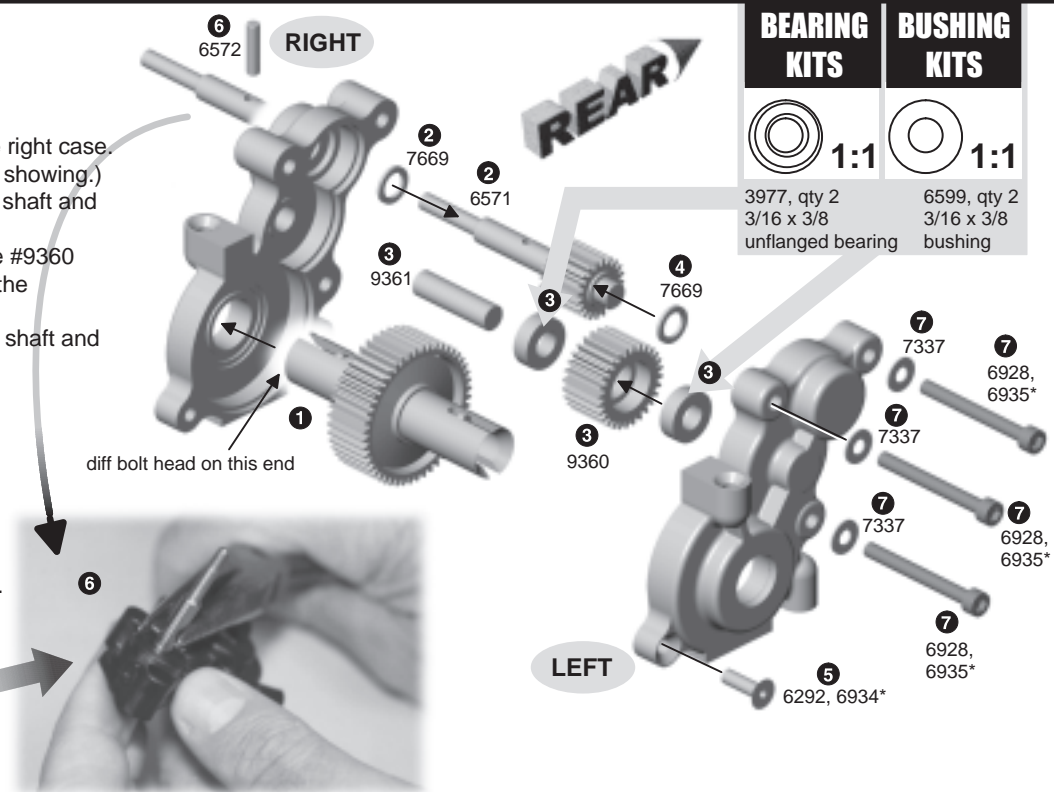

center pin about shaft

BAG D

REMOVE THESE PARTS FOR:

Steps 8-11

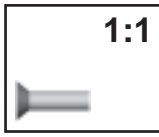

6292, 6934*, qty 2
4-40 x 3/8



6568, qty 4
4-40 x 3/16



9352, qty 3
motor plate
spacer



9251, qty 1
inner torque
clutch hub



9252, qty 1
outer torque
clutch hub



9253, qty 1
clutch disc



6587, qty 1
torque control
spring

TOOLS USED

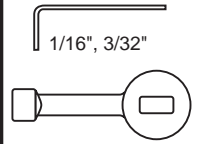

6594, qty 2
thrust bearing
washer (thin)



6594, qty 1
thrust bearing
(thick gold)

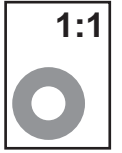

6599, qty 1
3/16 x 3/8
bushing



6629, qty 1
5-40 locknut



6695, qty 1
87T 48 pitch
Stealth spur gear

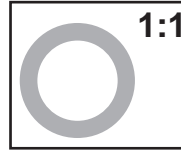

7373, qty 1
motor plate gasket
foam

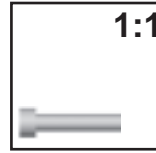

7874, 7873*, qty 2
4-40 x 7/16



9245, 9245B*, qty 1
motor plate



9380, 9381*, qty 1
rear transmission
brace

step 8

REMOVE THE BACKING

- 1 Remove the backing and center from the #7373 gasket.

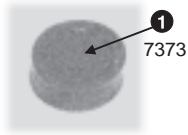

step 9

INSTALL THE MOTOR PLATE

- 1 Center the #7373 gasket around the large round hole of the #9245 (9245B*) plate.
- 2 Install the three #9352 spacers.
- 3 Line up the #9245 (9245B*) plate and fasten with the three #6928 (6935*) screws.

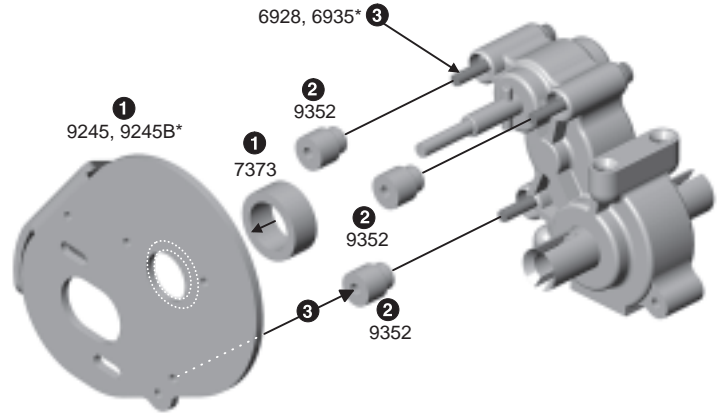

step 10

INSTALL THE ASSOCIATED TORQUE CLUTCH (ATC)

- 1 Add the #9251 inner hub to the shaft, lining up the notch with the roll pin.
- 2 Install the #9253 clutch disc into the inner hub, then add the #9252 outer hub and #6599 bushing.
- 3 Install parts in the following order: #6594 (silver thin), #6594 (gold thick), #6594 (silver thin), #6587 black spring, #6629 locknut.
- 4 Orient the #6695 spur gear side facing out as shown and mount to #9252 with two #6568 screws.
- 5 Tighten the #6629 locknut so the end of the shaft is flush with the end of the nut. This is a good initial adjustment. For further info on the torque clutch, see the tuning section on page 27.

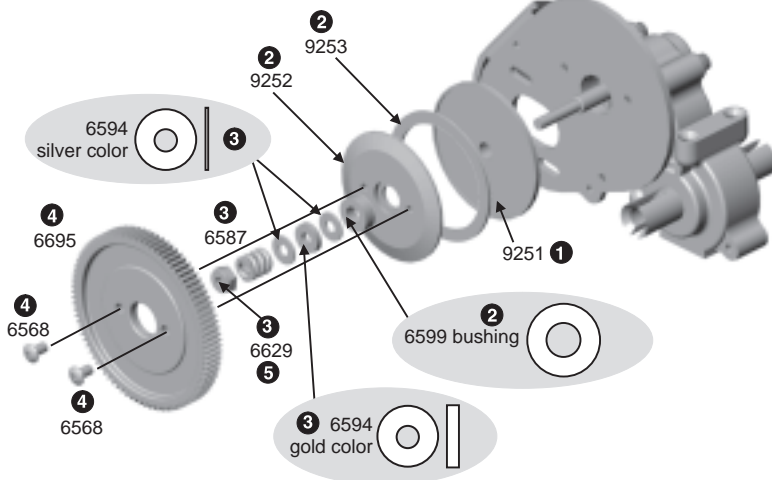

step 11 LEFT SIDE

MOUNT THE TRANSMISSION

- 1 Mount the #9380 (9381*) brace with two #7874 (7873*) screws.
- 2 Mount the tranny with the two #6292 (6934*) screws from below, lining up the motor plate holes as shown.
- 3 Bolt the motor plate to the rear chassis with two #6568 screws.

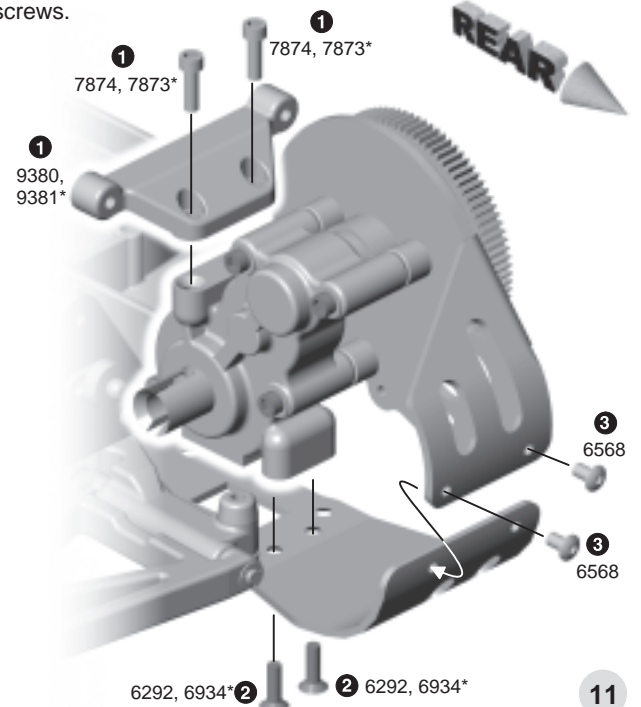

TEAM & FACTORY TEAM KITS ONLY

BAG E

REMOVE THESE PARTS FOR: Steps 1-2

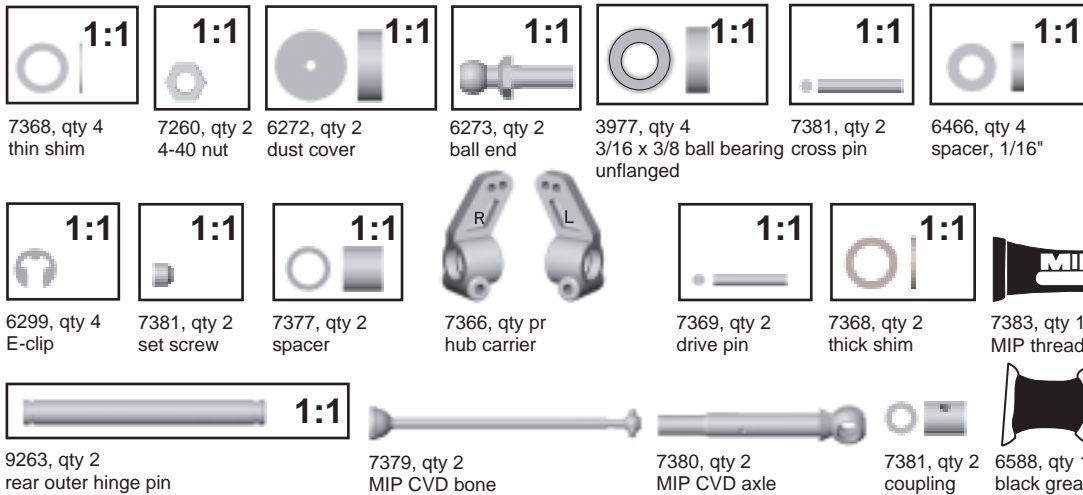

TOOLS USED



step 1 TEAM/FT

TEAM/FT ONLY: ASSEMBLE MIP CVD'S

- Spread some #6588 Associated black grease inside the #7380 axle hole where shown, then on the #7381 coupling. Slide the coupling into the axle.
- Slide the #7380 axle into the #7379 dogbone, aligning the cross holes.
- Insert the #7381 cross pin, spacing it evenly on both sides of the bone.
- Add the #7383 MIP thread lock to the #7381 set screw. Angle and turn the CVD so the set screw can be screwed in with the Allen wrench.
- Repeat steps 1-4 for the remaining CVD.
- Slide two #7368 thin shims onto the #7380 axle. Slide one #3977 unflanged bearing onto the axle. Push the CVD assembly into the back of the #7366 rear hub carrier. Slide one #7377 spacer into the hub carrier from the front followed by the second #3977 bearing.
- Slide one #7368 thick shim onto the axle.
- Install the #7369 drive pin with your needlenose pliers.
- Assemble the other hub carrier.
- Thread on the #6273 ball end into the hole shown and add the #7260 nut to the other side. (When you do the other hub carrier, thread the ball end into the other side so both ball ends will point to the front when assembled.) Add a #6272 dust cover to the ball ends.

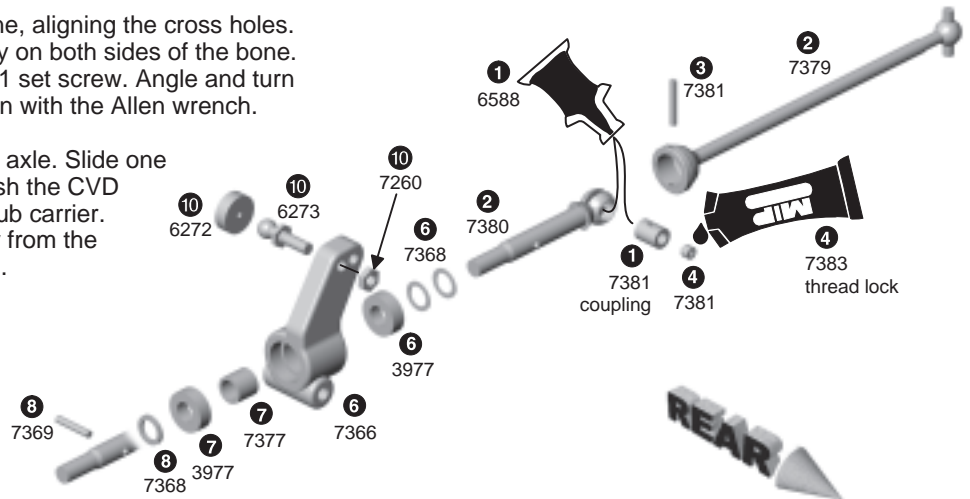

step 2 TEAM/FT

TEAM/FT ONLY: MOUNT REAR HUB CARRIERS

- Place the left rear hub carrier assembly and two 1/16" #6466 spacers between the holes as shown. The spacers are on the back side of the hub carrier, shortening the wheelbase.
- Install the #9263 hinge pin through the arm and hub carrier. Install two #6299 E-clips.
- Follow steps 1 & 2 for the right side.

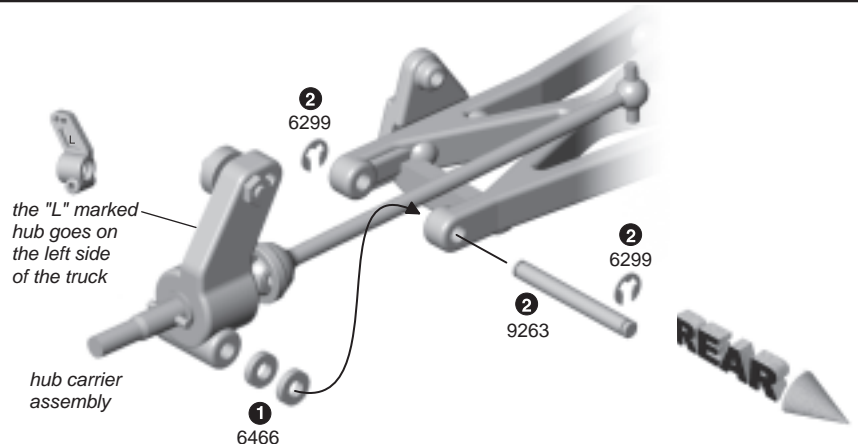

BASIC, SPORT, RTR, ARR ONLY

BAG E

REMOVE THESE PARTS FOR: Steps 1-2



6466, qty 4
1/16" spacer



6299, qty 4
E-clip



7369, qty 2
drive pin



7368, qty 4
thin shim



6599, qty 4
3/16 x 3/8 bushing
unflanged



5407, qty 2
O-ring

TOOLS USED

.050"



9263, qty 2
rear outer hinge pin



7361, qty 2
dogbone



7260, qty 2
4-40 nut



6272, qty 2
dust cover

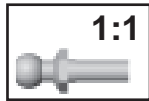

6273, qty 2
ball end



7366, qty 2
hub carrier



7378, qty 2
stub axle

step 1 BASIC, SPORT, RTR, ARR trucks

ASSEMBLE REAR AXLES

- 1 Install a #6599 bushing into both ends of the #7366 left hub carrier.
- 2 Push the #7378 axle into the #7366 hub carrier.
- 3 Slide two #7368 thin shims onto the end of the axle.
- 4 Push the #7369 drive pin into the axle hole and center both ends outside.
- 5 Thread on the #6273 ball end into the hole shown and add the #7260 nut to the other side. (When you do the other hub carrier, thread the ball end into the other side so both ball ends will point to the front when assembled.) Add a #6272 dust cover to the ball end.
- 6 Slide the #7361 dogbone into the axle.

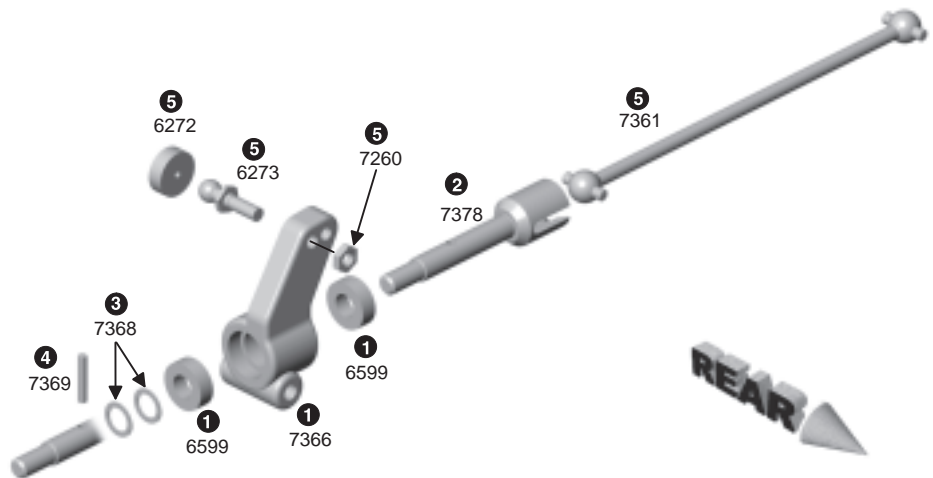

step 2 BASIC, SPORT, RTR, ARR trucks

MOUNT REAR HUB CARRIERS

- 1 Push the #5407 O-ring into the outdrive of the transmission, then the dogbone and hub carrier assembly into the transmission outdrive. The dogbone pins should slide into the slots of the outdrive.
- 2 Place the hub carrier assembly and two 1/16" #6466 spacers between the arms holes. The spacers are on the back side of the hub carrier, which pushes the hub carrier closer to the front axle, shortening the wheelbase.
- 3 Install the #9263 hinge pin through arm, spacers and hub carrier. Install two #6299 E-clips.
- 4 Assemble and mount the other side.

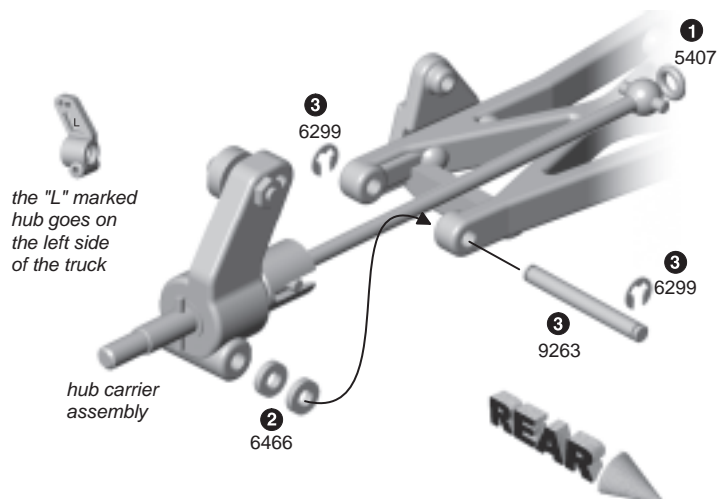

ALL KITS

BAG E

REMOVE THESE PARTS FOR:

Steps 3-4



7253, 1408*, qty 2
2.62" turnbuckle

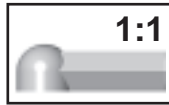

7230, qty 4
large ball cup



7260, qty 2
4-40 nut



7413, qty 2
4-40 x 3/4

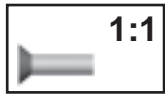

6292, 6934*, qty 2
4-40 x 3/8

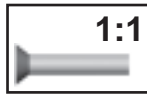

6915, qty 2
4-40 x 5/8



7351, 7349*, qty 1
rear shock tower

TOOLS USED

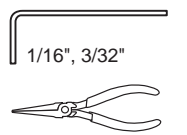

step 3 REAR VIEW

COMPLETED REAR ASSEMBLY

ADD TURNBUCKLES

- 1 Twist #7230 ball cups onto the #7253 (1408*) turnbuckle until you get the dimension shown. **Ball cups will face in opposite directions.**
- 2 Connect ball ends with the turnbuckle ball cups as shown, using your needlenose pliers. Assemble both right and left sides.

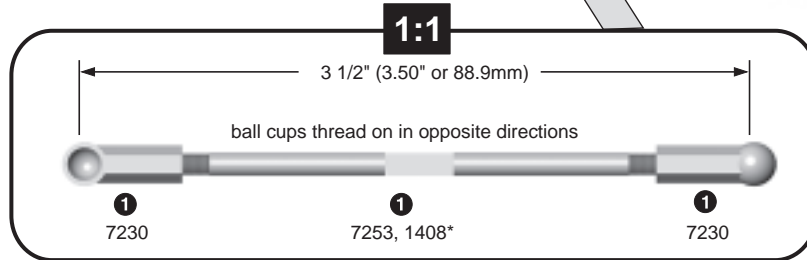
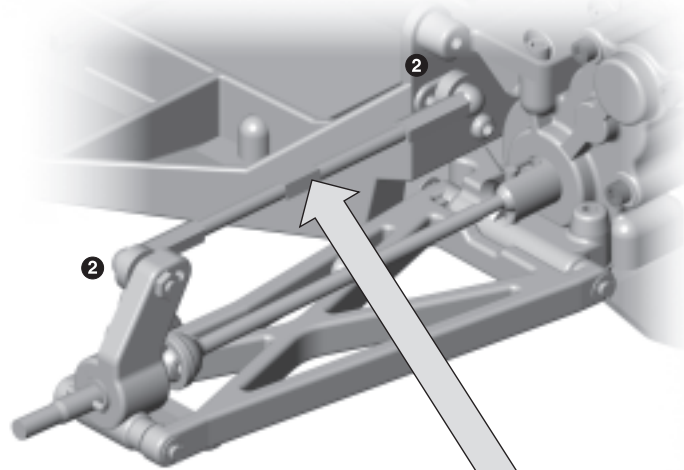

step 2 LEFT SIDE

MOUNT THE REAR SHOCK TOWER

- 1 Orient the tower outward as shown and mount to bulkhead with #6292 (6934*) screws.
- 2 Fasten the tower to the transmission brace with the #6915 screws.
- 3 Add two #7413 screws in the middle holes at top, then thread on #7260 nuts.

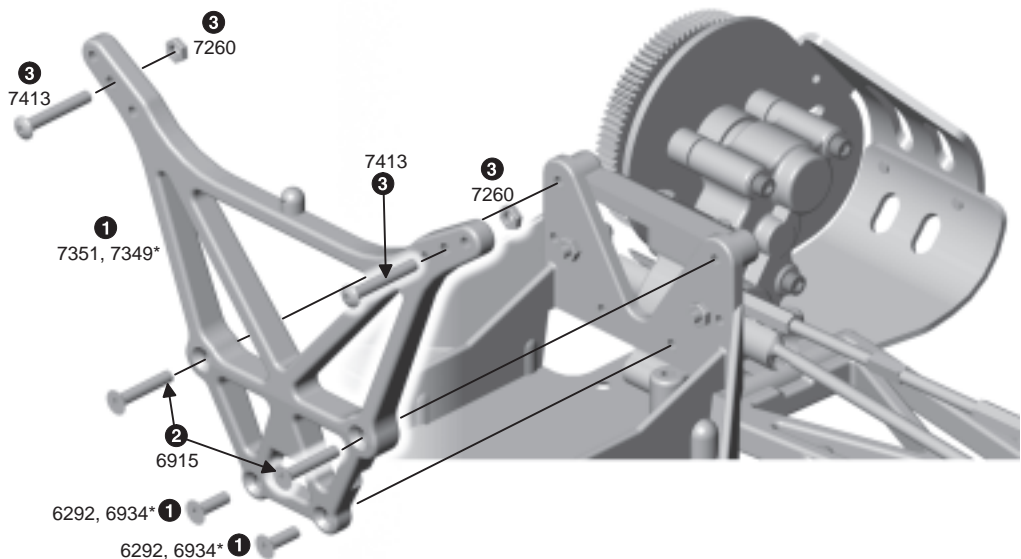

BAG F

REMOVE THESE PARTS FOR: Steps 1-2



6465, qty 2 shock piston #1



6465, qty 2 shock piston #2



6440, qty 4 split locking washer



6440, qty 8 small spacer



6440, qty 4 large spacer



5422, qty 1 30 wt oil

TOOLS USED



6429, qty 1 shock assembly tool



TEAM/FT 7410, qty 2 1.39 rear shock body



BASIC/SPORT 7411, qty 2 gold 1.39 rear shock body



TEAM/FT 6436, qty 2 1.02 front shock body



BASIC/SPORT 6425, qty 2 gold 1.02 front shock body



5407, qty 8 red O-ring



RTR, ARR 6424B, qty 2 blue 1.32 rear shock body

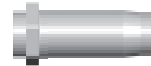

RTR, ARR 6425B, qty 2 blue 1.02 front shock body

step 1

TRIM SHOCK PISTONS

- 1 Burrs interfere with smooth shock action within the shock body. To remove from tree without creating burrs, twist up, not down. Remove two each of #1 and #2.
- 2 Remove remaining burrs carefully with hobby knife.

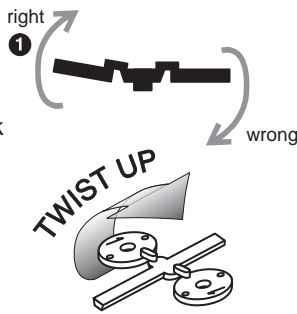

REMOVE SHOCK PARTS

- 3 Remove the #6440 shock parts from the molding tree carefully so no part of the molding runner remains. It is safer to remove a tiny amount of the shock part than to risk the chance of a burr remaining on the part. Short blade scissors or a hobby knife will work.



step 2

- 1 Install the shock parts onto the #6429 shock tool as shown. One shock clip (split locking washer), one thin spacer, one red O-ring, one thick spacer, one red O-ring, and one thin spacer.
- 2 Remove the #5422 oil and add 3-4 drops to the inside of the shock body and to the seal parts.
- 3 Insert the tool and the seal parts into the shock body all the way. Push easily until the parts snap into place.
- 4 Check the tool height in fig. 2-4. The left shock shows just before snapping into place, the right shows after.
- 5 Assemble the remaining shocks the same way. *If your shocks do not snap together easily, check the internal parts for burrs again.*

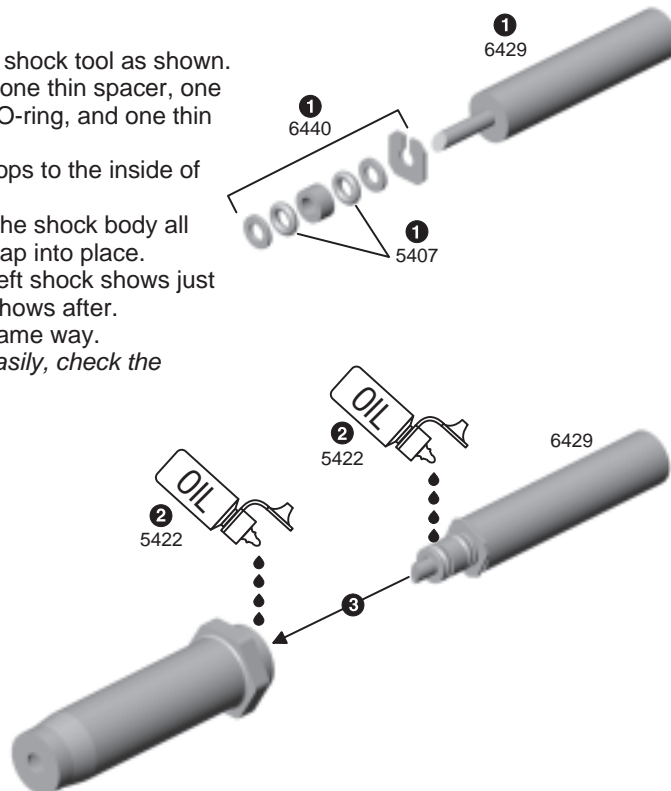
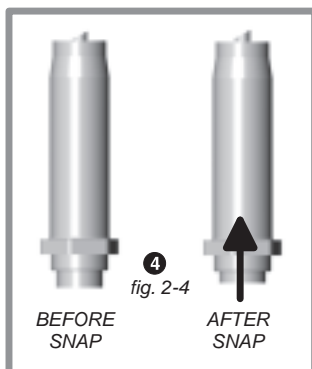

DISMANTLING SHOCK PARTS

Here is how to dismantle the shocks when it's rebuild time. Put the shock assembly tool into the bottom of the shock until it rests against the small washer as shown, then push to unclip the shock clip (split locking washer).

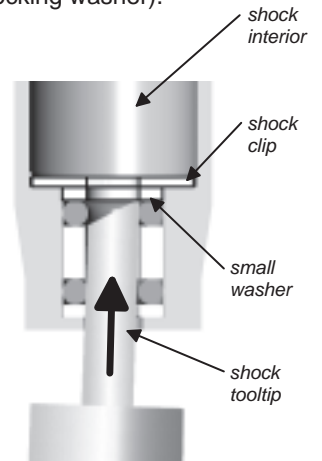

BAG F

REMOVE THESE PARTS FOR: Steps 3-4



6469, qty 4 large O-ring



6459, 6417*, qty 2 1.02 front shock shaft



6458, 6416*, qty 2 1.32 rear shock shaft



6299, qty 8 E-clip



7217, qty 4 pivot ball



7217, qty 4 eyelet

TOOLS USED

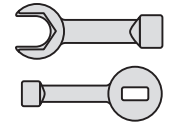

6465, qty 2 shock piston #1 (for rear shocks)



6465, qty 2 shock piston #2 (for front shocks)



6428, qty 4 shock cap



5422, qty 1 30 wt oil

step 3

ASSEMBLE SHOCKS

- 1 Install the #6469 large O-ring over the thread of each shock body.
- 2 On the #6459 (6417*) front shock shaft, install a #6299 E-clip on both sides of the #6465 (#2) piston from step #1.
- 3 On the #6458 (6416*) rear shock shaft, install a #6299 E-clip on both sides of a #6465 (#1) piston from step #1.
- 4 Insert the shock shaft assemblies into the shock bodies.
- 5 Push the #7217 pivot ball and eyelet together.
- 6 As you hold the shaft with a rag and needlenose pliers next to the threads, screw the eyelet onto the end of each shock shaft.

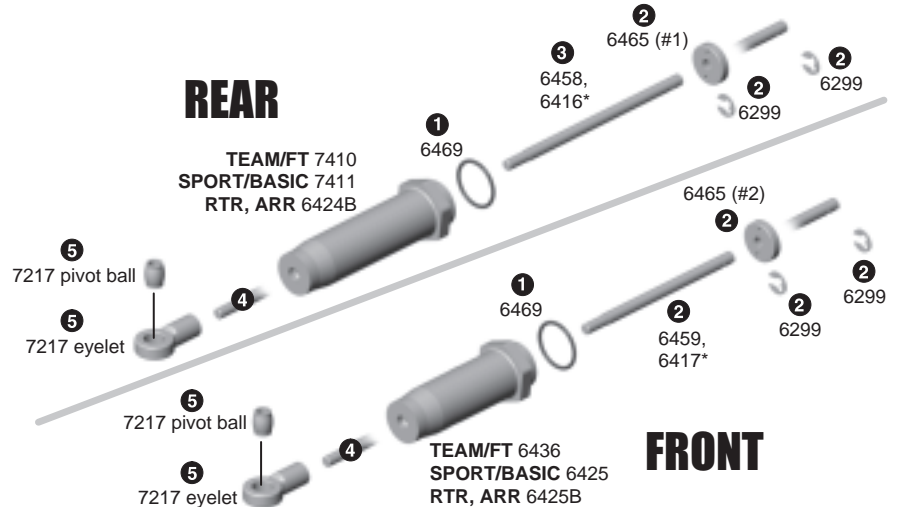

step 4

FILLING THE SHOCKS

- 1 Holding the shocks upright, fill with oil to the top of the shock body.
- 2 Slowly move the shaft up and down several times to allow air bubbles to escape to the top.
- 3 Refill with oil to the top of the shock body.
- 4 Push the shaft in until the piston is level with top of shock body. The oil will slightly bulge up above the shock body.
- 5 Fill the #6428 shock cap about halfway with oil and install it onto the body. Try to retain as much oil as possible during assembly. The shaft will extend out as you tighten the cap down.



SETTING THE REBOUND

- 6 Move the shock shaft in and out a few times and then push it all the way in. It should be easy to push the shaft in until the eyelet hits the body.

- 7 Then the shaft should push itself out approximately 1/4" to 3/8" (6.3mm - 9.5mm).
- 8 If the shock does not push out this far, there is not enough oil in them. Add just a little oil and try steps 6-7 again.
- 9 If the shocks push out farther than the distance in step seven, or you cannot push the shaft in until the eyelet hits the body, there is too much oil. Loosen the cap a half turn (with the shaft extended) and pump out a small amount of oil by pushing the shaft in. Retighten the cap and try steps 6-7 again.

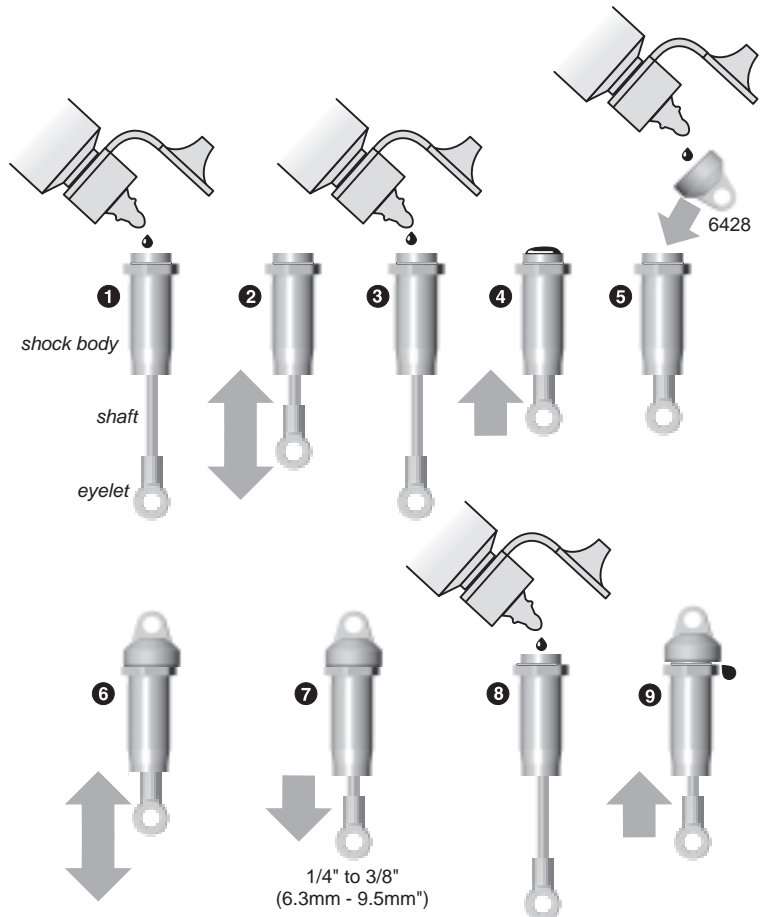

BAG F

REMOVE THESE PARTS FOR:
Step 5



8846, qty 2- 1/16", 2-1/8", 2-1/4" preload spacers

1:1



6475, qty 4 spring collar



6475, qty 4 spring cup



BASIC/SPORT TEAM/FT
6480, qty 2 rear green spring



RTR, ARR
6478, qty 2 rear silver spring



BASIC/SPORT TEAM/FT
7427, qty 2 front green spring



RTR, ARR
7428, qty 2 front silver spring

TOOLS USED

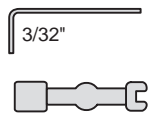

step 5

FINISH SHOCKS

- Slide one #8846 1/4" preload spacer onto the rear shock body.
- Slide one #8846 1/16" and one 1/8" preload spacer onto the front shock body.
- Slide on the #6475 spring collar, then springs on the rear shocks, and springs on the front shocks.
- Compress the springs to add the #6475 spring cup.

REAR



8846



1/4"

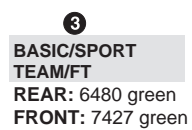

BASIC/SPORT TEAM/FT
REAR: 6480 green
FRONT: 7427 green

3 6475 spring collar

RTR, ARR
3 REAR: 6478 silver
FRONT: 7428 silver

FRONT

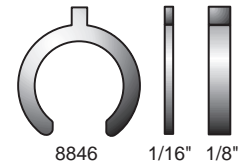

8846

1/16" 1/8"

BAG F

REMOVE THESE PARTS FOR:

Steps 6-7



6472, qty 4 4-40/5-40 locknut



6473, qty 4 shock bushing



6918, qty 4 4-40 x 1/2

TOOLS USED

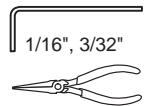

step 6 RIGHT SIDE

REAR SHOCK MOUNTING

- Add the #6473 bushings as shown.
- Push shock cap over bushing and add #6472 locknut. Do not overtighten or the shock will bind.
- Fasten the lower shock with the #6918 screw into the arm outer hole.
- Do the other rear shock.

in middle hole of shock tower

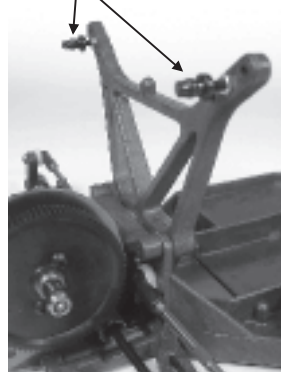

2 6472



3 6918

← REAR

step 7 RIGHT SIDE

FRONT SHOCK MOUNTING

- Add the #6473 bushings as shown.
- Push shock cap over bushing and add #6472 locknut. Do not overtighten or the shock will bind.
- Fasten the lower shock with the #6918 screw into the arm's middle hole.
- Do the other front shock.

in outer hole of shock tower

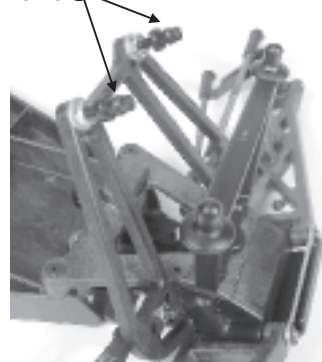

2 6472

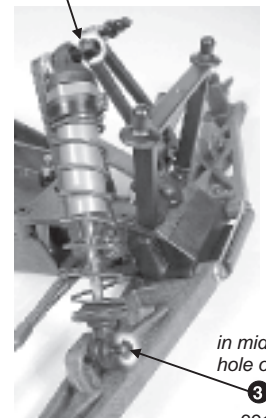

in middle hole of arm

3 6918

← REAR

BAG G

REMOVE THESE PARTS FOR:

Step 1

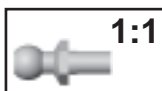

6270, qty 1 ball end



6272, qty 1 dust cover



7337, qty 4 washer



7336, qty 2 servo mount



7336, qty 2 servo mount spacer

9180, qty 1 ea servo horns



1:1 OR 1:1

BASIC, SPORT, TEAM ONLY
6917, qty 4
4-40 x 3/8

FT ONLY
6860*, qty 4
4-40 x 3/8

TOOLS USED

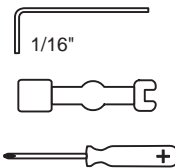

step 1

ASSEMBLE THE SERVO

- Find the appropriate #9180 servo horn for your servo, marked "A" for Airtronics, "F" for Futaba, "J" for JRPropo, and "H" for Hitec. Remove the servo horn from your servo and replace with the #9180 horn, then fasten with the stock mounting screw.
- Install the #6270 ball end into the servo horn. Add the #6272 dust cover.
- Attach the #7336 mounts with the #6917 (6860*) screws and #7337 washers. Add the #7336 spacers if you have an Airtronics servo.

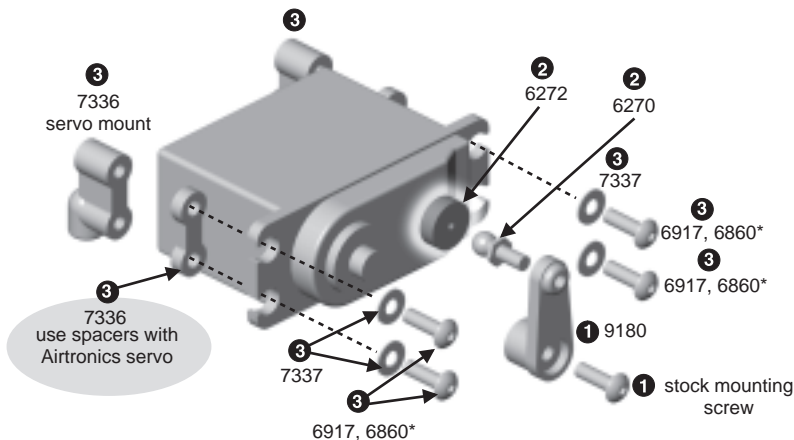

BAG G

REMOVE THESE PARTS FOR:

Step 2

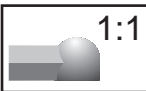

9170, qty 2 servo link cup



9170, qty 1 servo link

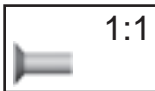

7673, 6933*, qty 2
4-40 x 5/16

TOOLS USED

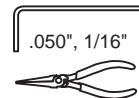

step 2 RIGHT SIDE

MOUNT THE SERVO

- Mount the servo with two #7673 (6933*) screws.
- Assemble the #9170 servo link, matching the length to the true scale drawing.
- Use needle-nose pliers to attach link to ball ends.

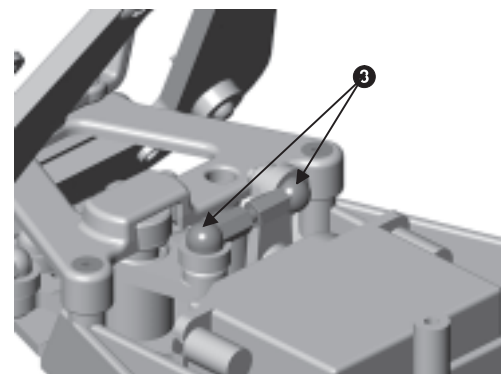
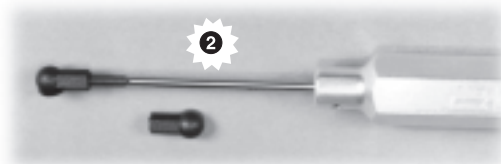
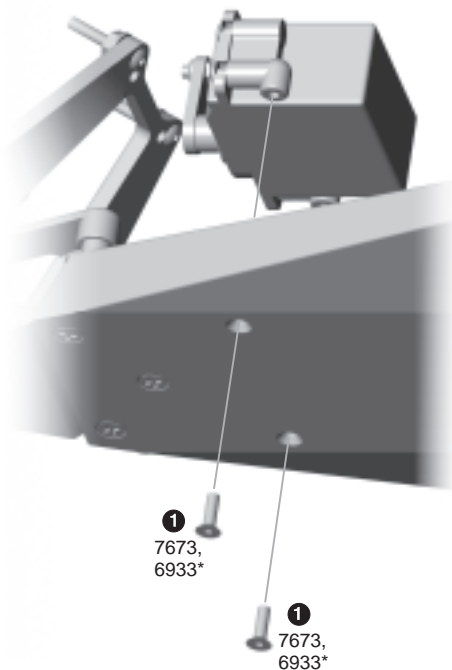
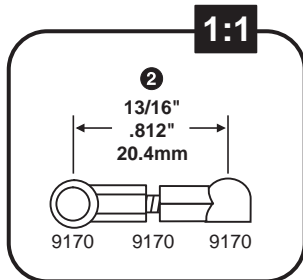

BAG G

REMOVE THESE PARTS FOR:

Step 3



6515, qty 2
3mm x 6mm gold



6936, qty 2
#4 washer



6951, qty 1
4-40 x 1/8 set screw



SPORT ONLY
6681, qty 1
23 tooth pinion gear

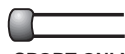

SPORT ONLY
6520, qty 3
.1uf capacitor



SPORT ONLY
6742, qty 1
motor connection plug

SPORT ONLY
580, qty 1
motor

TOOLS USED

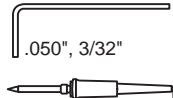

step 3 RIGHT SIDE

INSTALL THE MOTOR

- 1 Attach three capacitors to your motor according to the instructions that came with your motor, if they are not on already. For the **Sport kit**, solder the colored plug wire to a positive tab on the motor and the black wire to a negative tab. For the **Basic, Team & Factory Team kits**, you must buy your own motor, then follow this step.
- 2 Install the #6681 gear with the #6951 set screw going to the flat side of the shaft. For the **Basic, Team & Factory Team kits**, you must buy your own pinion gear. If you use an electronic speed control, see its directions for installing motor capacitors.
- 3 Use two #6515 screws and two #6936 washers to mount the motor as shown so the gears mesh.

SET THE GEAR MESH

- 4 You should be able to rock the spur gear back and forth in the teeth of the pinion gear without making the pinion gear move. If the plastic gear is tight, then loosen the #6515 screws and move the motor away, then try again. A gear mesh that is too tight or too loose will reduce power and damage the gear teeth.

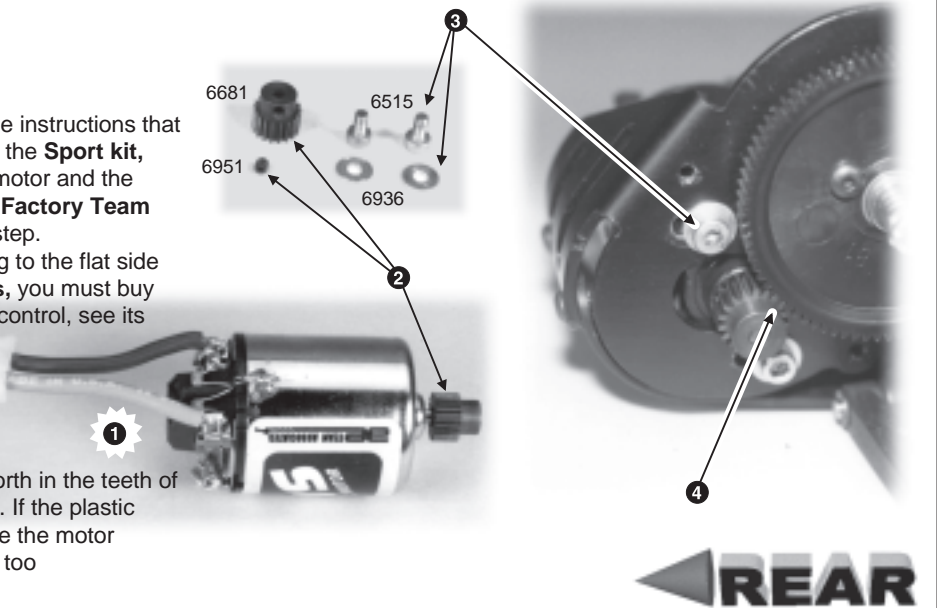

SPORT KIT ONLY

BAG G

REMOVE THESE PARTS FOR:

Sport: steps 4-6

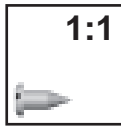

3721, qty 1
2-56
self-tapping



qty 1
#2 washer



6242, qty 1
4-40 locknut

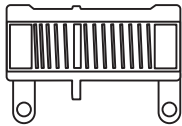

6711, qty 1
throttle resistor

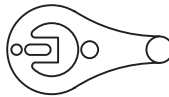

6712, qty 1
throttle wiper arm



6714, qty 1
throttle bypass
mount

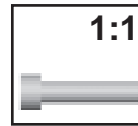

6925, qty 1
4-40 x 1/2

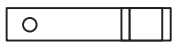

6714, qty 1
throttle bypass tab

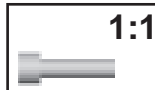

6924, qty 1
4-40 x 3/8



6932, qty 6
4-40 x 5/16



6936, qty 7
#4 washer



7527, qty 2
throttle servo mount



8850, qty 1 ea.
throttle resistor
mounting brackets

TOOLS USED

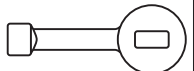

step 4

MOUNTS TO SERVO

- 1 Attach the #7527 mounts to the servo with four #6932 screws and four #6936 washers. Orient your servo output shaft as shown here.

RESISTOR TO SERVO

- 2 Push the #8850 brackets into the #6711 resistor.
- 3 Attach the brackets to the mounts with two #6932 screws and two #6936 washers.

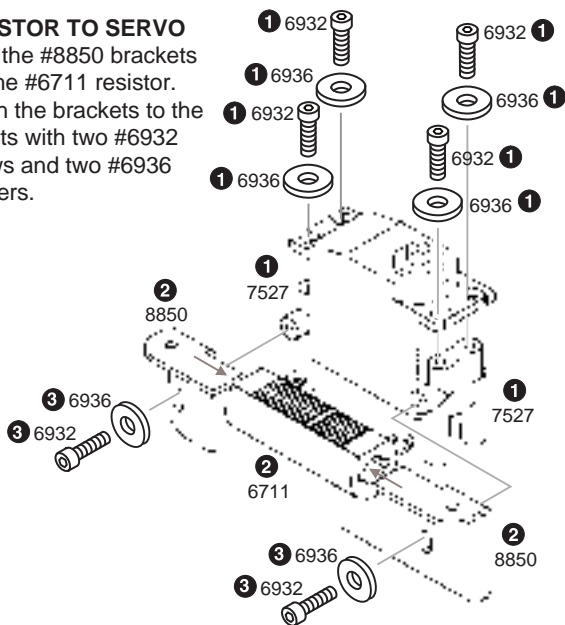

step 5

MODIFY THE SERVO HORN

- 1 There are many servo horns available. The round one is the best one.
- 2 You must modify the horn if you are not using the round one. Trim them so they don't go beyond the #6712 throttle wiper arm outer edge. Also trim so it will clear the resistor.

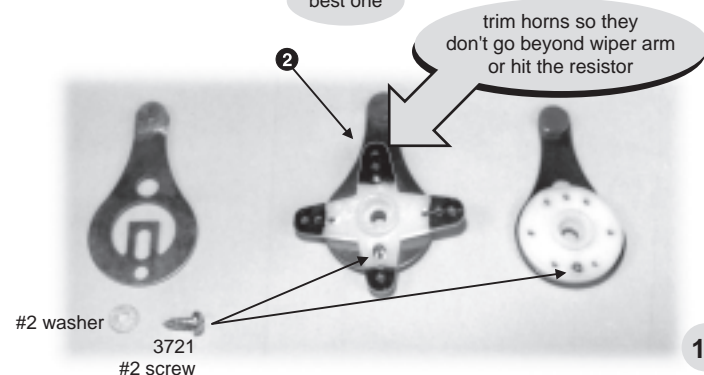

step 6

FINAL RESISTOR/ SERVO ASSEMBLY

- 1 Attach the #6712 arm to the horn with the #3721 screw and #2 washer.
- 2 Mount the arm and horn to the servo with the screw from your servo. Trim the #3721 screw tip if it contacts the servo body.
- 3 Add the #6714 mount using #6925 screw and #6242 locknut.
- 4 Add the #6714 bypass tab to the #6714 mount with a #6924 screw and #6936 washer.

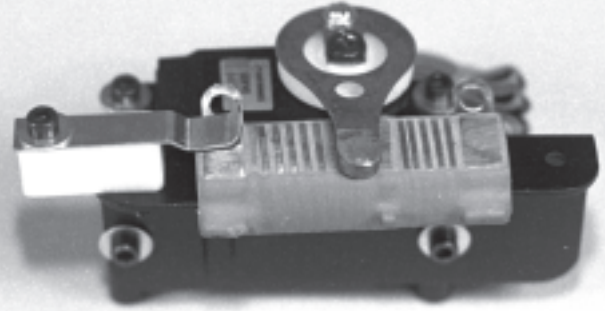
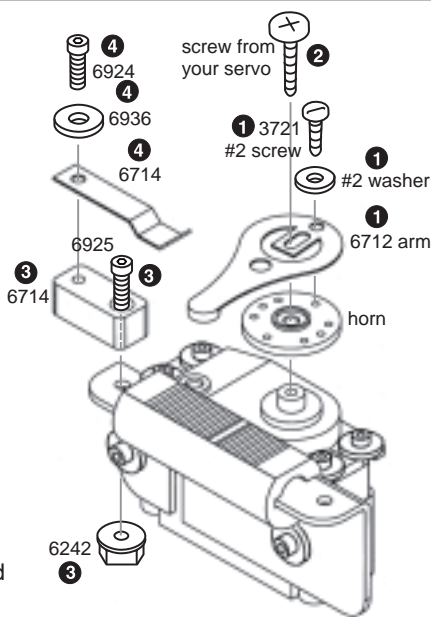

ASSEMBLED THROTTLE ARM AND RESISTOR

SPORT KIT ONLY

BAG G

REMOVE THESE PARTS FOR:

Sport: steps 7-9

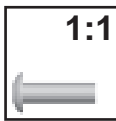

6917, qty 2
4-40 x 3/8

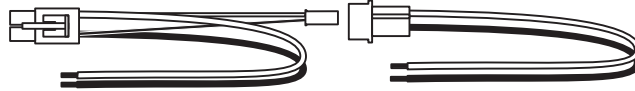

6747, qty 1
battery input harness

6745, qty 1
motor output harness

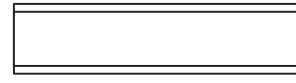

6727, qty 1
servo tape

TOOLS USED

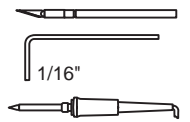

step 7

WIRE THE RESISTOR

- 1 Solder the short red wire between the positive resistor tab and the brass bypass tab.
- 2 Solder the #6745 harness wires to the wiper arm and negative tab on the resistor.
- 3 Solder the #6747 harness to the positive and negative tabs on the resistor.
- 4 Run the wire of the servo attached to the resistor through the battery slot area.

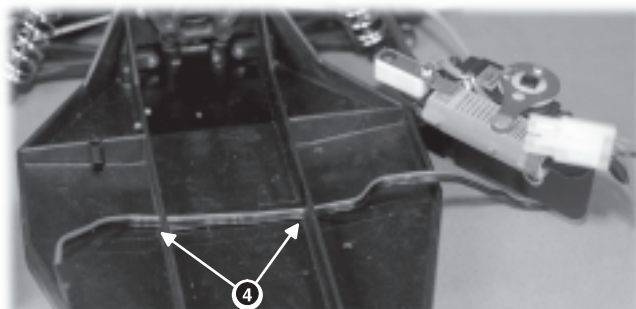
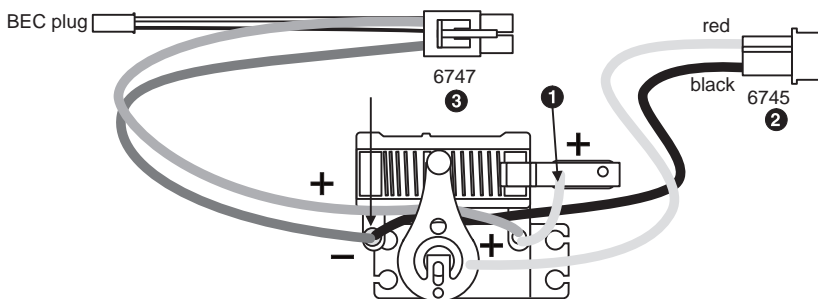

PARTS REMOVED TO IMPROVE CLARITY

20

step 8 LEFT SIDE

SPEED CONTROL TO CHASSIS

- 1 Attach speed control to chassis with two #6917 screws from the bottom.

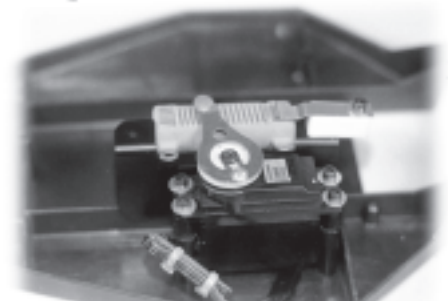
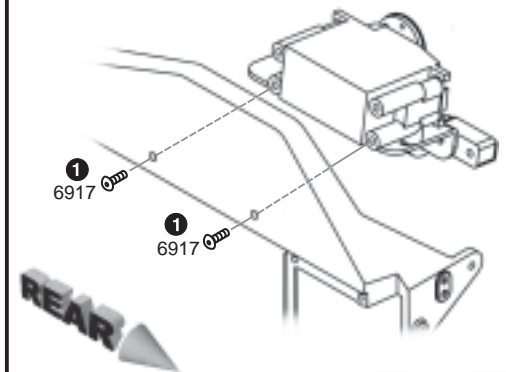

PARTS REMOVED TO IMPROVE CLARITY

REAR

ALL KITS

step 9 LEFT SIDE

RADIO RECEIVER TO CHASSIS

- 1 Cut a piece of servo tape, remove the paper from one side, and attach it to the bottom of your receiver.
- 2 Slip the receiver wire through the built-in chassis antenna mount.
- 3 Remove the paper from the other side and attach to the chassis as shown.
- 4 Plug the small #6747 BEC plug (of step 7) into the receiver's on/off switch.
- 5 Follow the instructions that accompany your radio receiver system.

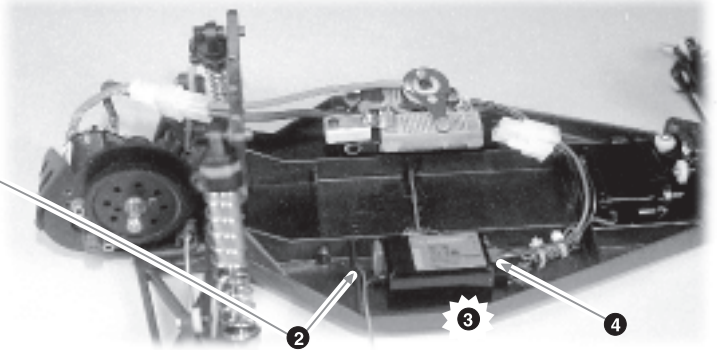
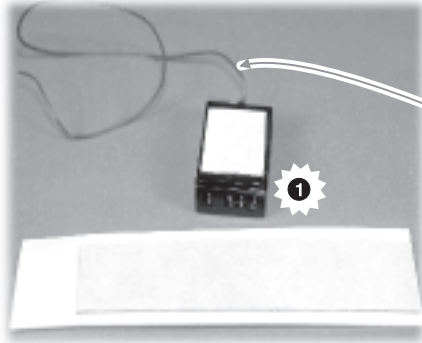

BAG H

REMOVE THESE PARTS FOR:

Steps 1-2



6285, qty 2
4-40 x 1/4



6332, qty 1
body clip



6929, qty 1
4-40 x 3/8



9235, qty 1
foam battery pads



9238, qty 4
battery spacer



9247, qty 1
button

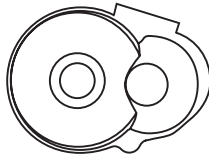

9247, qty 1
gear cover



7333, 7334*, qty 1
battery hold down strap

TOOLS USED

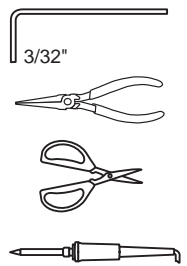

step 1 LEFT SIDE

INSTALLING THE BATTERY PACK

- 1 Install the three #9235 foam battery pads.
- 2 Install the four #9238 foam battery spacers. (The tuning section will show you how to adjust your steering or traction by moving these spacers.)
- 3 Install your battery pack. (See section at right if you need to assemble it first.)
- 4 Thread on the #6929 screw. Aim the body clip hole across the chassis. Add the #7333 (7334*) battery hold down strap. Adjust the screw so the batteries are held tight, but you are still able to push the #6332 body clip through the screw.

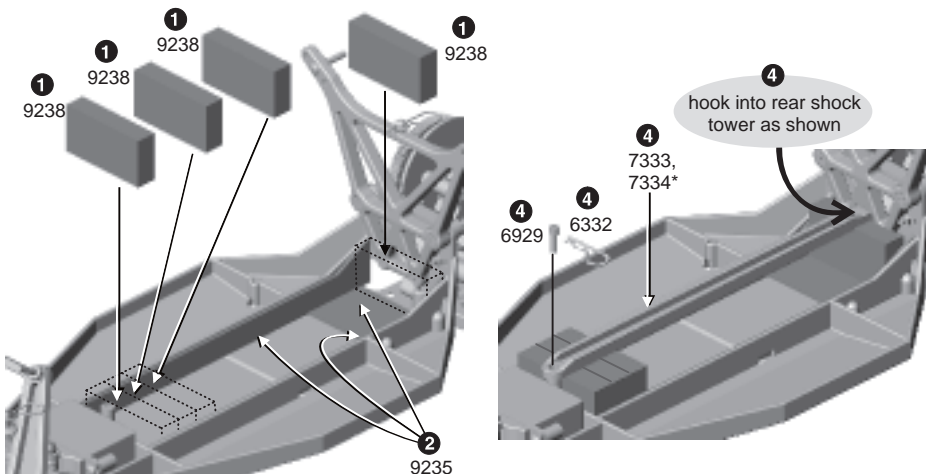

SOLDERING INDIVIDUAL CELLS

Solder connections properly to assemble a battery pack from individual cells.

TIP: Team racers prefer battery bars or braid for sturdier connections. Insulated wire will not allow the pack to fit in the battery slot.

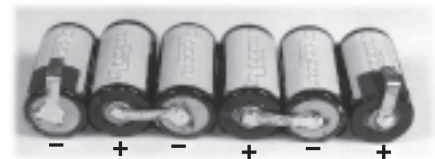
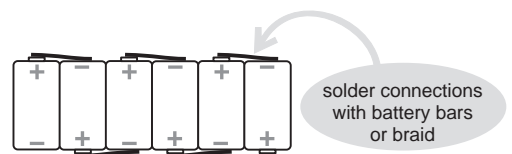

REAR ▶

BATTERY PRODUCTS ARE
NOT INCLUDED IN KIT

step 2 RIGHT SIDE

GEAR COVER

- 1 Trim the #9247 gear cover, cutting out three holes shown. Insert the #9247 insert button into the large hole cut into the gear cover.
- 2 Mount the cover with two #6285 screws.

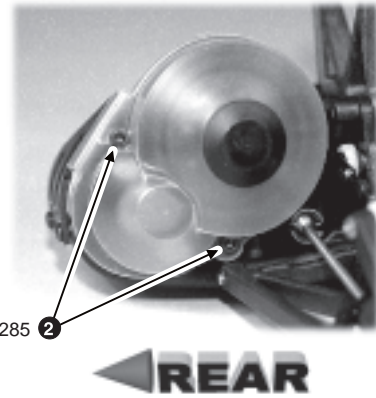
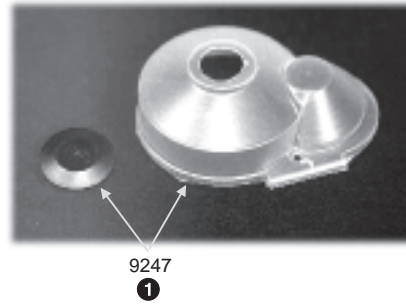

← REAR

BAG H

REMOVE THESE PARTS FOR:

Steps 3-4

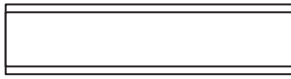

6727, qty 1
servo strip



6338, qty 1
antenna tube cap



6338, qty 1
antenna tube

TOOLS USED



step 3

RADIO AND RECEIVER INSTALLATION

- 1 Install your battery pack as shown. If you need to assemble the battery, see step 1 #5 on page 21.
- 2 Cut a piece of servo tape and use it to attach your ESC and switch where shown.
- 3 Cut a piece of servo tape and use it to attach your receiver where shown.
- 4 Connect the ESC and steering servo to your receiver according to your radio or ESC instructions, then connect the motor to your ESC.

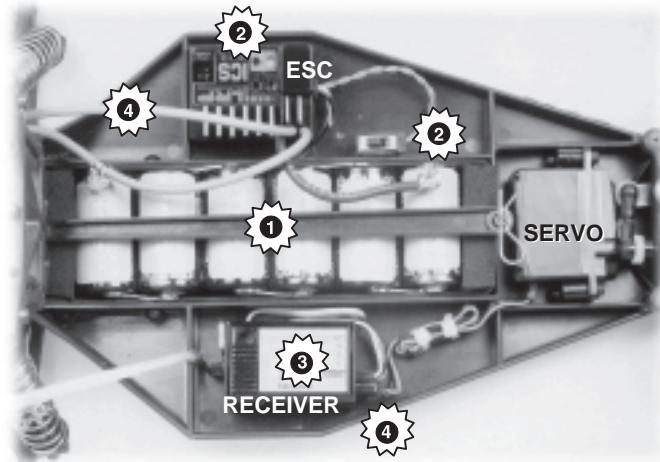

← REAR

step 4

MOUNT THE ANTENNA

- 1 Push your receiver wire through the built-in antenna mount hole.
- 2 Thread the wire through the #6338 antenna and push the antenna firmly into the chassis' antenna mount hole.
- 3 Add the #6338 cap to the other end of the antenna tube.

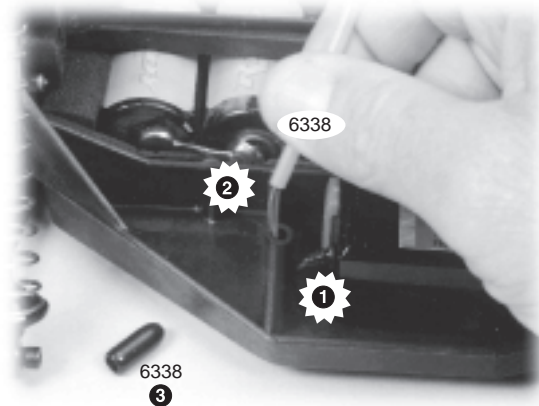

← REAR

BAG H

REMOVE THESE PARTS FOR:

Step 5



6332, qty 2
body clip



6222, qty 2
4-40 nylon nut



6919, qty 2
4-40 x 5/16 screw

TOOLS USED

1/16"



step 5

BODY MOUNTING

- 1 Trim and paint the body. (See painting instructions on page 25 if you have not painted before.) Trim the spoiler from the Chevy body as shown in step 3 below.
- 2 Secure the body to the chassis with three #6332 body clips where shown.

TEAM & FACTORY TEAM



cut openings for wheels

BASIC & SPORT KITS

(spoiler is not included in kit)



cut openings for wheels

TEAM & FACTORY TEAM

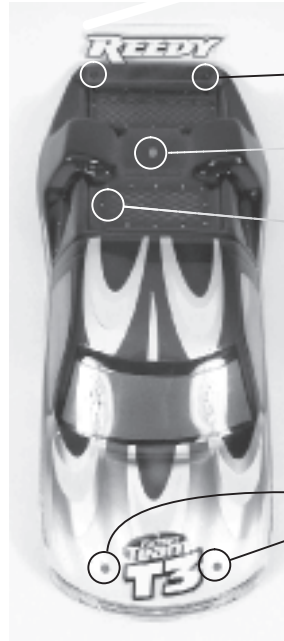

1
cut openings for body

spoiler

body mount

antenna

body mounts

BASIC & SPORT KITS

(spoiler is not included in kit)



2
front body clips

2
rear body clip



SPOILER MOUNTING

(Spoiler is not included in Basic & Sport kits. Order #7185 Spoiler from Associated.)

- 3 Cut spoiler from Chevy body where shown.
- 4 Mount to rear of body using 4-40 nuts and screws.

3
cut from body

4
cut holes for screws in body and spoiler

4
mount spoiler with screws thru top and nuts underneath

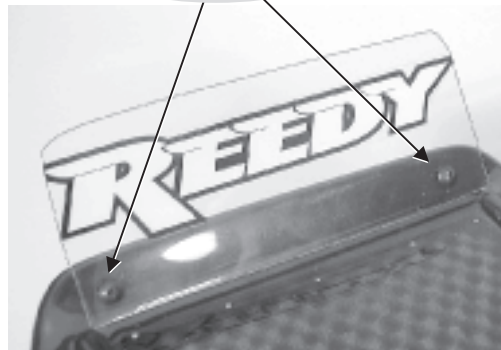
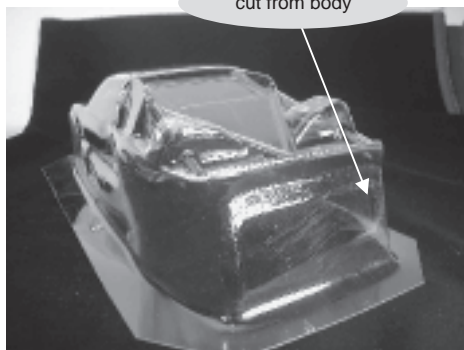

BAG I

REMOVE THESE PARTS FOR:

Steps 1-2



1:1

3438, qty 2
8-32 locknut



1:1

6222, qty 2
4-40/5-40 locknut



1:1

BASIC/SPORT ONLY
6599, qty 4
3/16 x 3/8
unflanged bushing



1:1

TEAM/F.T. ONLY
3977, qty 4
3/16 x 3/8
unflanged ball bearing

TOOLS USED

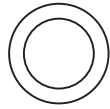
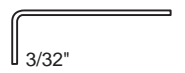

7880, qty 4
foam tire insert

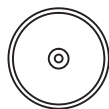

7803, qty pr
1 pc rear wheels

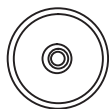

7842, qty pr
1 pc front wheels

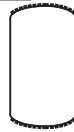

7824, qty 2
rear tire



7877, qty pr
front tire

step 1

REAR WHEELS AND TIRES

- 1 Make a 1/8" hole in the #7803 wheel.
- 2 Make sure the #7880 foam insert is centered in the #7824 tire.
- 3 Install the tire onto the wheel. Glue the tire to the wheel with cyanoacrylic glue in four spots around the tire on both sides. **WARNING: Follow the adhesive instructions for proper use and safety. Wear eye and hand protection.**
- 4 Install the wheel assembly onto the axle, lining up the roll pin with the slot in the wheel. Thread on the #3438 locknut.
- 5 Finish the second rear wheel and tire.

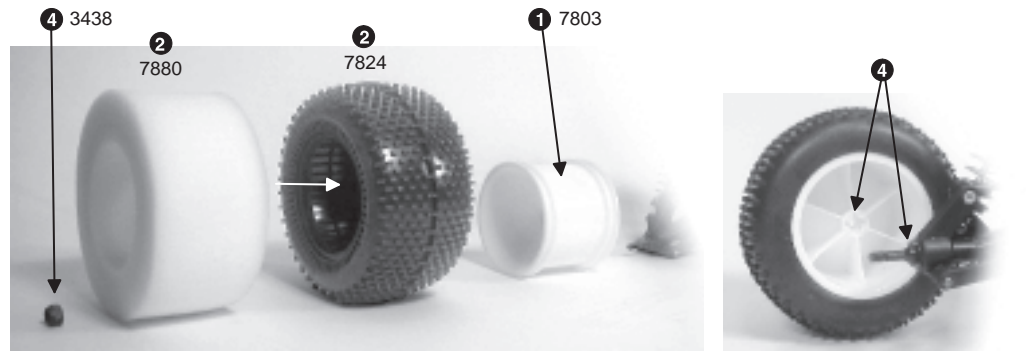

FRONT WHEELS AND TIRES

- 1 Make a 1/8" hole in the #7842 wheel.
- 2 Make sure the #7880 foam insert is centered in the #7877 tire.
- 3 Install the tire onto the wheel. Glue the tire to the wheel with cyanoacrylic glue in four spots around the tire on both sides.
- 4 Insert the #3977 bearings or #6599 bushings into both sides of the front wheel.
- 5 Install the wheel assembly onto the axle. Thread on the #6222 locknut.
- 6 Finish the second front wheel and tire.

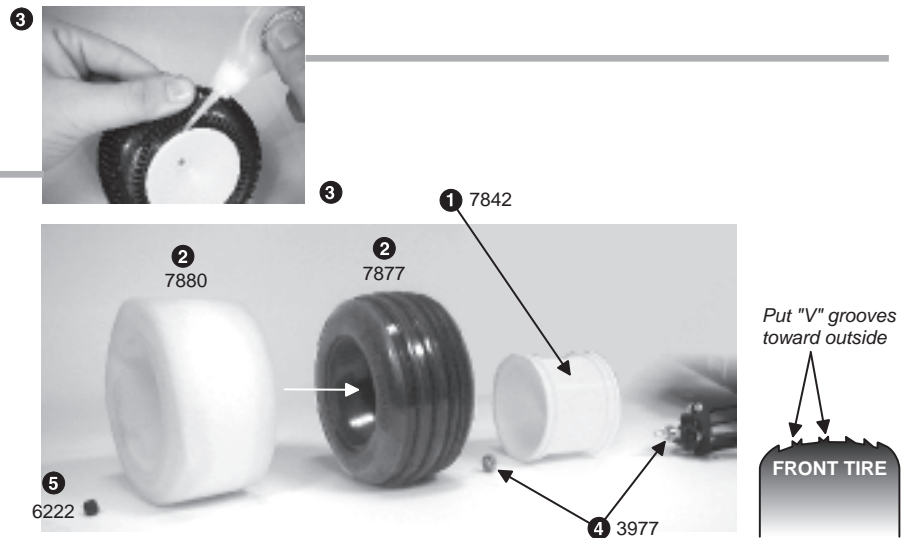

POWER 20 MOTOR MAINTENANCE

Between runs let your motor cool and inspect it for dirt or other deposits. Make sure not to overheat the motor or this will cause serious damage. After inspection, if your motor is dirty, remove it from your truck and follow these instructions.

- 1 One recommended method of cleaning is to spray motor cleaner (electric contact cleaner) directly in through the can area onto the brushes and commutator area.
- 2 After spraying, run the motor for approximately 15 seconds.
- 3 Disconnect the motor and spray it again, making sure the spray comes out clear and clean.
- 4 After completing the cleaning, apply a small amount of lightweight oil (such as 3-in-1™ brand) to each bushing for lubrication. Be careful not to apply too much oil, for this will pick up dirt and damage the commutator and brushes.

Use the recommended gearing for this motor, 18 tooth pinion gear with 87 tooth spur gear.

Reinstall the motor according to page 19.



Spray the motor directly through the can onto the brushes and commutator.



Apply a small amount of lightweight oil to each bushing for lubrication.