

# 1:10 SCALE OVAL CAR KIT

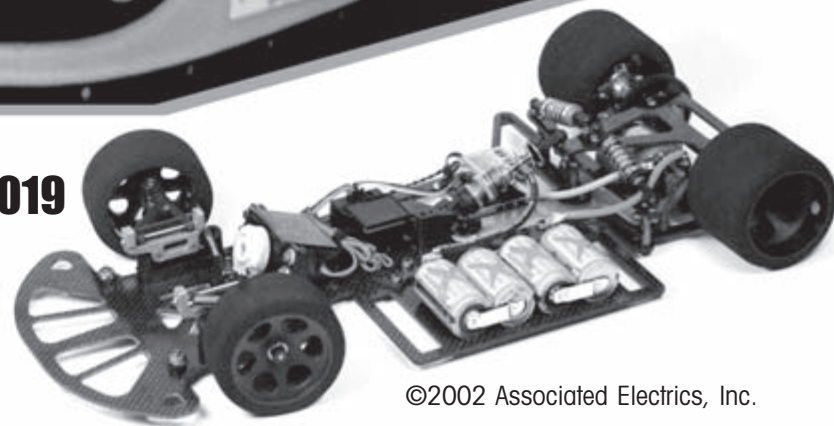

INSTRUCTION MANUAL FOR KIT #8019



# BEFORE BUILDING

## OPEN THE BAGS IN ORDER

The assembly is arranged so that you will open and finish that bag before you go on to the next bag. **Sometimes you will have parts remaining at the end of a bag. These will become part of the next bag.** Some bags may have a large amount of small parts. To make it easier to find the parts, we recommend using a partitioned paper plate for spreading out the parts so they will be easier to find.

## MANUAL FORMAT

The following explains the format of these instructions.

**The beginning of each section indicates:**

- 1 Which bag to open ("**BAG A**").
- 2 Which parts you will use for those steps. Remove only the parts shown. "**1:1**" indicates an actual size drawing; place your part on top and compare it so it does not get confused with a similar part.
- 3 Which tools you should have handy for that section.

**4** In some drawings, the word "**REAR**" with an arrow indicates which direction is the rear of the car to help keep you oriented.

**5** The instructions in each step are ordered in the order you complete them, so read the words AND follow the pictures. The numbers in circles are also in the drawing to help you locate them faster.

**6** When we refer to left and right sides of the car, we are referring to the driver's point of view inside the car.

## SUPPLEMENTAL SHEETS

We are constantly developing new parts to improve our kits. These changes, if any, will be noted in supplementary sheets located in a parts bag or inside the kit box. Check the kit box before you start and each bag as it is opened. When a supplement is found, attach it to the appropriate section of the manual.

# TOOLS

## KIT TOOLS SUPPLIED

- 1 Allen wrenches, .050", 1/16", 3/32"
- 2 shock tool
- 3 other tools
- 4 metal turnbuckle wrench

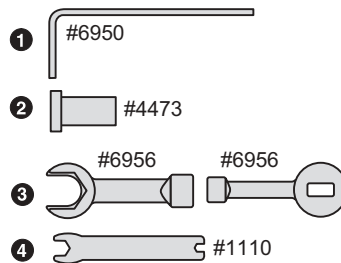

## EXTRA TOOLS NEEDED

- 1 Phillips screwdrivers #2
- 2 needlenose pliers
- 3 soldering iron (40-50 watts) and a small amount of Rosin core solder. Pencil-type soldering iron is better than the gun type. **DANGER! Tip is HOT!**
- 4 Locking adhesive (#1596 or equivalent)
- 5 hobby knife **WARNING! This knife cuts plastic and fingers with equal ease, so be careful.**
- 6 precision ruler
- 7 file
- 8 hand drill with 3/32" (or #43) drill bit
- 9 electrician's tape
- 10 strapping tape

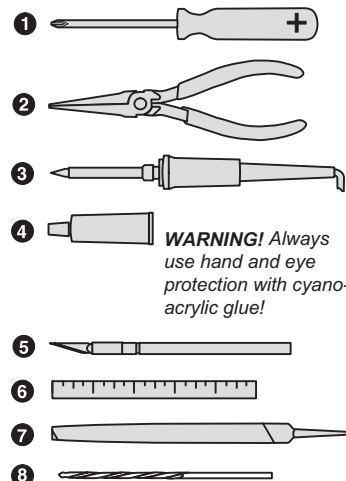

**WARNING!** Always use hand and eye protection with cyano-acrylic glue!

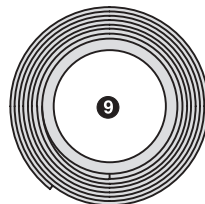
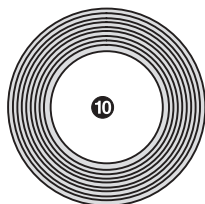

## HELPFUL TOOLS (NOT REQUIRED)

- 1 Allen drivers (straight Allen wrenches with hex shaped handles) such as the following made by Associated:

- #6957 .050" Allen wrench
- #6958 1/16" Allen wrench
- #6960 3/32" Allen wrench
- #6961 2.5mm Allen wrench

- 2 Vernier calipers
- 3 Hobby scissors
- 4 Nut drivers (screwdriver-handled hex socket tools) such as the following from Associated:
  - 3/16" nut driver
  - 1/4" nut driver
  - 11/32" nut driver

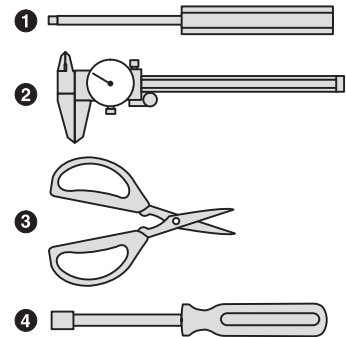

**WARNING!** Do not use a power screwdriver to install screws into nylon, plastic, or composite materials. The fast rotation speed can heat up the screws being installed. They can then break or strip the threads during installation.

## ITEMS NEEDED TO OPERATE YOUR CAR

- 1 R/C two channel surface frequency radio system.
- 2 \*Battery pack (6 cell).
- 3 Battery charger (we recommend a peak detection charger).
- 4 \*Electronic speed control.
- 5 \*R/C electric motor.
- 6 \*Pinion gear, size to be determined by type and wind of motor you will be using.
- 7 1:10 scale Lexan body and wing.
- 8 \*1:10 scale on road wheels, and foam or capped tires (capped tires not available from Associated).

\* Available from Associated. See your 10L catalog.

### File the battery tray

Use your file to bevel the slots on the top side of the #8492 battery tray so the edges won't cut through the battery cell wrap. Then file all the outside edges of the tray. Lightly sand all edges.

### Warning!

Graphite dust can be harmful to your health. File in a well ventilated area. Then wash the tray with water and dry with a paper towel. Wash your hands afterwards with cold water and soap.

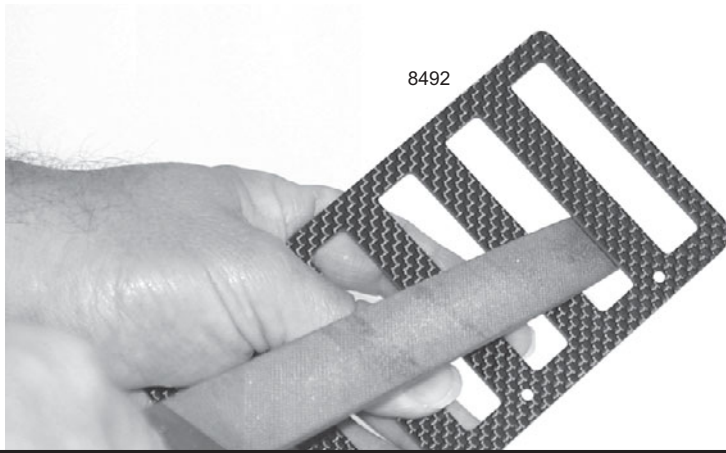

8492

**BAG A**  
 REMOVE THESE PARTS FOR:  
 8019: step 1



8405, qty 2  
upper suspension arm



8505, qty 2  
adjustable caster block



8419, qty 2  
lower suspension arm

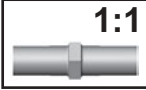

1:1  
8415, qty 2  
upper suspension arm tum buckle



1:1  
8411, qty 2  
upper suspension arm eyelet

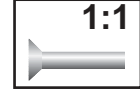

1:1  
8409, qty 4  
4-40 x 1/2" shoulder screw, blue aluminum



1:1  
8417, qty 4  
pivot ball

**TOOLS USED**

### step 1 LEFT SIDE

#### Assemble upper suspension arm

- 1 Assemble parts #8405, 8415 and 8411.

#### Attach upper arm mount to lower arm

- 2 Attach #8505 adjustable mount (caster block) to the #8419 lower suspension arm using two #8409 screws. **WARNING!** Screws are difficult to screw in. Turn carefully so you do not strip out the head.

#### Installing upper and lower pivot balls

- 3 (Not shown.) Before popping in the #8417 pivot balls, make sure there are no burrs inside the pivot ball holes.
- 4 Pop the #8417 pivot balls into the suspension arms as shown. Make sure that the shoulders of the pivot balls in the lower suspension arms are facing upward and the upper pivot balls have the shoulder facing downward.
- 5 (Not shown.) Now assemble the right side.

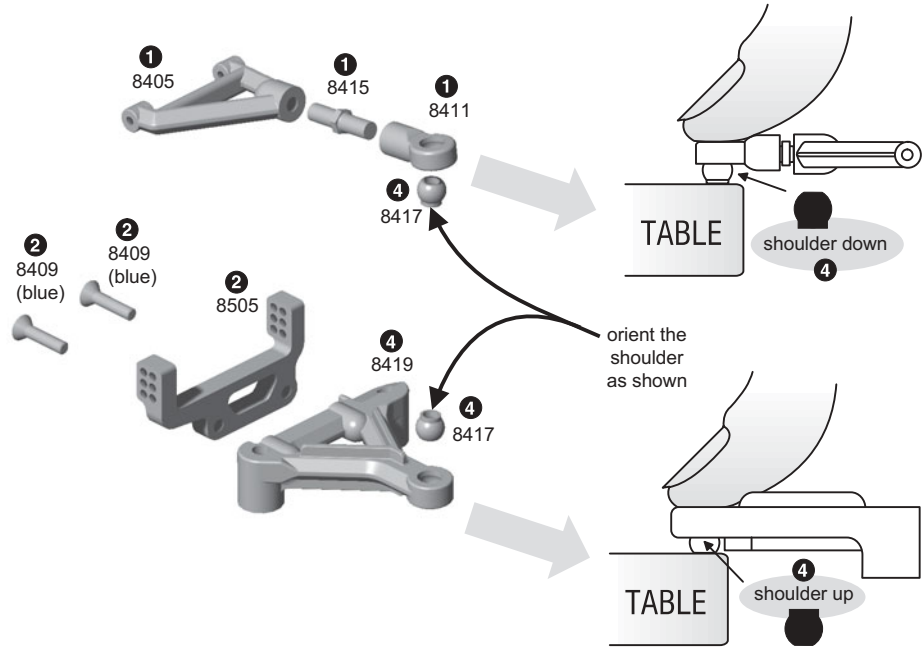

**BAG A**  
 REMOVE THESE PARTS FOR:  
 8019: steps 2-3

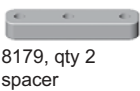

8179, qty 2  
spacer



1:1  
8439, qty 4  
8-32 x 5/8 blue aluminum

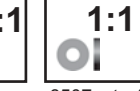

1:1  
8507, qty 4  
caster shim



1:1  
6951, qty 2  
set screw



1:1  
8507, qty 2  
pin E-clip



1:1  
6299, qty 4  
E-clip



1:1  
6937, qty 2  
4-40 blue nut

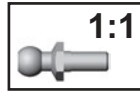

1:1  
4448, qty 2  
ball end blue aluminum



1:1  
8429, qty 2  
spring, .020



1:1  
8425, qty 10  
kingpin shim



8441, qty 2  
inline steering block



8506, qty 2  
pin



8423, qty 2  
kingpin



1:1  
8443B, qty 2  
inline axle



8487, qty 1  
chassis



1:1  
8423, qty 2  
kingpin

**TOOLS USED**

locking adhesive 3

## step 2 LEFT SIDE

### Upper arm to the suspension arm

- 1 Mount the upper arm assembly to the suspension mount as shown, using the #8506 pins and #8507 caster shims. Start with the lower outer position on the adjustable arm mount. Attach the #8507 small E-clip to the pin.

### Final front assembly

- 2 Slide in and center #8443B axle in the #8441 steering block. Start threading the #6951 set screw into the back of the axle, but do not tighten it yet.
- 3 Screw the #4448 ball end into the back hole in on the steering block. Attach the #6937 nut to the ball end.
- 4 Place one #6299 E-clip on the bottom of the #8423 kingpin then slide on the #8429 spring.
- 5 Slide the kingpin through the bottom of the suspension arm and up through the steering block.
- 6 Place one #8425 kingpin shim over the kingpin.
- 7 Now push the upper arm over the kingpin. Place four #8425 shims over the kingpin and secure it with a #6299 E-clip.
- 8 (Not shown.) Do the other side.

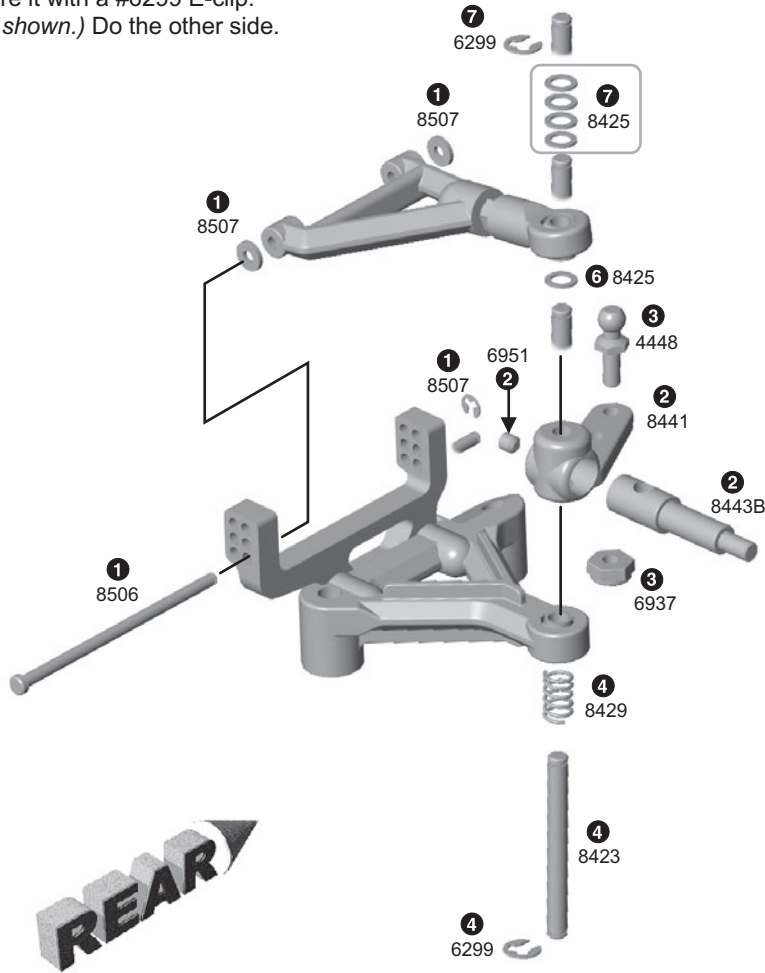

## step 3 LEFT SIDE

### Suspension arms to chassis

Place the #8179 spacer between the suspension arms and #8487 chassis, using the holes that are furthest forward, then bolt on with two #8439 screws from underneath the chassis.

Do the other side.

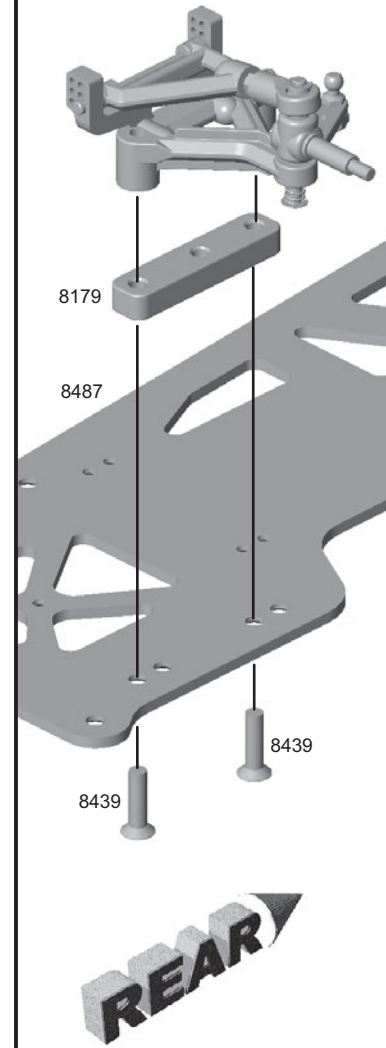

## BAG B

REMOVE THESE PARTS FOR:

8019: step 1

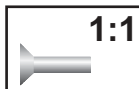

6292, qty 5  
4-40 x 3/8



6937, qty 5  
4-40 blue nut



8490, qty 1  
tray bracket



8492, qty 1  
6 cell battery tray

## TOOLS USED

1/16"

# step 1

- 1 Attach #8490 tray bracket to the chassis with two #6292 screws and two #6937 nuts.
- 2 Attach the #8492 tray to the tray bracket with three #6292 screws and three #6937 nuts.

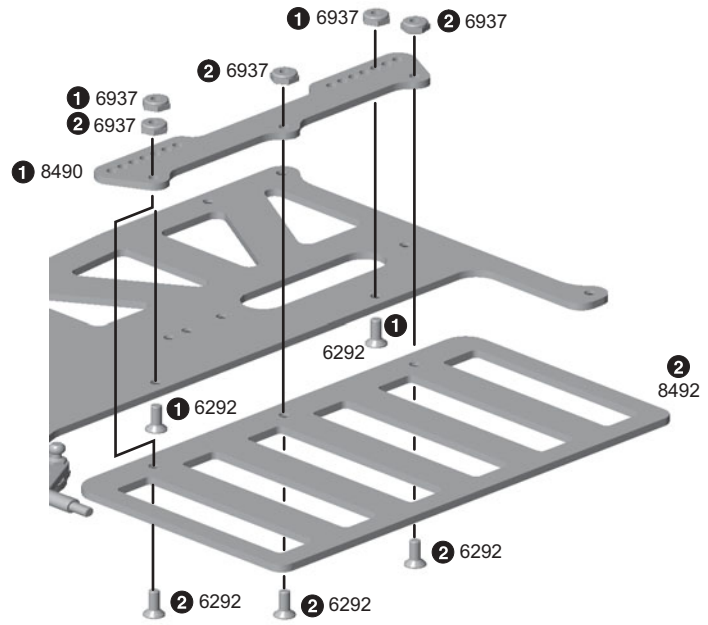

# BAG C

REMOVE THESE PARTS FOR:  
8019: steps 1-3

4335, qty 2 ea pivot socket, upper and lower	4334, qty 8 2-56 x 5/16	4336, qty 2 pivot ball steel	6292, qty 2 4-40 x 3/8 steel	4526, qty 2 T-bar spacer molded plastic	7260, qty 1 4-40 nut	6934, qty 3 4-40 x 3/8 blue alum.	7673, qty 2 4-40 x 5/16 steel
4541, qty 1 left rear bulkhead	4537B, qty 1 motor bulkhead	8461, qty 1 lower pod plate	8191, qty 1 T-bar, .075"	4519, qty 1 4-40 x 9/16	6937, qty 2 4-40 blue locknut		

### TOOLS USED

.050", 1/16"

# step 1

## T-Bar assembly

- 1 Assemble the #4335 sockets and #4336 pivot balls.
- 2 Secure the T-bar pivot assemblies to the #8191 T-bar using four #4334 screws as shown, install both at the same side on the T-bar.

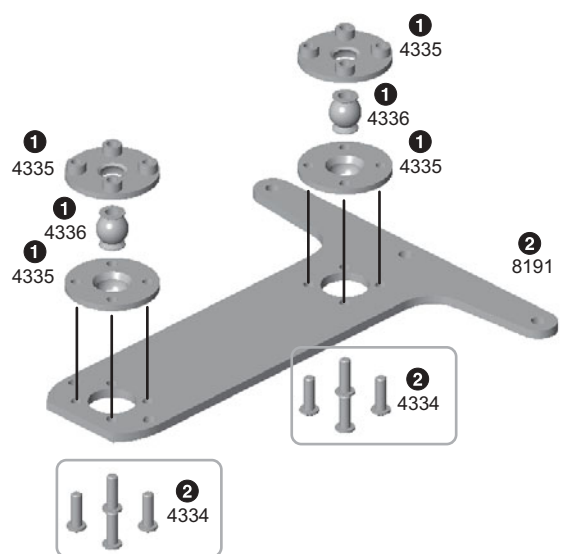

# step 2

## Rear pod assembly

- 1 Bolt the #4541 left bulkhead to the #8461 lower pod plate with three #6934 screws.
- 2 Bolt the aluminum #4537B motor bulkhead to the pod plate with two #7673 screws.
- 3 Attach the T-bar assembly to the lower pod with two #6292 screws, two #4526 spacers and two #6937 nuts. The spacers go between the T-bar and the lower pod plate.

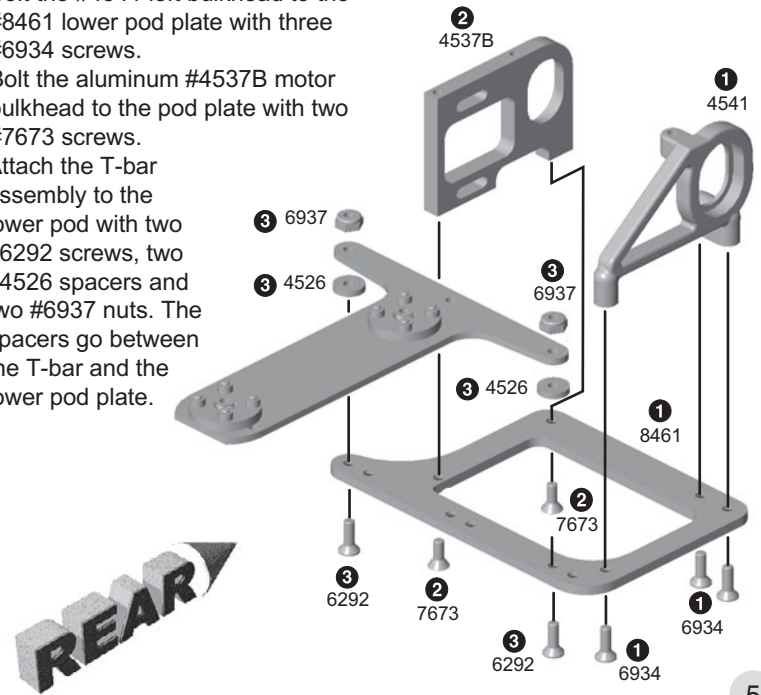



# step 4 LEFT SIDE





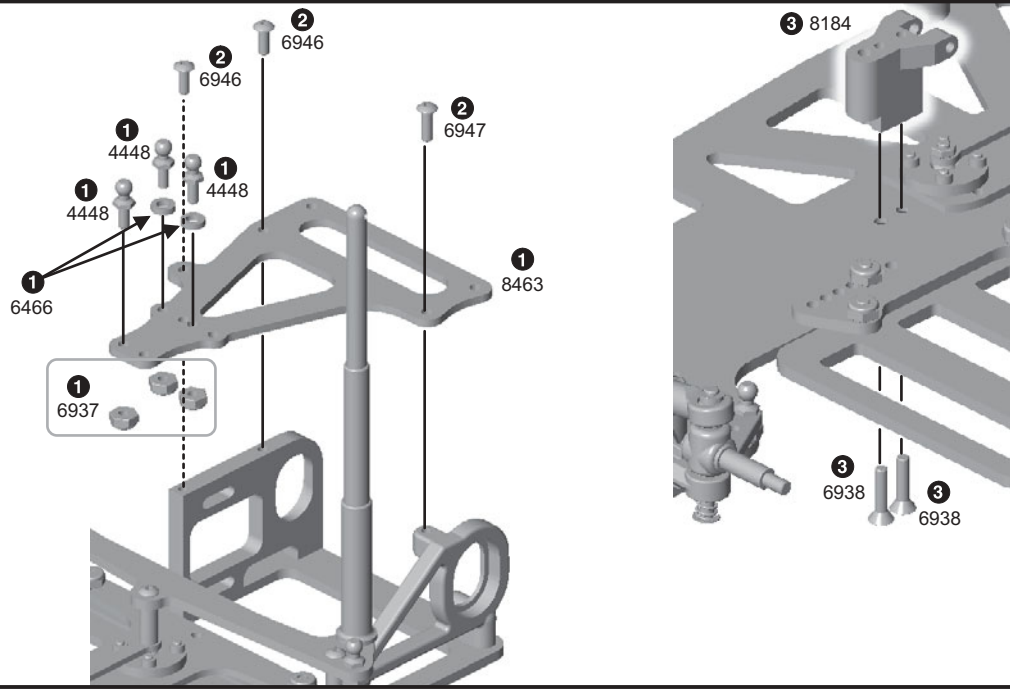

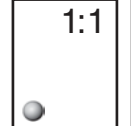
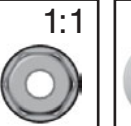

## Top plate assembly

- 1 Install the three #4448 ball ends, two #6466 spacers to the #8463 top plate with three #6937 nuts. Be sure to use the correct set of mounting holes as shown.
- 2 Mount the top plate to the rear pod with two #6946 screws into the motor bulkhead and one #6947 screw into the plastic bulkhead.
- 3 Remove the attached shock cap bushing from the #8184 shock mount and set it aside for latter. Attach the #8184 shock mount to the chassis with two #6938 screws.



# BAG D

REMOVE THESE PARTS FOR:  
8019: steps 1-4

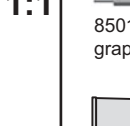
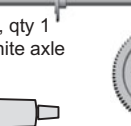
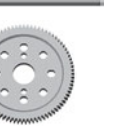
 1:1 897, qty 5 1/4 x 3/8 flanged bearing	 1:1 6626, qty 8 1/8" diff ball	 1:1 4185, qty 1 8-32 locknut nylon	 1:1 8213, qty 3 Belleville washer	 1:1 6924, qty 2 4-40 x 3/8	 1:1 8321B qty 1 rear axle spacer	 1:1 8503, qty 1 left wheel hub
 4349, qty 2 ride height adjuster, #1 UP	 8213B, qty 1 diff thrust cone	 8502, qty 1 right hand diff/ long wheel hub	 1:1 8504, qty 2 diff D ring	 8501, qty 1 graphite axle	 6636, qty 1 silicone grease	 8282, qty 1 diff gear 81 tooth, 48 pitch

## TOOLS USED

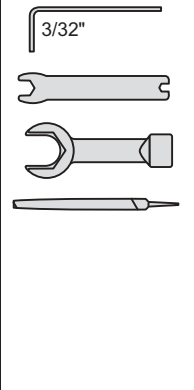

# step 1

## Rear diff assembly

- 1 Hold the #8501 pro axle upright and slide on one #8504 D-ring over the axle and onto the axle flange, making sure to line up the flats on the diff ring and flange.
- 2 Slide one #897 bearing onto the axle with the flange side facing down on the bearing.
- 3 Add #6636 silicone grease to the ball holes on the #8282 81T spur gear.
- 4 Push the eight #6626 balls into the holes.
- 5 Slide the gear with the balls onto the axle, making sure to center the gear on the bearing.

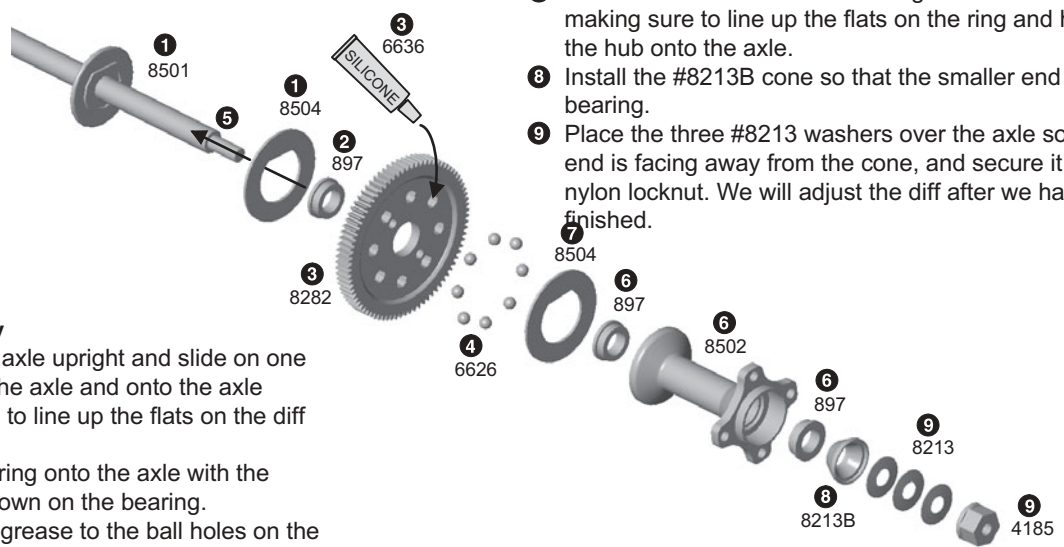

- 6 Insert the two #897 bearings into both ends of the #8502 diff hub.
- 7 Place the second #8504 drive ring onto the #8502 drive hub, making sure to line up the flats on the ring and hub, then slide the hub onto the axle.
- 8 Install the #8213B cone so that the smaller end is facing the bearing.
- 9 Place the three #8213 washers over the axle so that the smaller end is facing away from the cone, and secure it with a #4185 nylon locknut. We will adjust the diff after we have the car finished.

# step 2

## Installing the axle assembly

- Find the #4349 adjusters that have the #1 on them, and insert them into the rear pod. Insert two #897 bearings into the ride height adjusters as shown.
- Slide the complete axle assembly through the motor bulkhead until it extends through the plastic bulkhead on the other side. Slide on the #8321B axle spacer on the left side, the shoulder side of the spacer should be facing the bearing.
- Install the #8503 left wheel hub onto the rear axle. Thread the two #6924 screw into the hub.

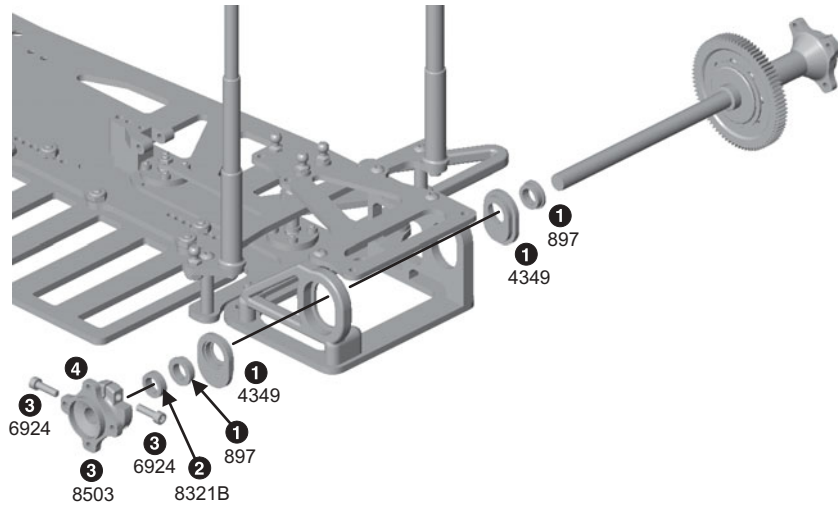

## Setting the axle play

- Make sure there is a slight (less than 1/64" or .015") amount of axle endplay. Now tighten the hub screws a little at a time till both screws are equally tightened. DO NOT fully tighten down one screw at a time.

**Note:** This kit comes standard with a full offset pod setup. When using a full 2" left rear tire you will need to trim the inside of the tire to keep it from hitting the lower pod plate.

# BAG E

REMOVE THESE PARTS FOR:

8019: steps 1-4

<p>1:1 5407, qty 2 red O-ring</p>	<p>1:1 6299, qty 2 E-clip</p>	<p>1:1 7230, qty 1 ball cup</p>	<p>1:1 8456, qty 1 VC foam</p>	<p>3963, qty 1 shock body</p>	<p>6418, qty 1 .71 shock shaft Unobtainium</p>
<p>1:1 6465, qty 1 shock piston #1</p>	<p>1:1 6469, qty 1 large O-ring</p>	<p>5422, qty 1 30 wt silicone oil</p>	<p>8456, qty 1 VC bobbin</p>		

# TOOLS USED

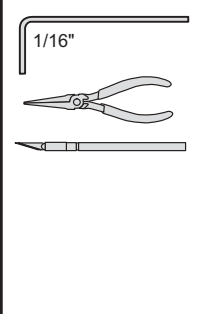

# step 1

## Trim shock piston

- Burrs interfere with smooth shock action within the shock body. To remove from tree without creating burrs, twist up, not down. Remove one #6465 shock piston #1.
- (Not shown.) Remove remaining burrs carefully with a hobby knife.

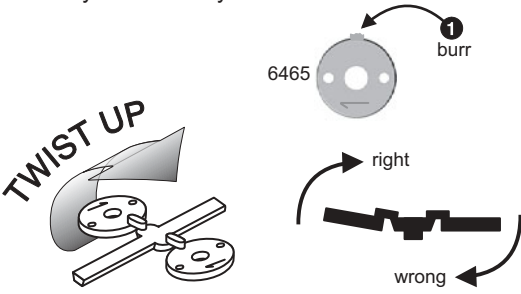

# step 2

## VC foam and bobbin

Soak the #8456 VC foam with #5422 shock oil and install it onto the #8456 VC bobbin.

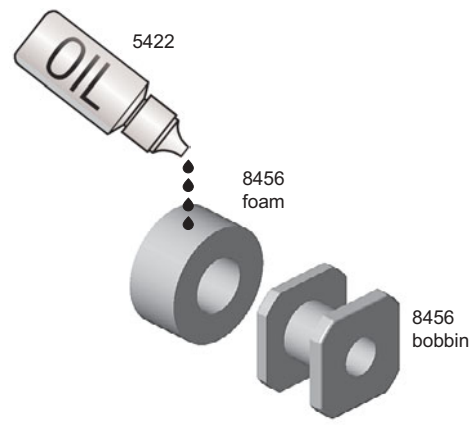

# step 3

- 1 Install the #6469 O-ring over the threads of the #3963 shock body.
- 2 Install a #6299 E-clip and #6465 (#1) piston onto the end of the #6418 shaft. Add a second E-clip.
- 3 Slide the assembled #8456 VC foam/bobbin over the #6418 shaft and then two #5407 O-rings. Place a couple of drops of #5422 oil on the O-ring.
- 4 Insert the assembly into the shock body and pull the shaft through firmly to seat the VC bobbin at the base of the shock.
- 5 Screw the #7230 ball cup onto the end of the shock shaft while holding the shaft with needle nose pliers next to the threads.

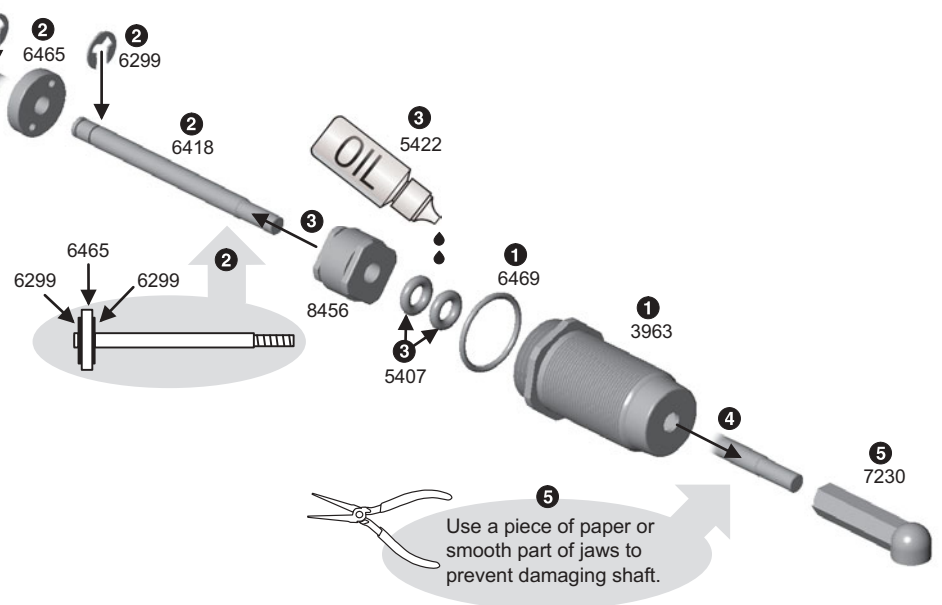

Use a piece of paper or smooth part of jaws to prevent damaging shaft.

# BAG E

REMOVE THESE PARTS FOR:  
8019 steps 4-6

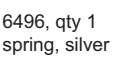
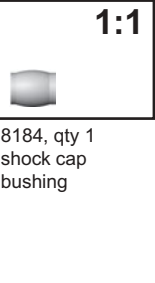
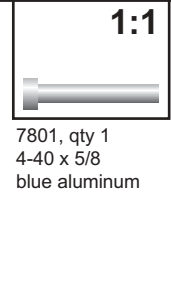
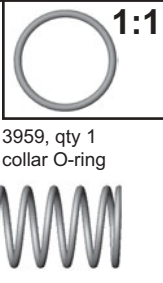

# TOOLS USED

3/32"  
Needle nose pliers

# step 4

- 1 Holding the shock upright, fill with oil to the top of the body.



- 2 Slowly move the shaft up and down several times to allow air bubbles to escape to the top.

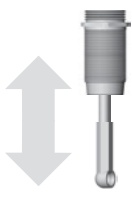

- 3 Refill with oil to the top of the body.



- 4 Push the shaft up until the piston is level with the top of the body. The oil will bulge up above the shock body.



- 5 Fill The #6428 shock cap about halfway with oil and install onto the body. Try to retain as much oil as possible during assembly. The shaft will extend out as you tighten the cap down.

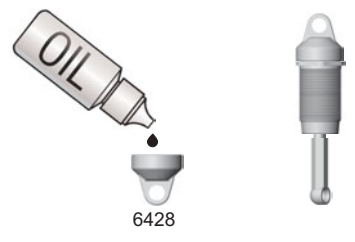

# step 5

- 1 Slide the #3959 collar O-ring into the groove of the #3963 shock collar.
- 2 Add a drop of #5422 oil to the #3963 collar threads and O-ring. Thread the collar onto the shock body, making sure the shoulder on the collar is facing away from the cap.
- 3 Slide on the #6496 spring, and then compress the spring to add the #6475 spring cup.
- 4 Pick up the small #8184 bushing you had removed from the shock mount and push it into the shock cap.

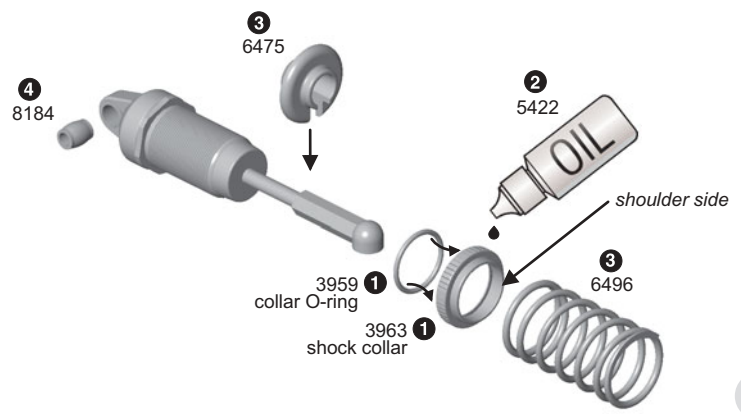

# step 6

## MOUNT THE SHOCK

- 1 Install the shock cap & bushing into the antenna mount and secure it using a #7801 screw.
- 2 Snap the ball cup onto the ball end as shown.

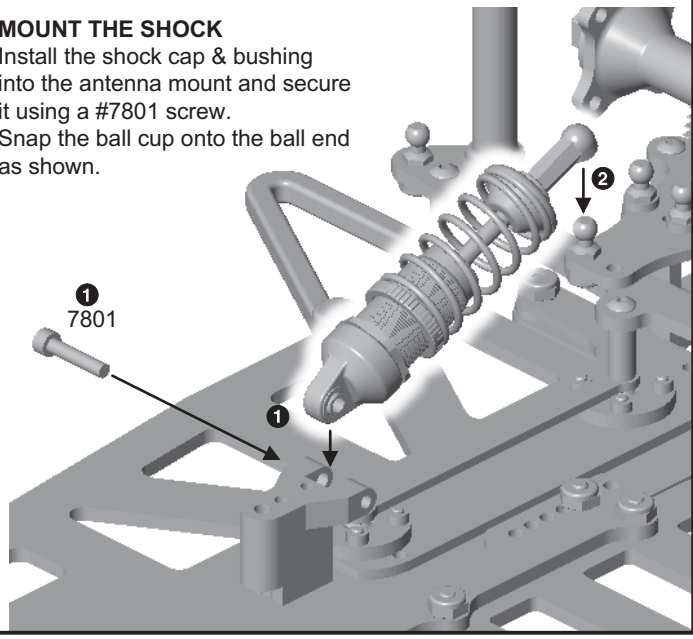





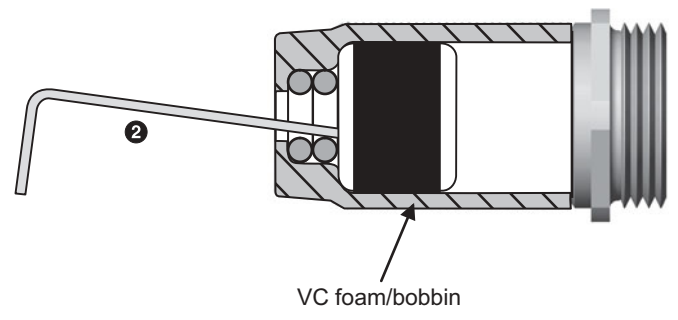



# DISASSEMBLY of VCS shock seal assembly

- 1 (Not shown.) To take out the VC foam/bobbin, unscrew the ball cup and shock cap, and push the shock shaft out.
- 2 Push your Allen wrench tip into the shock bottom and push the bobbin out, as shown. The O-rings should just fall out by themselves.

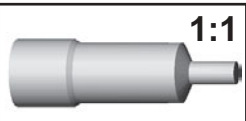

# BAG E

REMOVE THESE PARTS FOR:  
8019: steps 7-10

1:1 	1:1 	1:1 	1:1 	1:1 	1:1 
#4473, qty 2 black VC foam	#4473, qty 2 VC housing	#4472, qty 2 shock shaft and piston	#4473, qty 2 large washer	#4473, qty 2 red O-ring	#4473, qty 2 small washer
1:1 	1:1 	 5422, qty 1 30 wt silicone oil			
#4471B, qty 2 micro shock body	#4473, qty 2 star clip				

# TOOLS USED

1:1



#4473, qty 1  
assembly tool

# VCS MICRO SHOCK

Team Associated's VCS™ (Volume Compensating System) Micro Shock was developed as a higher-volume, lightweight, constant-travel shock to fit on most road/oval 1:10 and 1:12 cars, and provides consistently smooth, superior dampening without the need for frequent rebuilds.

The VCS™ Micro Shock body is precision-machined from aircraft-quality aluminum, and is externally threaded for convenient spring pre-load adjustments. Internally, the shock utilizes Associated's exclusive VCS™ volume compensating system, 7075 aluminum shock piston, molded Teflon components, and a precision-ground, case-hardened steel shock shaft which is extremely resistant to bending.

# step 7

- 1 (Not shown.) Remove the plastic #4473 VC housing from the parts tree.
- 2 Soak the #4473 VC foam with your #5422 shock oil.
- 3 Push the foam into the housing.

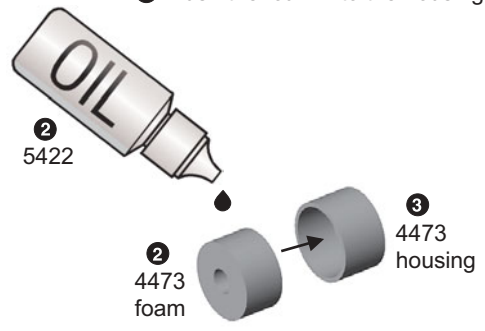

## step 8

- 1 Fill #4471B shock body with oil up to the upper groove.
- 2 Insert #4472 shaft/piston all the way to the bottom

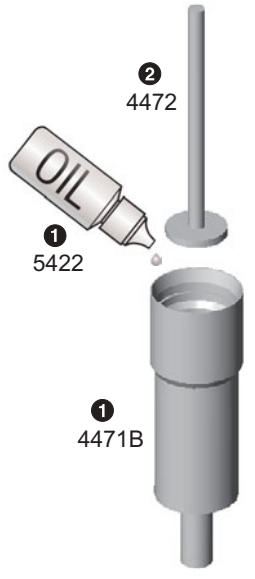

## step 9

- 1 Remove the small and large #4473 washers from the parts tree. Remove any flash from the washers.
- 2 Slide the VC housing with foam onto the shaft, housing first (so foam is still seen through the body opening).
- 3 Slide on the following in this order: smaller washer, red O-ring, larger washer, then the star-shaped clip.

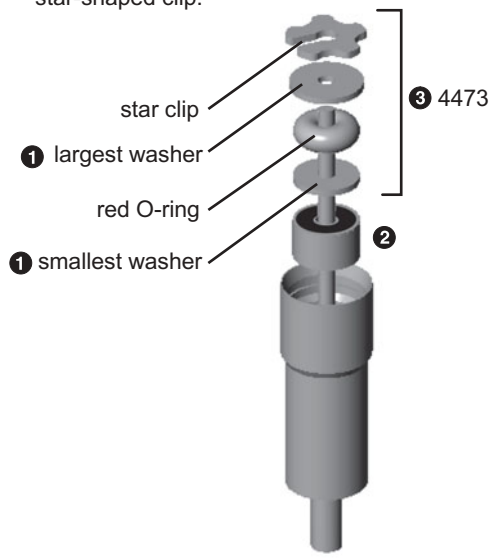

## step 10

Use the assembly tool to push all the parts down into the body until the clip snaps into the groove. When you remove the tool, the shaft will push out somewhat if everything snapped into place correctly. **Make sure the clip snaps into the groove completely.**

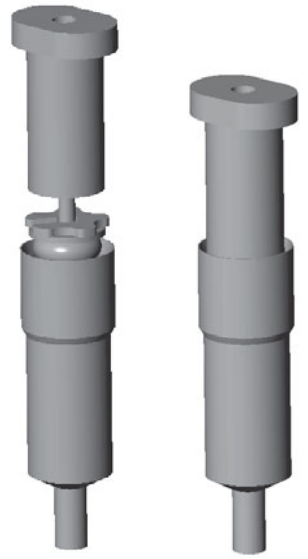

## BAG E

REMOVE THESE PARTS FOR:  
8019: steps 11-13



## TOOLS USED

.050"  
disassembly rod

## step 11

- 1 Remove the assembly tool and screw on the #6274 ball cup where shown.
- 2 Screw the #4473 spring adjusting nut onto the shock body threads, flange first, as shown.

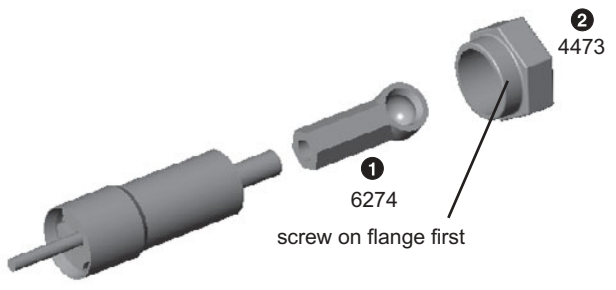

## step 12

- 1 Slide the #8451 spring over the body and up against the #4473 adjusting nut.
- 2 Screw the #6274 ball cup onto the #4471B shock shaft end.
- 3 Tighten the #4471B shock shaft end to the shaft with the #6951 set screw.

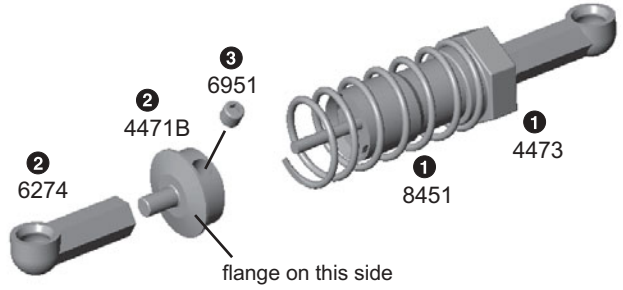

# step 13

- 1 Pop the #6274 ball cups onto the ball ends of your kit.
- 2 Turn the spring adjusting nut to adjust spring tension.

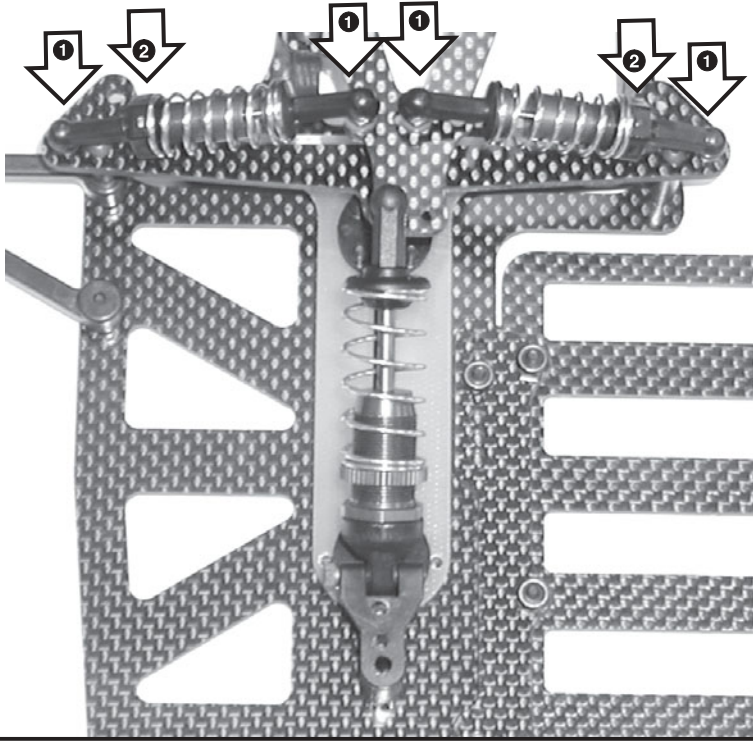

# DISASSEMBLY of side shocks

- 1 (Not shown.) To remove the parts from inside the shock, first loosen the #6951 set screw of the #4474 shock shaft end (Bag E step 12), then slide off the shaft end and spring.
- 2 Now carefully insert your disassembly rod into one of the rounded grooves of the star clip and pop it out.

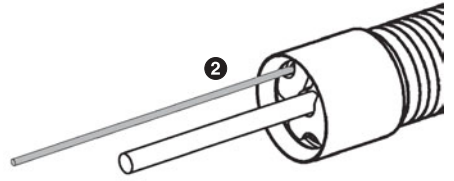

# WHEELS & TIRES

Wheels and tires are not included in this kit. To install them, use the following:

### PER FRONT WHEEL:

- Qty 2, #6902 3/16 x 5/16" flanged ball bearings
- Qty 1, #6222 4-40/5-40 nylon locknut

### PER REAR WHEEL:

- Qty 4, #6924 4-40 x 3/8" screws

Please see your local hobby shop for wheel and tire selections.

# BAG F

REMOVE THESE PARTS FOR:

8019: steps 1-2

 <b>1:1</b> 4449, qty 2 4-40 locknut	 <b>1:1</b> 4145, qty 4 4-40 x 5/16 blue aluminum	 <b>1:1</b> 7337, qty 4 #4 washer	 <b>1:1</b> 4448, qty 2 ball end blue aluminum	 <b>1:1</b> 6934, qty 2 4-40 x 3/8 blue aluminum	 8445, qty 1 servo saver	 8445, qty 1 servo saver screw
 8445, qty 1 servo saver adapter		 8435, qty 2 servo mounting block				

# TOOLS USED

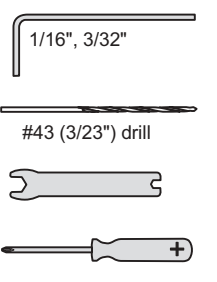

# step 1

## DRILLING STEERING SERVO BLOCKS

Drill two holes with a #43 (or 3/32") drill into the #8435 servo blocks where shown for your servo size. **DO NOT drill at an angle to the slanted face!**

for large servos,  
drill these two

for small servos

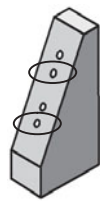
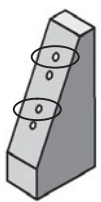

drill into block  
perpendicular to  
the slanted face

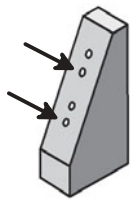

**NO!** Don't drill into the  
block at an angle to the  
slanted face

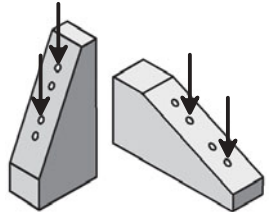

# step 2

## Installing the servo

- Secure the servo to the blocks with four #4145 blue aluminum screws and four #7337 #4 washers.

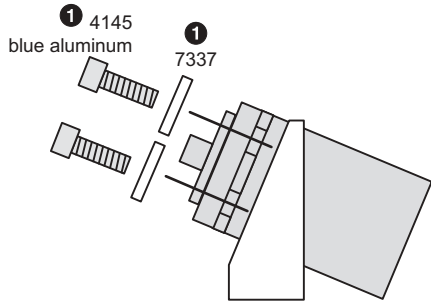

## Assembling the servo saver

- Thread two #4448 ball ends into the front side of the #8445 servo saver. Secure the ball ends with the #4449 locknuts.

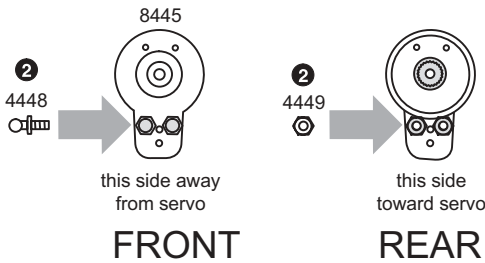

- Try the three #8445 adapters on the servo until you find one that fits. Push that adapter into the servo saver.

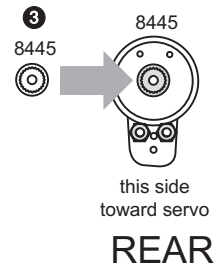

## Mounting the servo assembly

- Mount the servo saver to the servo with the #8445 screw. **Note:** If you have a metal gear servo, use the stock mounting screw.
- Mount the servo mounting blocks to the chassis with two #6934 screws. **Be sure to use the forward set of holes in the chassis.**

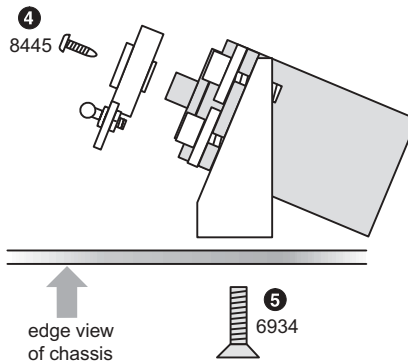

# BAG F

REMOVE THESE PARTS FOR:

8019: steps 3-4

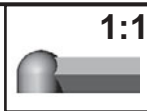

6274, qty 4  
ball cup

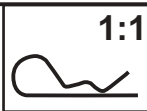

6332, qty 4  
body clip

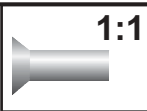

6942, qty 2  
8-32 x 1/2  
blue aluminum



6943, qty 2  
8-32 locknut  
blue



8185, qty 2  
body mount



1405, qty 2  
1.875" steering turnbuckle, blue titanium



8488, qty 1  
front bumper

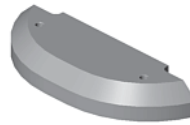

8305, qty 1  
foam bumper  
(shows edge shaved)

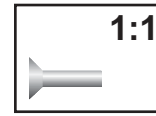

6292, qty 2  
4-40 x 3/8

## TOOLS USED

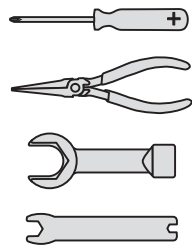

# step 3

## STEERING LINKAGE

- Install two #6274 ball cups onto the #1405 titanium steering turnbuckles. Match the length of the turnbuckles to the actual size picture below.
- Snap one turnbuckles's ball cup onto the ball end on the servo saver. Snap the opposite end on as shown. Install both turnbuckles.
- When you are adjusting your turnbuckles, always make sure that the servo saver is pointing straight down.

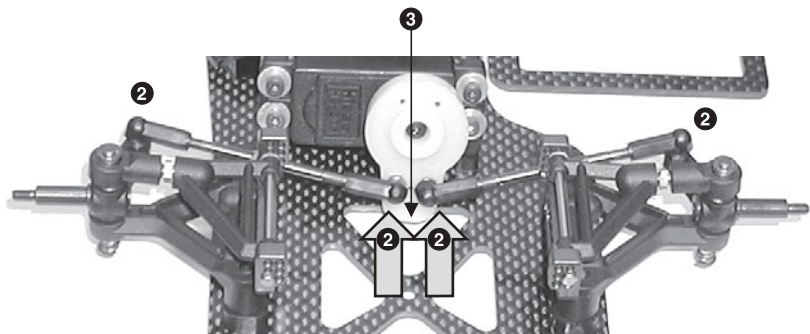
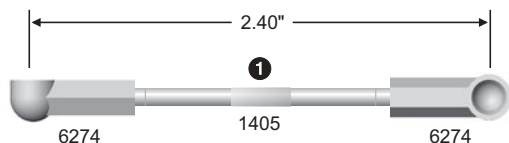

# step 4

## Front bumper

- 1 Bolt the #8488 front bumper to the front of the chassis with two #6942 blue screws from underneath and two #6943 blue locknuts on top.

## Front body mount posts

- 2 Tighten the #8185 body mounts to the bumper where indicated with two #6292 screws from underneath.
- 3 Cut and trim the #8305 foam bumper with a sanding block to fit the body of your choice and slide it over the two body mounts.
- 4 (Not shown.) Add #6332 body clips to the front posts and the rear.

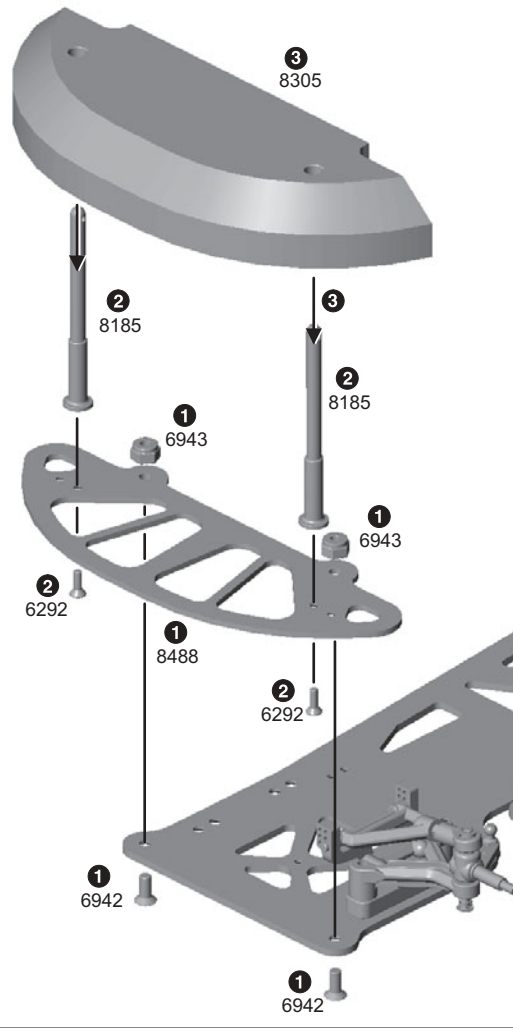

# BAG E

REMOVE THESE PARTS FOR:  
8019: steps 5-6



7337, qty 2  
washer  
gold, steel

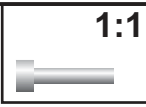

6515, qty 2  
3mm x 10mm  
gold

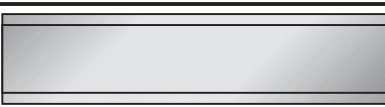

6727, qty 1  
servo tape strip



3716, qty 1  
antenna



3716, qty 1  
antenna cap

# TOOLS USED

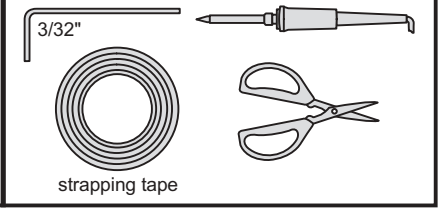

# step 5

## Motor installation

- 1 Insert the optional motor into the rear pod assembly as shown.
- 2 Begin tightening the two #6515 motor screws and #7337 gold washers till motor is against motor bulkhead.
- 3 Slide optional pinion gear onto motor shaft so that gear is 1/16" away from motor can. Teeth side should be farthest from can. Tighten set screw to hold pinion in place.
- 4 Set gear mesh so that there is very little play between #8282 spur gear and optional pinion. Then completely tighten motor screws.

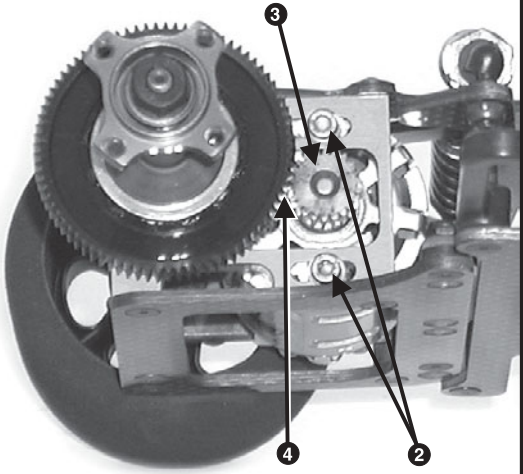
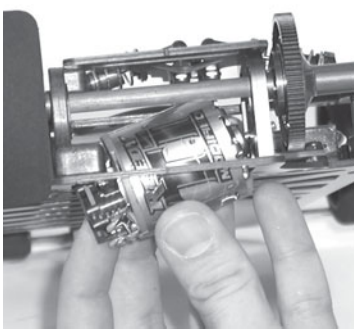

**MOTOR AND PINION GEAR ARE NOT INCLUDED IN KIT**

# step 6

## ELECTRICAL INSTALLATION

- 1 Solder your single cell batteries together with battery braid or battery bars. Solder plus (+) to minus (-).
- 2 Hold the batteries to the chassis with strapping tape. Wrap the tape over the batteries, through the chassis slot, underneath the chassis, and up again through another slot, several times.
- 3 Cut the #6727 servo tape to fit the bottom of the speed control and receiver. Peel the backing from the servo tape and place them where shown in the drawing.
- 4 Slide your receiver antenna wire through the antenna and secure the wire with the antenna cap. Insert the #3716 antenna into the antenna mount.
- 5 Now connect the electronic speed control and steering servo to your receiver according to your radio or ESC instructions, then connect the motor to the ESC and battery.

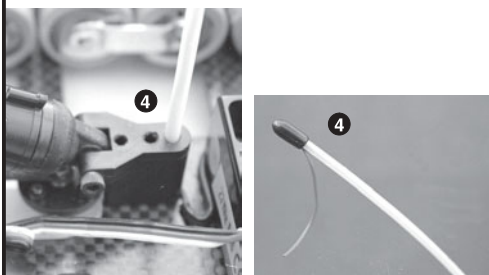
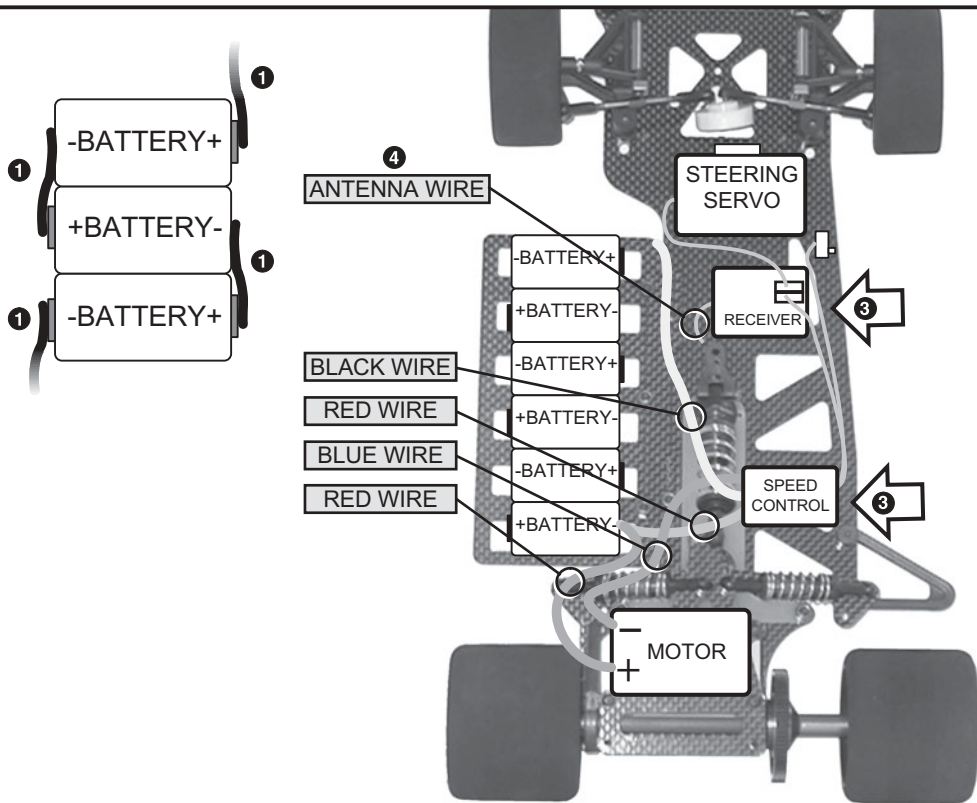

**ELECTRICAL ITEMS ARE NOT INCLUDED IN KIT**

# FINAL ADJUSTMENTS MAKE THESE ADJUSTMENTS BEFORE RACING

## CORRECTING THE TWEAK

We correct the "tweak" after everything except the body is installed on the car, including batteries, motor, speed control, and all the radio equipment.

**WHAT IS TWEAK?** Ideally, the left front wheel should be pushing down on the ground with exactly the same force as the right front wheel. If this is not happening, the car needs to have the tweak adjusted. This can cause the car to spin out easily under acceleration. It will also cause the car to oversteer in one direction and understeer in the opposite direction.

### CHECKING THE TWEAK

Start with both side shock's adjustment nuts with about one thread showing.

- 1 Measure the front chassis width. Use half of this measurement to find the centerline of the chassis.
- 2 Scribe the centerline at the front of the chassis with your hobby knife.
- 3 Place the tip of a hobby knife on the center mark as shown.

- 4 Lift the front of the car slowly. We want both front tires to leave the ground at the same time. If one tire leaves the ground before the other one, the car is tweaked.

### CORRECTING THE TWEAK

After using the method described above, tighten the side shock adjusting nut 1/2 of a turn on the tire side that left the ground first. Recheck the tweak. Continue to make these adjustments until you achieve the amount of weak desired.

*Here are some guidelines to consider when adjusting the tweak:*

Both tires leave the ground at the same time: neutral, easy-to-drive steering.

Left front tire leave the ground first: less steering (understeer).

Right front tire leave the ground first: more steering (oversteer).

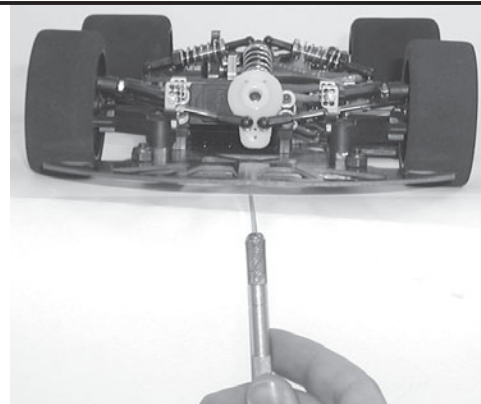

## TIRE DIAMETER ADJUSTMENT

If you change tire diameter you can affect your gearing. You can calculate any gearing adjustments by using the following formulas.

$$\frac{\text{Old Tire Dia.}}{\text{New Tire Dia.}} = \text{Factor}$$

(2.1" divided by 1.9") = 1.105

$$\text{Old Pinion Gear} \times \text{Factor} = \text{New Pinion Gear}$$

18 X 1.105 = 19.89 = 20 (round to nearest whole number)

## MOTOR GEARING

To get the most from your motor proper gearing is important. The gear ratios listed in the chart below are recommended starting gear ratios. Ratios can vary from track to track but you should not change the pinion size more than one tooth from the recommended ratio.

**CAUTION!** Increasing the pinion size by more than one tooth can damage your motor from excess heat.

MOTOR	PINION	SPUR
24° ROAR stock motor	22	81
14 turn modified motor	19	84
13 turn modified motor	18	84
12 turn modified motor	17	84

**DIFFERENTIAL MAINTENANCE**

You should rebuild the differential when the action gets somewhat "gritty" feeling. Usually cleaning the diff and applying new lube per the instructions will bring it back to new condition. Normally, as the parts seat, the diff will get smoother. If, after carefully cleaning and relubing the diff parts, the diff still feels gritty, the 1/8" balls and drive rings should be checked and possibly replaced.

**DIFFERENTIAL ADJUSTMENT**

While holding both rear wheels with your hands as shown, use your right thumb and index finger to try and rotate the spur gear. The spur gear should be very difficult to rotate. If you can rotate it easily, then tighten the #4185 11/32" nut at the end of the axle, **a little at a time**, until the spur gear is difficult to rotate.

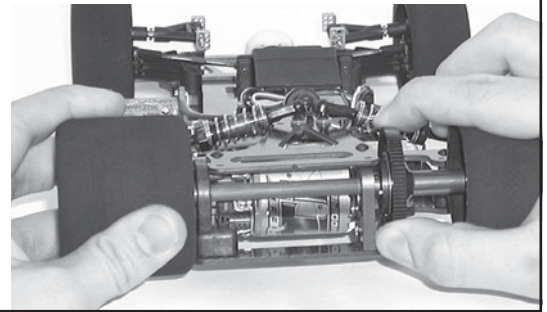
**TUNING & SETUP TIPS****THESE STEPS PREPARE YOUR CAR FOR MAXIMUM PERFORMANCE**

Your car is one of the most tunable on road cars on the market. This section will try to explain the parts and adjustments you can use to tune your car for different track conditions.

**CASTER**

Caster describes the angle of the kingpin as it leans toward the rear of the vehicle. As an example, 0° of caster puts the kingpin in a vertical line. Positive caster means the kingpin leans rearward at the top.

Increasing the positive caster on your car will slightly increase the steering into the corner but it will slightly decrease the steering exiting the corner.

Reducing the positive caster will decrease the steering into the corner but it will increase the steering middle and exiting the corner.

Your car has adjustable caster in 2° increments using the #8413 white caster shims on your front end (see page 4 for view). With the IRS caster blocks the caster can be adjusted as follows:

2 caster shims behind the upper arm = 0° of caster.

1 shim in front and 1 behind the upper arm = 2° of caster.

2 shims in front of the upper arm = 4° of caster.

**UPPER ARM PLACEMENT**

Your kit comes with the adjustable IRS front caster blocks. The caster blocks have six different mounting holes to achieve any steering feel you need for any track.

The differences between the outer and inner hole on the caster block affects how aggressive (steering reaction) the steering feels. The outer holes have the most aggressive feel as you move the arm to the inner holes the steering gets less aggressive.

Moving the upper arm up and down you will achieve how much steering your car will have. By having the arm in the lower position you will have the most steering as you move the upper arm up you will start decreasing steering. Use the diagram to help you choose the arm placement for your track conditions.

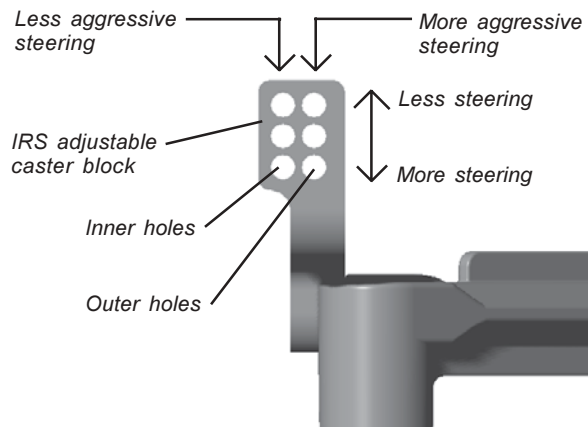
**UPPER ARM PLACEMENT, LEFT FRONT****T-BAR FLEX**

Look at the back end of the of the T-bar at the "T" shaped section. You will see there are three holes which can be used to attach the T-bar to the lower rear pod plate. You have assembled your car using only the two outermost holes. This setup will make the rear suspension very active (soft) front-to-rear. Your car will have more rear traction and will accelerate through bumps better than if you were using all three attachment holes. Try using all three attachment holes when racing on smooth, high traction conditions.

**T-BAR FLEX**

Use all three holes for smooth, high traction tracks

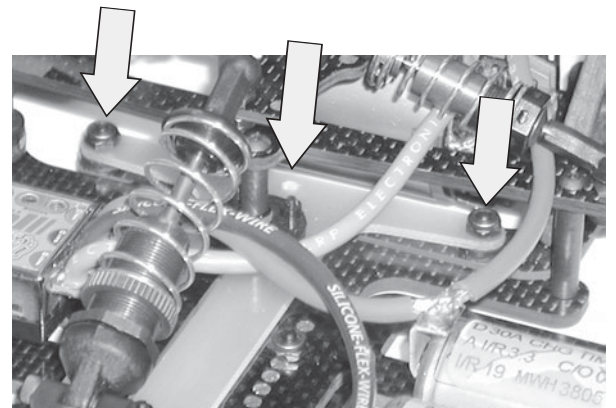

**TOE-IN AND TOE-OUT** is a beneficial adjustment and has a fairly significant effect on the car. Toe-in will help stabilize your car and it also removes a small amount of turn in steering. Toe-out will allow the car to turn in to a corner quicker but will reduce stability exiting the corner. Both toe-in and toe-out will scrub speed so try to use as little, of either, as possible. You adjust the toe-in or toe-out by adjusting the length of the steering tie-rod turnbuckles.

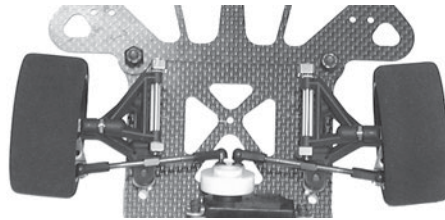

**TOE-IN**

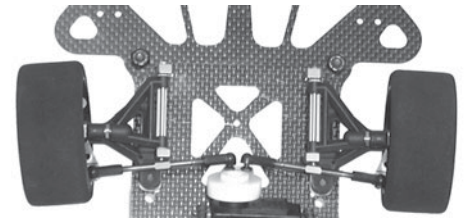

**TOE-OUT**

**FRONT SUSPENSION SPRINGS**

are available in various wire sizes as listed below. Changing springs will increase or decrease steering. In general a softer spring (smaller wire diameter) will add steering and a harder spring (larger wire diameter) will decrease steering. Oval racing will normally require a harder spring than road course racing.

Part Number	Wire Size	
#8433	(.024")	Harder (less steering)
#8431	(.022")	
#8429 (std in kit)	(.020")	
#8427	(.018")	Softer (more steering)

**REAR AXLE HEIGHT ADJUSTERS**

Your car comes with four sets of rear axle height adjuster inserts. These inserts allow you to raise or lower the height of the back of the car without changing tire diameters. Even though there are only four offsets, three can be rotated 180° for a total of seven different axle heights as shown.

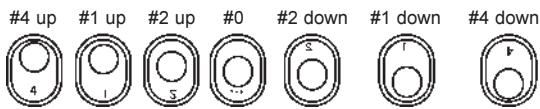

#4351	#4
#4349	#1 (std in kit)
#4350	#2
#4348	#0

The #4-up position allows you to use the maximum diameter tire and the #4-down position requires you to use the minimum tire diameter. This adjustment allows you to get more useful life from

a set of tires by adjusting axle height as tire diameter decreases. You can also adjust the overall height of your car for high or low traction conditions.

**BATTERY PLACEMENT**

By moving your batteries farther to the left in the chassis battery slots, you can improve cornering performance on tight, low bank (or flat), oval tracks. If the track you drive on has substantial banking, or is very large, try moving your battery closer to the middle of the chassis. This will make your car less aggressive in the corners and be easier to drive. Moving the cells to the outside will give you more steering.

The battery mounting tray allows you to slide the batteries forward or back using the preset holes. Generally, by sliding the batteries forward, you'll achieve more steering. Sliding the tray back can give more rear traction.

Use the optional #8491 tray for 4 cell racing.

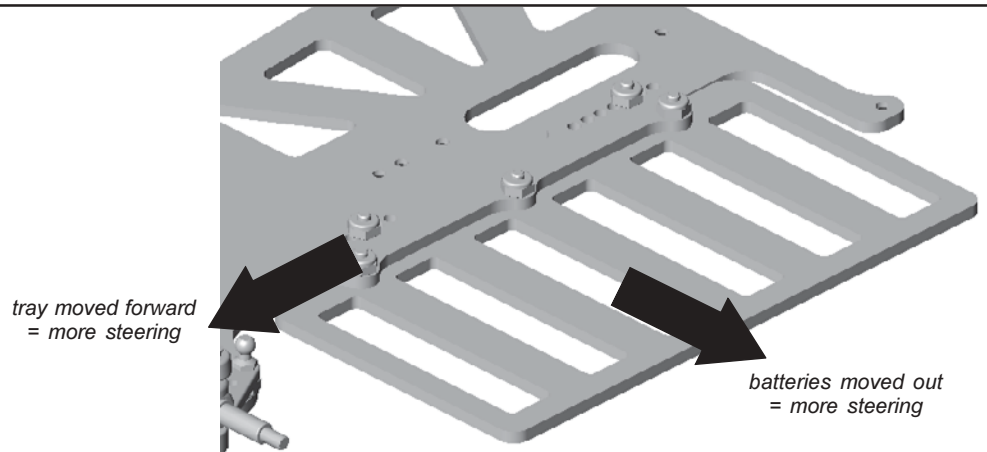

**BATTERY PLACEMENT**

**LESS AGGRESSIVE STEERING**

If the steering of your car is too aggressive, replace the standard steering block and axle with the optional #8421 steering block and #3213 axle. This also requires the #3655 ball bearings.

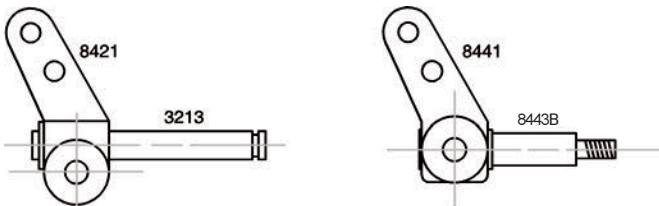

**OPTIONAL, OFFSET      STANDARD, IN-LINE**

**SAVE THIS BOOKLET!**

More than an instruction manual, it's also a handy pictorial supplement to Team Associated's catalog.

Refer to this manual for part numbers and description when ordering parts or explaining problems for customer service calls.

For the most up-to-date parts and catalog information, please use the online products catalog at <http://www.TeamAssociated.com/>

The web site also includes setup sheets, new product information, tuning tips, customer support help, computer wallpaper, catalogs and manuals, a directory of hobby shops and tracks worldwide, fun videos, and a form to subscribe to the FREE *Team Associated Insider's Newsletter*.

**CAMBER** describes the angle of the tire and wheel relative to the ground when looked at from the front or back. This is one of the most important adjustments on the car. Negative camber means that the tire leans inward at the top. Positive camber means that the top of the tire is further away from the centerline of the car than the bottom of the tire.

Excessive negative camber will decrease traction but increase stability. Positive camber will do the same. We suggest a starting with 2° of

negative camber on the right front and 0° camber on the left front. Try to use at least 1 to 2° negative camber at all times and make adjustments to keep your tires wearing flat.

Camber is adjusted by turning the upper arm turnbuckles in the appropriate direction.

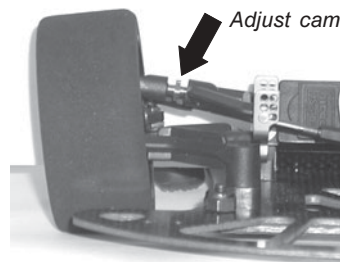

**POSITIVE CAMBER**

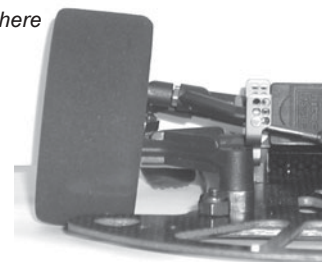

**NEGATIVE CAMBER**

## OPTIONAL OFFSET REAR POD

By changing the mounting offset of the rear pod, you can improve cornering performance on tight, low banked (or flat) oval tracks. If the track has substantial banking or is very large, try using the standard mounting position. Refer to the drawings for correct mounting positions.

### CENTERED POD, OPTIONAL

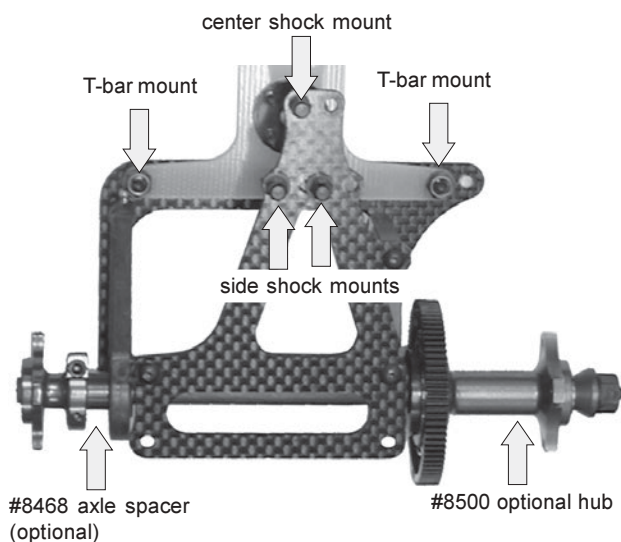

### OFFSET POD, STANDARD

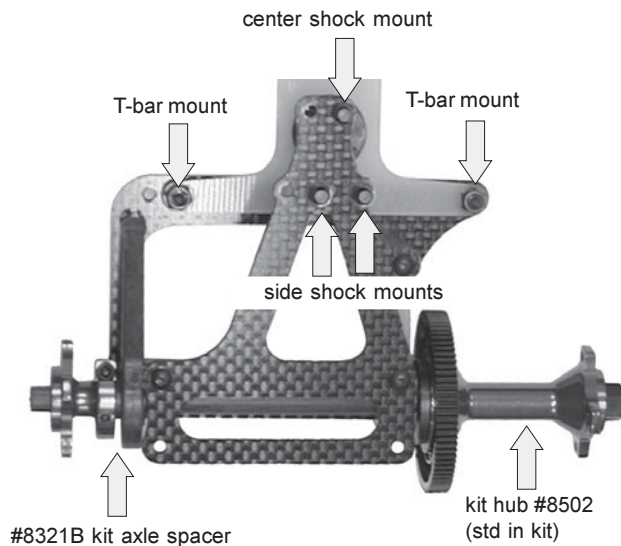

## STANDARD SETTINGS FOR THE 10L4 OVAL

### FRONT SUSPENSION

Caster shim position  
 RF: 1 each side (arm centered)  
 LF: 1 each side (arm centered)  
 Camber, RF: 2 deg., LF: 0 deg.  
 Toe: 1/16" total toe-out  
 Steering block: inline  
 Front upper arm placement:  
 RF: lower outside  
 LF: lower outside

### REAR SUSPENSION

Axle height adjuster: #1-up  
 Pod: offset  
 T-Bar thickness: .075"  
 Rear axle spacing, RR: , LR:  
 Right rear hub: long?  
 T-Bar flex: 2 holes

### SHOCKS:

**Center shock**  
 Body: threaded  
 Oil weight: 30  
 Spring: silver  
 Shaft: Unobtainium  
 Piston: #1

### Side shocks

Body: STD VCS  
 Oil weight: 30  
 Spring, RR: silver, LR: silver

### TIRES

Tire compound: varies  
 Tire diameter: varies  
 Tire width: varies  
 Tire treatment type: none  
 Tweak:  
 RF: oz. varies  
 LF: oz. varies  
 RR: oz. varies  
 LR: oz. varies

### FRONT SPRINGS

Springs: RF: .020, LF: .020  
 Kingpin: STD.  
 Top shim qty, RF: 4-#8425, LF: 4-#8425  
 Bottom shim qty, RF: 1-#8425, LF: 1-#8425  
 Front ride height spacers: 1-#8179

### OTHER

Car body: varies  
 Wing type: varies  
 Motor: varies  
 Turns/Winds: varies  
 Pinion/Spur: varies/81T, 48P  
 Batteries: varies  
 Battery tray type: 6 cell  
 Battery pack placement: all the way to the left  
 Battery tray mounting: 3rd hole from rear  
 Wheelbase: std  
 Overall weight: varies

# SETUP SHEET

## FOR THE RC10L4 OVAL KIT



http://www.TeamAssociated.com/

DATE: \_\_\_\_\_  
 DRIVER: \_\_\_\_\_  
 TRACK LOCATION: \_\_\_\_\_  
 EVENT: \_\_\_\_\_

### FRONT SUSPENSION

CASTER SHIM POSITION:

RF:  Rear 0°  Split 2°  Front 4°

LF:  Rear 0°  Split 2°  Front 4°

CAMBER, RF: \_\_\_\_\_ LF: \_\_\_\_\_

TOE-IN: \_\_\_\_\_° TOE-OUT: \_\_\_\_\_°

STEERING BLOCK:

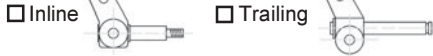

FRONT UPPERARM  
PLACEMENT

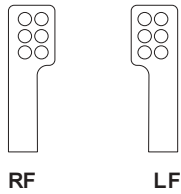

### FRONT SPRINGS

SPRINGS RF:  .018  .020  .022  .024 other \_\_\_\_\_

LF:  .018  .020  .022  .024 other \_\_\_\_\_

KINGPIN:  STD other \_\_\_\_\_

shim qty/thickness, RF: \_\_\_\_\_ LF: \_\_\_\_\_  
 shim qty/thickness, RF: \_\_\_\_\_ LF: \_\_\_\_\_

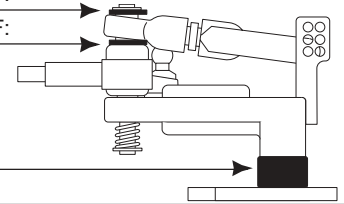

front ride height spacers: \_\_\_\_\_

### REAR SUSPENSION

AXLE HEIGHT ADJUSTER:

4-up  1-up  2-up  #3  2-down  1-down  4-down



POD:  INLINE  OFFSET

T-BAR THICKNESS:  .075  .063 other \_\_\_\_\_

REAR AXLE SPACING, RR: \_\_\_\_\_ shims

LR: \_\_\_\_\_ shims

RIGHT REAR HUB,  STD (short)  offset (long)

T-BAR FLEX:  2 holes  3 holes

### SHOCKS

CENTER SHOCK:  threaded other \_\_\_\_\_

OIL: \_\_\_\_\_ WT SHAFT:  Unobtainium other \_\_\_\_\_

SPRING: \_\_\_\_\_ PISTON:  #1  #2  #3 other \_\_\_\_\_

SIDE SHOCKS:  STD VCS other \_\_\_\_\_

OIL: \_\_\_\_\_ WT

SPRING, RR: \_\_\_\_\_ LR: \_\_\_\_\_

### TIRES

TIRES	LEFT	RIGHT
Tire Compounds F		
R		
Tire Diameter F		
R		
Tire Width F		
R		

TWEAK SETTINGS:

oz.  \_\_\_\_\_ oz. \_\_\_\_\_ oz.  
(front)

oz.  \_\_\_\_\_ oz. \_\_\_\_\_ oz.  
(rear)

TIRE TREATMENT TYPE: \_\_\_\_\_

SHADE IN AMOUNT  
OF TIRE TREATMENT

### OTHER

CAR BODY: \_\_\_\_\_ WING MOUNT:  pod  body

MOTOR: \_\_\_\_\_ WING TYPE: \_\_\_\_\_

SPORLER HEIGHT: \_\_\_\_\_

TURN/WINDS: \_\_\_\_\_ X \_\_\_\_\_ PINION/SPUR: \_\_\_\_\_ / \_\_\_\_\_

BATTERIES: \_\_\_\_\_

TRAY:  4 Cell  6 Cell BATTERY PACK PLACEMENT:

Indicate front/back placement

Shade in battery placement

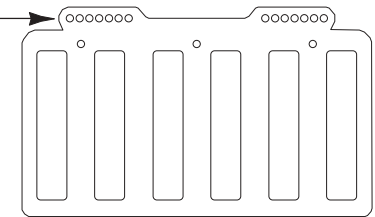

("XXX"-out unused portion of 4 cell tray)

WHEELBASE:  STD  OPT short

OVERALL WEIGHT: \_\_\_\_\_

### GENERAL

TRACK CONDITIONS:

carpet  asphalt  concrete

flat  banked, amount of banking: \_\_\_\_\_ deg.

track length: \_\_\_\_\_

high traction  med. traction  low traction

track prep (describe): \_\_\_\_\_

other: \_\_\_\_\_

RACE COMMENTS/FINISH:  TQ Main: \_\_\_\_\_ Place: \_\_\_\_\_

CAR COMMENTS/HANDLING:

# SETUP SHEET

## FOR THE RC10L4 OVAL KIT

http://www.TeamAssociated.com/



DATE: September 2002

DRIVER: Daryl, Sean

TRACK LOCATION: Hot Rod Hobbies

EVENT: Southwest Tour

### FRONT SUSPENSION

CASTER SHIM POSITION:

RF:  Rear 0°  Split 2°  Front 4°

LF:  Rear 0°  Split 2°  Front 4°

CAMBER, RF: -2° LF: +1°

TOE-IN: 0° TOE-OUT: 0°

STEERING BLOCK:

Inline  Trailing

FRONT UPPERARM  
PLACEMENT

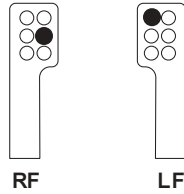

### FRONT SPRINGS

SPRINGS RF:  .018  .020  .022  .024 other \_\_\_\_\_

LF:  .018  .020  .022  .024 other \_\_\_\_\_

KINGPIN:  STD other \_\_\_\_\_

shim qty/thickness, RF: 4-.015 LF: 4-.015

shim qty/thickness, RF: 0 LF: 0

front ride height spacers: 2-0° shims

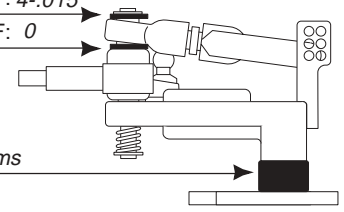

### REAR SUSPENSION

AXLE HEIGHT ADJUSTER:

4-up  1-up  2-up  #3  2-down  1-down  4-down



POD:  INLINE  OFFSET

T-BAR THICKNESS:  .075  .063 other \_\_\_\_\_

REAR AXLE SPACING, RR: 2 shims

LR: 0 shims

RIGHT REAR HUB,  STD (short)  offset (long)

T-BAR FLEX:  2 holes  3 holes

### SHOCKS

CENTER SHOCK:  threaded other \_\_\_\_\_

OIL: 40 WT SHAFT:  Unobtainium other \_\_\_\_\_

SPRING: blue buggy PISTON:  #1  #2  #3 other \_\_\_\_\_

SIDE SHOCKS:  STD VCS other \_\_\_\_\_

OIL: 30 WT

SPRING, RR: gold LR: blue

### OTHER

Protoform  
CAR BODY: 02 Monte Carlo HD

MOTOR: Reedy

TURNS/WINDS: 8 x 1

BATTERIES: Reedy X-Cell 3300

WING MOUNT:  pod  body

WING TYPE: Lg Thunder Wing

SPOILER HEIGHT: .50"

PINION/SPUR: 120 / 27

TRAY:  4 Cell  6 Cell

BATTERY PACK PLACEMENT:

Indicate front/back placement

Shade in battery placement

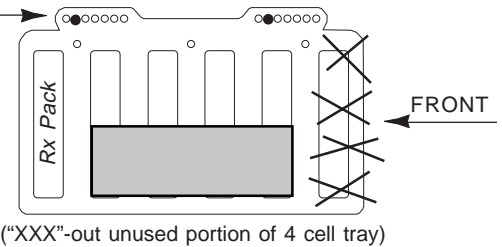

("XXX"-out unused portion of 4 cell tray)

WHEELBASE:  STD  OPT short

OVERALL WEIGHT: 38.3 oz.

### TIRES

TIRES	LEFT	RIGHT
Tire Compounds F	<u>Pink</u>	<u>Purple</u>
R	<u>Pink</u>	<u>Purple</u>
Tire Diameter F	<u>2.28</u>	<u>2.28</u>
R	<u>2.28</u>	<u>2.28</u>
Tire Width F	<u>std</u>	<u>std</u>
R	<u>std</u>	<u>std</u>

TWEAK SETTINGS:

oz. oz. (front)

+2.0 oz. oz. (rear)

TIRE TREATMENT TYPE:

Paragon Ground Effects

SHADE IN AMOUNT OF TIRE TREATMENT

### GENERAL

TRACK CONDITIONS:

carpet  asphalt  concrete

flat  banked, amount of banking: \_\_\_\_\_ deg.

track length: 220'

high traction  med. traction  low traction

track prep (describe): none

other: \_\_\_\_\_

RACE COMMENTS/FINISH:  TQ Main: A Place: 1st

CAR COMMENTS/HANDLING: