

# TEAM LOSI MINI-T

**1/18TH SCALE RTR VERSION OF THE CHAMPIONSHIP WINNING XXX-T**



Visit [www.modelflight.com.au](http://www.modelflight.com.au) for more information and spare parts online.



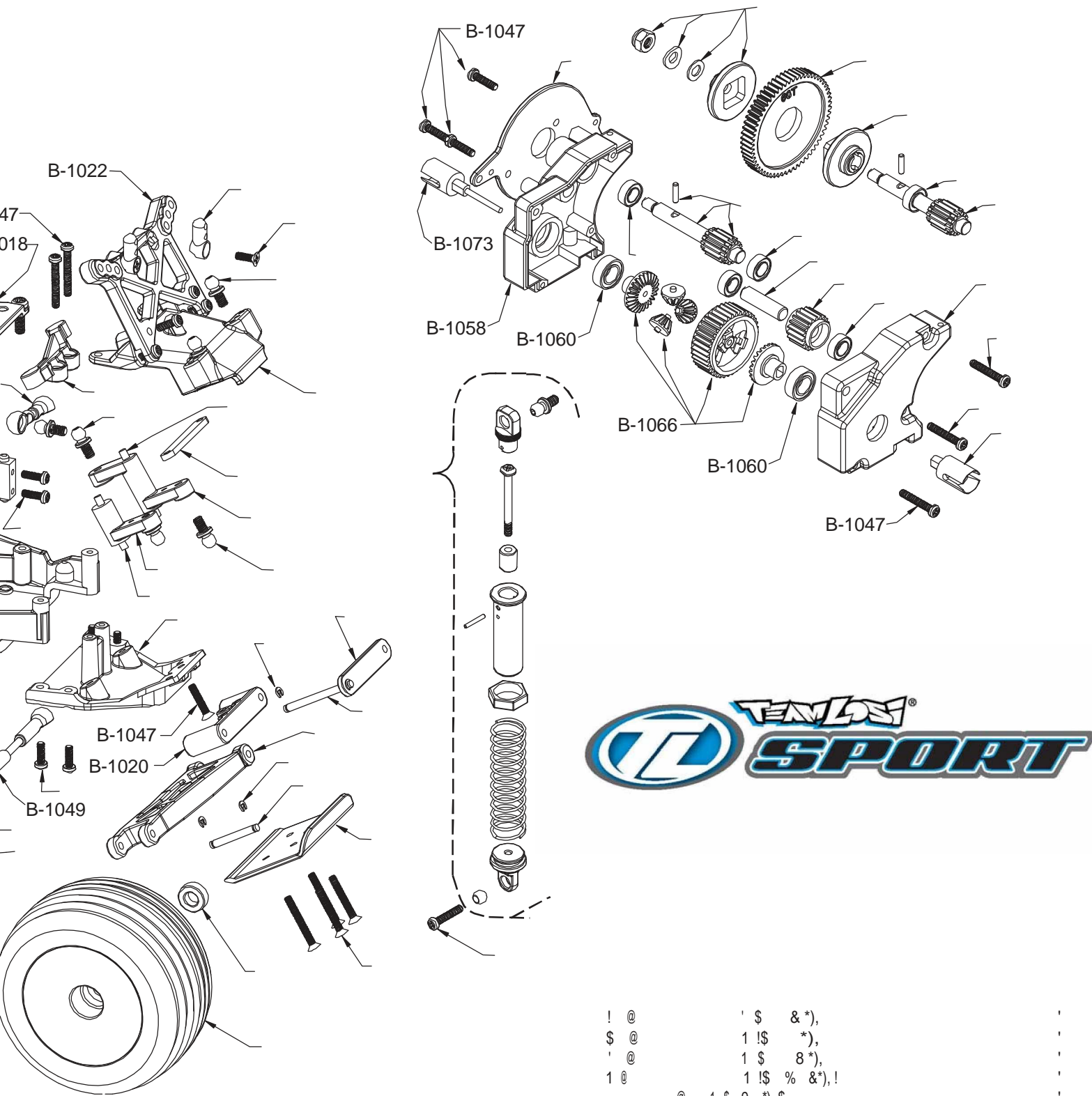

! @ ' \$ & \*), ' :  
 \$ @ 1 \$ \*), :  
 ' @ 1 \$ 8 \*), :  
 1 @ 1 \$ % & \*), ! :  
 @ 1 \$ 9 \*), \$ :  
 @ 1 \$ \$ \*), ' :  
 " 9 ( 8 8 \$  
 ' 9 8 \$  
 1 9 ) + 4:8- 62 \$  
 1' 3 <, + + / 8 0 \$  
 1 <, + + / 8 0 \$  
 ! + ! ,  
 \$ + " 6 ! ,  
 1 " + " ? !  
 & \* & + ( 8+ !  
 /" ( 0 !  
 9 !

! @ ' \$ & \*), ' :  
 \$ @ 1 \$ \*), :  
 ' @ 1 \$ 8 \*), :  
 1 @ 1 \$ % & \*), ! :  
 @ 1 \$ 9 \*), \$ :  
 @ 1 \$ \$ \*), ' :  
 8 ? (8 /<, + 7 -+0 !  
 \$ 3 <, + / (OA & !  
 \$ 3 <, + / (OA ), !  
 \$ 3 + & \* > / (OA : " - !  
 ' <, + / (OA & !  
 ' <, + / (OA ), !  
 ' + & \* > / (OA ( !  
 1 \$ 3 : " + ), <, + 4 8 !  
 1 ( + ), <, + 4 8 !

# GETTING STARTED

**NOTE:** Before you start running your new Mini-T, it is absolutely necessary that you read through all of the operating instructions to get the maximum enjoyment and prevent unnecessary damage.

## Step 1

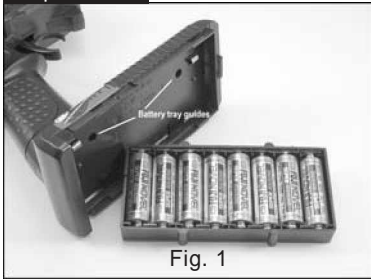

Remove the transmitter battery tray by sliding the bottom cover. Install eight (8) AA alkaline batteries into the battery holder. Pay close attention to the correct direction of the positive (+) and negative (-) ends as marked in the tray. Reinstall the battery tray using the molded pegs in the bottom as a guide for the correct location and replace the bottom cover.

## Step 4



Remove the battery box top by lightly prying the bottom rail of either end of the retaining clip. Install four (4) AA alkaline batteries into the battery box, again paying close attention to the correct direction of the cells. Replace the cover and make sure the retaining clips snap over the rails at either end.

## Step 2

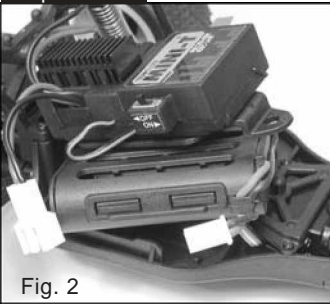

After removing the body, remove the small hatch pin just in front of the receiver above the steering servo. Carefully swing the plate with the receiver/speed control upward and remove the battery box.

## Step 5



Install the battery box with the plug at the right front corner. Let the receiver/speed control plate drop over the batteries onto the mounting post and replace the hatch pin that secures it in place. Plug in the battery using the slots and bars molded into the plugs as a guide and you are ready to go!

## Step 3

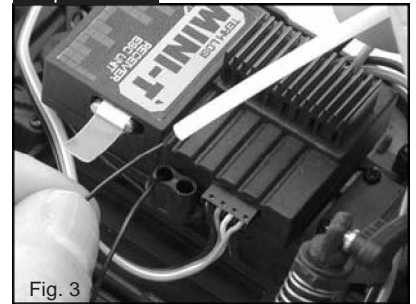

Insert the antenna wire through the antenna mount and into the antenna tube pushing it through until it comes out the other end. Push the antenna tube into the antenna mount.

## Step 6

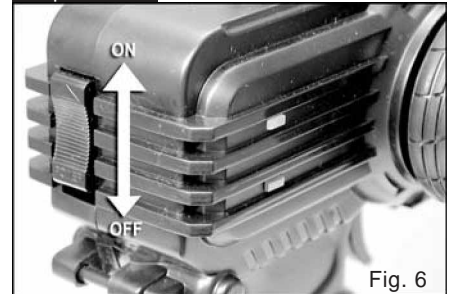

**Always** turn on the transmitter first by sliding the switch on the left side upward. The small red and green lights to the left of the steering wheel should both light up. If not you need to check for low or incorrectly installed batteries.



## Step 7

Turn on the Mini-T by sliding the switch on the right side of the receiver forward (Fig. 5.) as noted on the side of the switch. If the rear wheels turn, adjust the "TH. TRIM" knob (Fig. 8) located to the lower right of the steering wheel until they stop. To go forward pull the trigger back. If you should need reverse, wait for the model to stop then push the trigger forward. When going forward the model should move in a straight line. If not, adjust the "ST. TRIM" (Fig. 8) so that it tracks in a straight line without having to turn the steering wheel.

After you are done running, turn the Mini-T off **FIRST** by sliding the switch toward the back of the truck (Fig. 5). After the model has been turned off, turn off the transmitter (Fig. 6). If you wish to clean your Mini-T, use compressed air and / or a soft paintbrush to remove dust and dirt. **NEVER** use chemicals or anything wet as it can cause damage to both the electronics and plastic parts.

## ALWAYS

- ◆ Turn on the transmitter before the truck
- ◆ Use caution when running around people
- ◆ Turn both the Mini-T and transmitter "off" when done
- ◆ Check the battery condition of the transmitter before running.

## NEVER

- ◆ Operate the Mini-T with low battery power.
- ◆ Run the Mini-T through water or wet grass
- ◆ Use chemicals to clean the chassis
- ◆ Run the Mini-T without a gear cover