

Sportwerks® Raven™ BX RTR Assembly and Operation Manual



Specifications:

Scale	1/10
Length	15 in (381mm)
Front Track	9.75 in (248mm)
Rear Track	10 in (254mm)
Weight	Varies with battery used
Wheel Size	2.2 in

Table of Contents

Introduction	2
Warranty	3
Safety Precautions	3
Required Equipment	4
Tools You Will Find Handy	4
About the Radio System	5
The Receiver and Servo	6
Tazer 15T Electronic Speed Control (ESC)	6
Service and Maintenance	7
Shocks	7
Cleaning Tip	7
Motor Maintenance	8
Setting the Gear Mesh	8
Tuning Tips	9
Camber	9
Toe-In/Out	9
Ride Height	10
Battery Placement	10
Slipper Adjustment	10
Troubleshooting Guide	11
Parts Listing	12
Parts Breakdown	13-15

Introduction

Thank you for choosing the Sportwerks® Raven™ BX. Your Raven comes complete with a Sportwerks 2-channel AM radio system, Dynamite® Tazer™ 15T Electronic Speed Control and a high performance 19T motor. Although this is an entry-level radio control product, it is not a toy and requires some basic mechanical ability and adult supervision. This manual contains basic instructions for safety, operation and maintenance. It's essential to read and follow all the instructions and warnings in this manual, prior to assembly, setup or use, in order to operate correctly and avoid damage or injury.



Warranty

Horizon Hobby, Inc. guarantees this product to be free from defects in both material and workmanship at the date of purchase. This warranty does not cover any component parts damaged by use or modification. In no case shall Horizon Hobby's liability exceed the original cost of the purchased kit. Further, Horizon Hobby reserves the right to change or modify this warranty without notice.

As Horizon Hobby has no control over use, setup, final assembly, modification or misuse, no liability shall be assumed nor accepted for any resulting damage or injury. By the act of assembly, setup or use, the user accepts all resulting liability.

Your local hobby store and/or place of purchase cannot provide warranty support or repair. Once assembly, setup or use of the model has been started, you must contact Horizon Hobby, Inc. directly. This will enable Horizon to better answer your questions and service you in the event that you may need any assistance.

If you as the purchaser or user are not prepared to accept the liability associated with the use of this product, you are advised to return this kit immediately in new and unused condition to the place of purchase. For warranty issues, questions or concerns, please contact.

Horizon Product Support.
4105 Fieldstone Road
Champaign, Illinois 61822
(toll free) 877- 504-0233
productsupport@horizonhobby.com



A Division of Horizon Hobby, Inc.
www.SportwerksRC.com

Safety Precautions

The Sportwerks® Raven™ is a sophisticated radio controlled product that must be operated with caution and common sense. Failure to operate your model in a safe and responsible manner could result in injury or damage to the model or other property. This product is not intended for use by children without direct adult supervision.

Horizon Hobby shall not be liable for any loss or damages, whether direct, indirect, special, incidental, or consequential, arising from the use or misuse of this product or any product required for operating it.

- This model is controlled by a radio signal that is subject to interference from many sources outside your control. This interference can cause momentary loss of control, so it is advisable to always keep a safe distance in all directions around your model as this margin will help to avoid collisions or injury.
- Always operate your model in an open area away from cars, traffic, or people.
- Avoid running your model in the street where injury or damage can occur.
- Never run the model out into the street or populated areas for any reason.
- Never run your model with low transmitter batteries.
- Carefully follow the directions and warnings for this and any optional support equipment (chargers, rechargeable battery packs, etc.) that you use.
- Keep all chemicals, small parts and anything electrical out of the reach of children.

Moisture causes damage to electronics. Avoid water exposure to all equipment not specifically designed and protected for this purpose.



Required Equipment

You will need the following items to operate your Raven™ BX buggy.

- 8 “AA” batteries for the transmitter.
- Charger capable of charging 7.2-volt Ni-MH batteries. (We recommend the DYN4049 Prophet Plus™ LCD AC/DC Peak Charger.



Tools You Will Find Handy

In addition to the tools included in this kit, you will find the following items useful when performing maintenance or repair to your Raven BX.

- Quality tip 2.5 Allen driver
- 6.5 and 7mm nut drivers
- #2 Phillips head screwdriver
- Needle-nose pliers
- Hobby knife
- Lexan scissors



About the Radio System

The following is an overview of the operation of the Sportwerks® radio system and its various functions and adjustments. Since your Raven™ BX operates using a radio you control, it's important for you to read and understand about all of these functions and adjustments before driving.

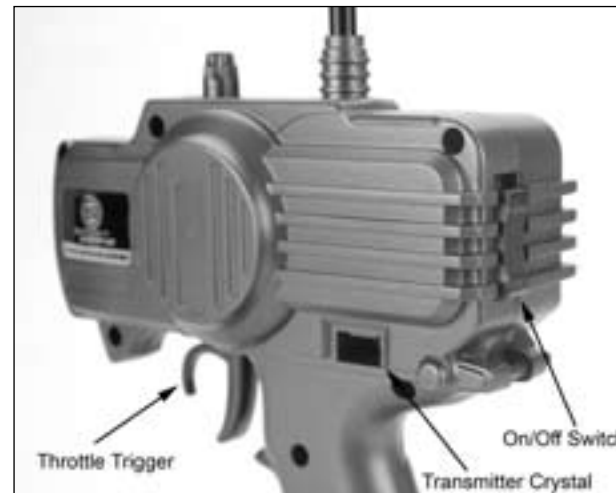
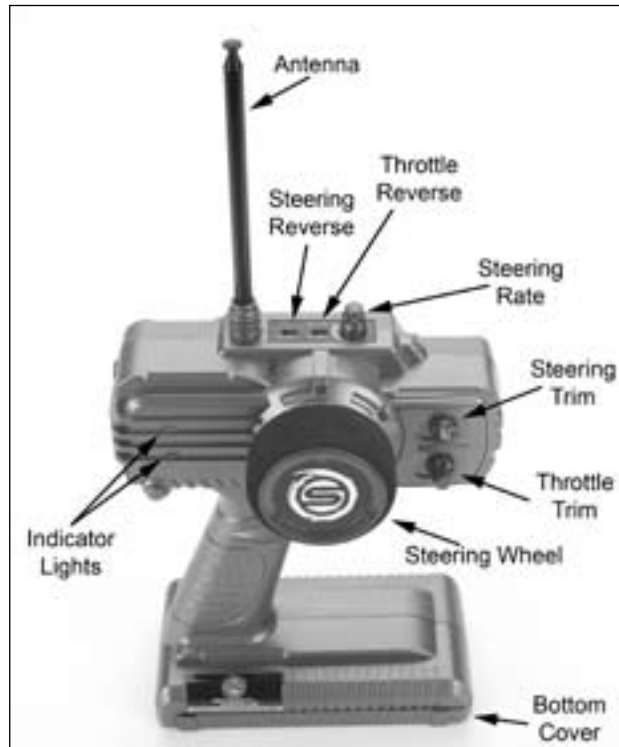

Steering Wheel: Controls direction (left/right) of the model.

Throttle Trigger: Controls speed and direction (forward/reverse) of the model.

Antenna: Transmits signal to the model.

On/Off Switch: Turns the power on for transmitter operation.

Indicator Lights: Green (top) light indicates adequate battery power. Red light (bottom) indicates signal strength.

ST. Trim: Adjusts the "hand off" direction of the model.

TH. Trim: Adjusts the motor speed to stop at neutral.

Steering Rate: Adjusts the amount the front wheel moves when turned left or right.

ST. REV: Reverses the function of the steering when the wheel is turned left or right.

TH. REV: Reverses the function of the Speed Control when pulled back or pushed forward.

Bottom Cover & Battery Tray: Covers and holds the batteries that power the transmitter.

Transmitter Crystal: Determines frequency/channel you transmit on. The receiver must have a matching frequency/channel to operate.



The Receiver and Servo

1. Receiver: Receives the signal from the transmitter to control the model.
2. Receiver Crystal: Determines which channel it will receive.
3. Antenna Wire: Receives the signal from the transmitter.
4. Steering Servo: Controls steering movement.
5. Steering Servo Plug: Connects to the receiver in position 1.



Tazer 15T Electronic Speed Control (ESC)

1. Electronic Speed Control: Controls forward, reverse, and braking functions.
2. ESC Plug: Connects to the receiver in position 2.
3. Battery Plug: Connects to the 7.2-volt battery.
4. Motor Connectors: Orange (positive) and Black (negative) will connect to the motor leads.
5. On/Off Switch: Used to turn the vehicle on.
6. Set Up Button: Used for programming the ESC.
7. Indicator Lights: Green indicates throttle at neutral position. Red indicates full forward or full reverse.

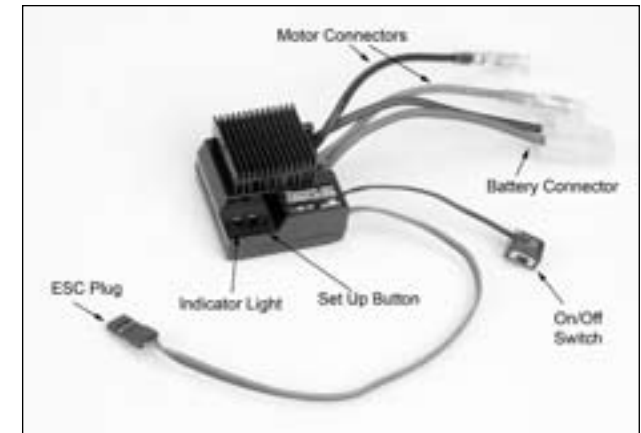

Service and Maintenance

Shocks

The shocks will need to be rebuilt periodically when the fluid gets low or dirty.

1. Remove the shocks from the vehicle, unscrew the aluminum cap, dump the fluid and clean thoroughly.
2. Refill with silicone shock fluid to the top of the body (the factory setup is 30 weight oil in the front and 20 weight oil in the rear).



3. Slowly move the piston up and down to remove air bubbles.



4. Move the piston to the midway point of the body and install the cap.



5. Tighten the cap slowly letting excess oil bleed off.



When properly filled the piston can be pushed and should rebound about 3/8".

Cleaning Tip

Performance can be hindered if dirt gets in any of the moving suspension parts. Use compressed air or a soft paintbrush or toothbrush to remove dust and dirt. Avoid using solvents or chemicals, as they can actually wash dirt into the bearings or moving parts as well as cause damage to the electronics.



Motor Maintenance

After about 10 runs, the motor should be cleaned and the brushes inspected for wear. Proper maintenance will not only increase motor life, it will improve performance.

1. You will first need to remove the gear cover and pinion gear. Then remove the 2 motor retaining screws.
2. Disconnect the bullet connectors from the ESC.
3. Remove the brush springs and brushes. Inspect the brushes (if severely worn or discolored they should be replaced).
4. Spray the motor thoroughly with a high quality cleaner like DYN5500 Magnum Force Cleaner.
5. Before re-installing, oil each motor bushing with a drop of quality bushing lubricant.

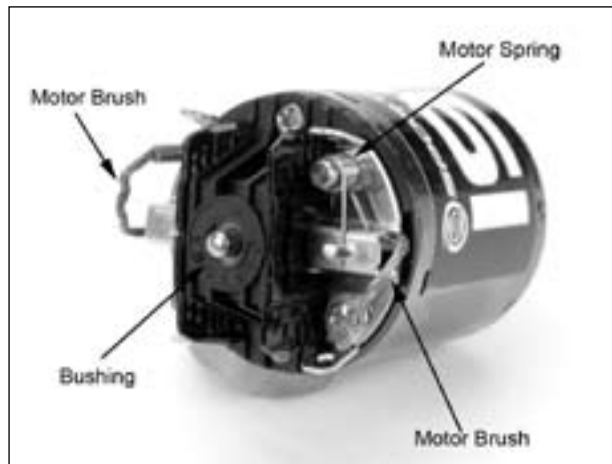

Setting the Gear Mesh

Proper gear mesh is important to the performance of your vehicle. If the mesh is too loose, it will cause the spur gear to fail (strip); if set too tight, it will decrease speed and cause the motor to overheat.

To set the gear mesh, loosen the motor screws and insert a small piece of paper between the two gears.



Push the gears together and re-tighten the screws. Finally remove the paper, the gear should be able to rock back and forth slightly.



Tuning Tips

Camber

Camber is the angle of the tires to the racing surface when viewed from the front or rear of the vehicle. With negative camber, the wheel leans inward and with positive camber, the wheel leans outward.

The best setting range is between 0 and 1 degrees negative camber. More negative camber in the front will result in a more aggressive feel, increases steering and improves handling through bumpy sections. More negative camber in the rear will decrease side bite and increase steering. Camber can be adjusted by lengthening or shortening the threaded turnbuckles. Many dealers sell inexpensive adjustment tools for measuring camber.

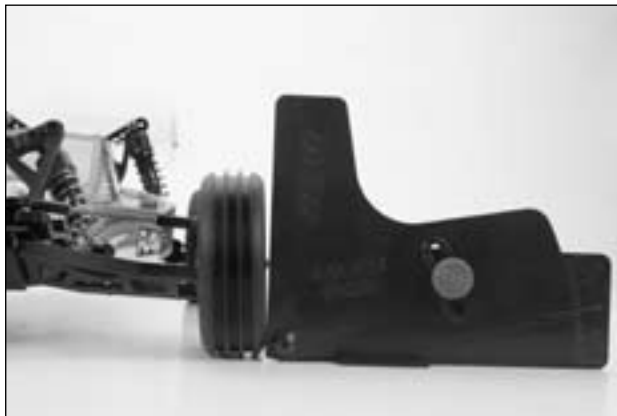

Toe-In/Toe-Out

Toe-in (negative toe) and toe-out (positive toe) refers to the angle of the tires as viewed from the top of the vehicle. Toe-in will provide more stability under acceleration but decreases steering on corner entry. Toe-out will improve steering into corners but not be as stable at full speed. The factory setting is 0 degrees. Toe can be adjusted by lengthening or shortening the threaded steering links.

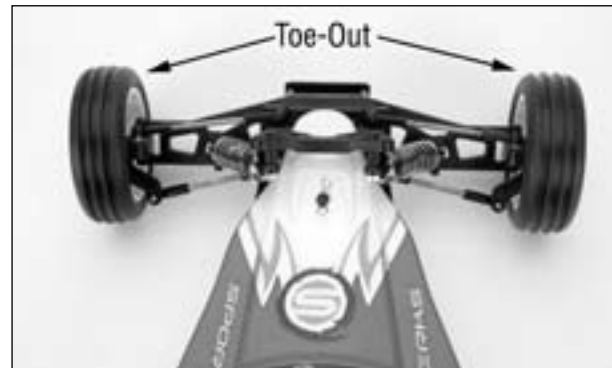

Ride Height

Ride height is an adjustment that affects the way your car jumps, turns, and goes through bumps. To check the ride height, drop one end of the buggy from about 6 inches onto a flat surface. Once the buggy settles into position check to see that the front arms are equal and level to the ground. When looking at the rear, it should be set so that both dogbones are level to the ground. Lowering the front ride height will increase the amount of steering; lowering the rear will increase traction but decrease steering.

Battery Placement

The battery position in your Raven™ BX can be adjusted by moving the foam block provided with your kit. Moving the battery forward will increase steering. Moving the battery to the rear will increase traction.

Slipper Adjustment

The slipper clutch helps eliminate parts breakage in the transmission and also aids drivers in low traction conditions coming off corners and landing jumps. To adjust the slipper tension, simply loosen or tighten the nut on the outside of the spur gear. Set your vehicle on the ground and punch the throttle. The slipper should slip for one to two feet at most. If it doesn't slip for at least one foot, back the nut off 1/8 of a turn and retry.



Troubleshooting Guide

Problem	Things to Check	Remedy
Short Runtime	Battery not charged/bad	Check/charge battery pack
	Motor dirty or brushes worn	Clean/replace
Sluggish Action	Motor dirty/brushes worn	Clean/replace
	Bind in drivetrain	Remove pinion and check/repair as necessary
Motor/ESC Overheated	Over-gearred	Install smaller pinion
Doesn't Operate	Transmitter battery	Replace "AA" batteries
	Transmitter not on	Turn on
	ESC not on	Receiver not on
	Battery	Make sure battery is charged
Poor Range/ Glitches	Transmitter batteries low	Check/ replace
	Transmitter antenna loose	Check/tighten
	Battery Pack not charged	Charge and retry
	Receiver antenna cut/worn	Check/send in for repair
	Motor dirty/worn brushes	Check/clean/repair
	Loose plugs or wires	Check all plugs and wires



Parts Listing

Key#	Stock#	Description	Price	Key#	Stock#	Description	Price
1	SWK5200	Raven ST Body, Clear	\$17.99	31	SWK5058	Diff Pinion & Idler Shaft Set	\$3.99
2	SWK5201	Raven BX Painted Body, Red	\$29.99	32	SWK5060	Front/Rear Suspension Pin Brace Set	\$4.99
3	SWK5202	Raven BX Painted Body, Blue	\$29.99	33	SWK5062	Motor Plate	\$5.99
4	SWK5206	1/10 Multi Rib FR Buggy Tires Mntd	\$15.99	34	SWK5064	Slipper Plate	\$8.99
5	SWK5207	1/10 Mini Pin RR Buggy Tires Mntd	\$17.99	35	SWK5066	Transmission Main Shaft	\$6.99
6	SWK5216	Main Chassis Plate	\$12.99	36	SWK5250	Front Axles	\$3.99
7	SWK5010	Bulkhead/Kickplate Set	\$8.99	37	SWK5070	Ball Studs	\$5.99
8	SWK5218	Front Suspension Arms	\$4.99	38	SWK5072	Slipper Rebuild Kit	\$5.99
9	SWK5220	Rear Suspension Arms	\$4.99	39	SWK5074	4-40 Locknuts	\$3.99
10	SWK5222	Front Shock Tower	\$3.99	40	SWK5076	Body Clips	\$2.99
11	SWK5224	Rear Shock Tower	\$3.99	41	SWK5252	Camber/Steering Link Bag	\$9.99
12	SWK5020	Front/Rear Pivot Block Set	\$2.99	42	SWK5080	Shock Rod End Balls	\$3.99
13	SWK5022	Battery Hold-Down Strap	\$3.99	43	SWK5082	Rear Axle Drive Pins	\$4.99
14	SWK5024	Steering Blocks	\$2.49	44	SWK5084	Sealed Bearings 8x12x3.5mm	\$4.99
15	SWK5026	Front C-Hubs	\$2.99	45	SWK5086	Sealed Bearings 3/16x3/8	\$3.99
16	SWK5028	Rear Hubs	\$2.99	46	SWK5088	Sealed Bearings 3x6x2.5mm	\$3.99
17	SWK5030	Tranny Gear Bag	\$5.99	47	SWK5090	E-Clip Bag	\$0.99
18	SWK5230	Spur Gear 76T	\$2.99	48	SWK5263	23T Pinion Gear	\$2.99
19	SWK5034	Upper Shock Mount Bushings	\$2.99	49	SWK5094	Raven Screw Set (68pcs)	\$11.99
20	SWK5036	Servo Saver Plastic Parts	\$3.99	50	SWK5096	Shock Rebuild Kit	\$4.49
21	SWK5038	Transmission Case	\$3.99	51	SWK5098	Medium Shock Shafts	\$3.49
22	SWK5040	Chassis/Tranny Brace Set	\$5.99	52	SWK5244	Short Shock Shafts	\$3.49
23	SWK5042	Front Bumper/Motor Guard Set	\$3.99	53	SWK5102	Medium Shock Body Set	\$9.99
24	SWK5044	Gear Cover & Cap Set	\$3.99	54	SWK5246	Short Shock Body Set	\$9.99
25	SWK5046	Ball Cup Set	\$5.99	55	SWK5240	Short Shock Springs Silver	\$3.99
26	SWK5048	Rear Axles	\$5.99	56	SWK5242	Medium Shock Springs, Black	\$3.99
27	SWK5050	Diff Outdrive Set	\$5.99	57	SWK5248	Assembled Short Shock Set	\$19.99
28	SWK5254	Dogbones	\$7.99	58	SWK5110	Assembled Medium Shock Set	\$19.99
29	SWK5054	Servo Saver Metal Parts Set	\$5.99	59	SWK5226	Rear Body Post Set	\$3.99
30	SWK5056	Hinge Pin Set	\$5.99	60	SWK5207	Front Dish Wheel	\$3.99
				61	SWK5211	Rear Dish Wheel	\$4.99

Please see your favorite retailer or visit our web site (www.SportwerksRC.com) to find the latest in new replacement and option parts releases for your Raven™ BX.



Parts Breakdown

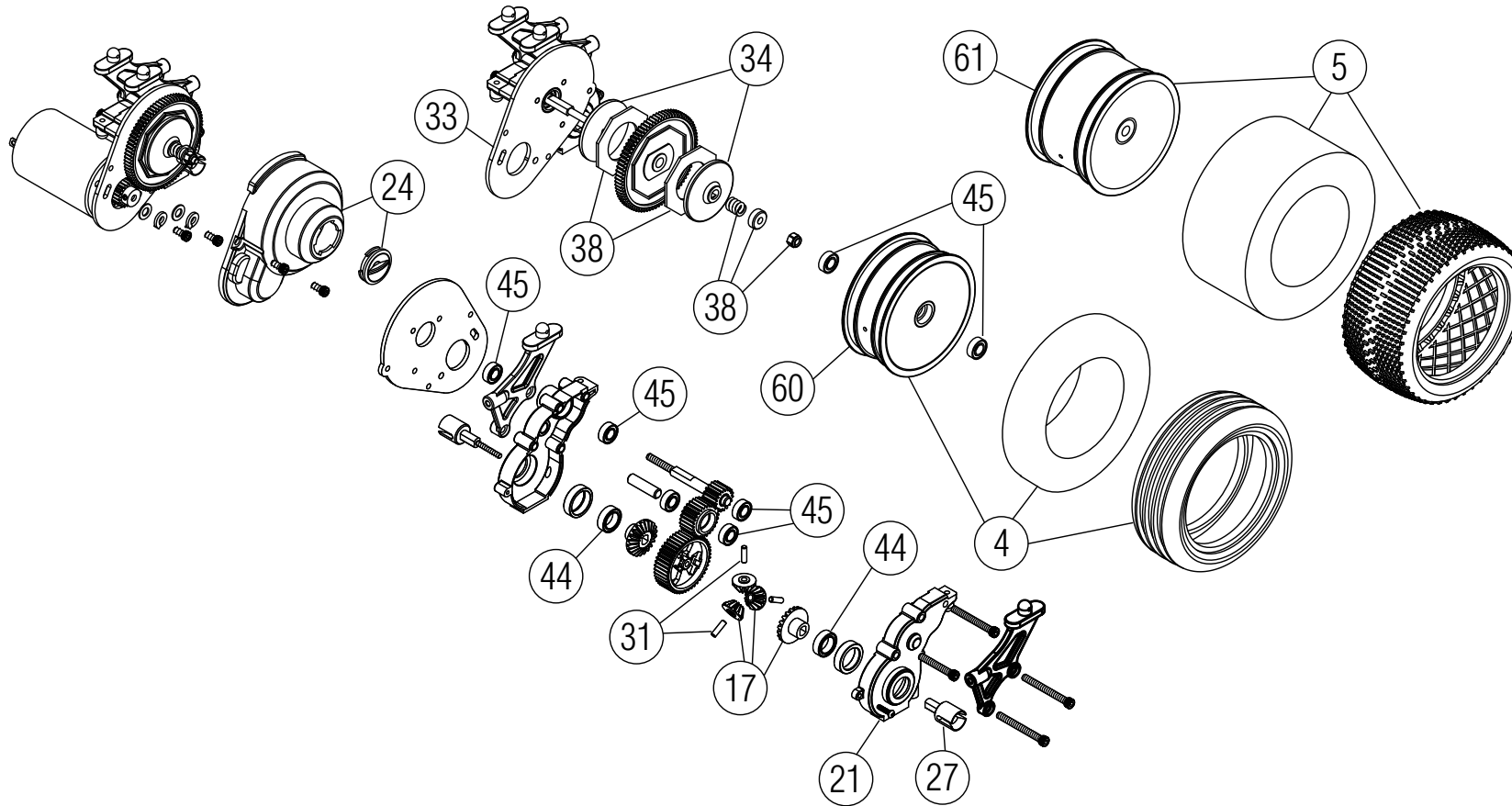

Note: All screws are included with Key #49 (Raven BX Screw Set)



Parts Breakdown

Note: All screws are included with Key #49 (Raven BX Screw Set)

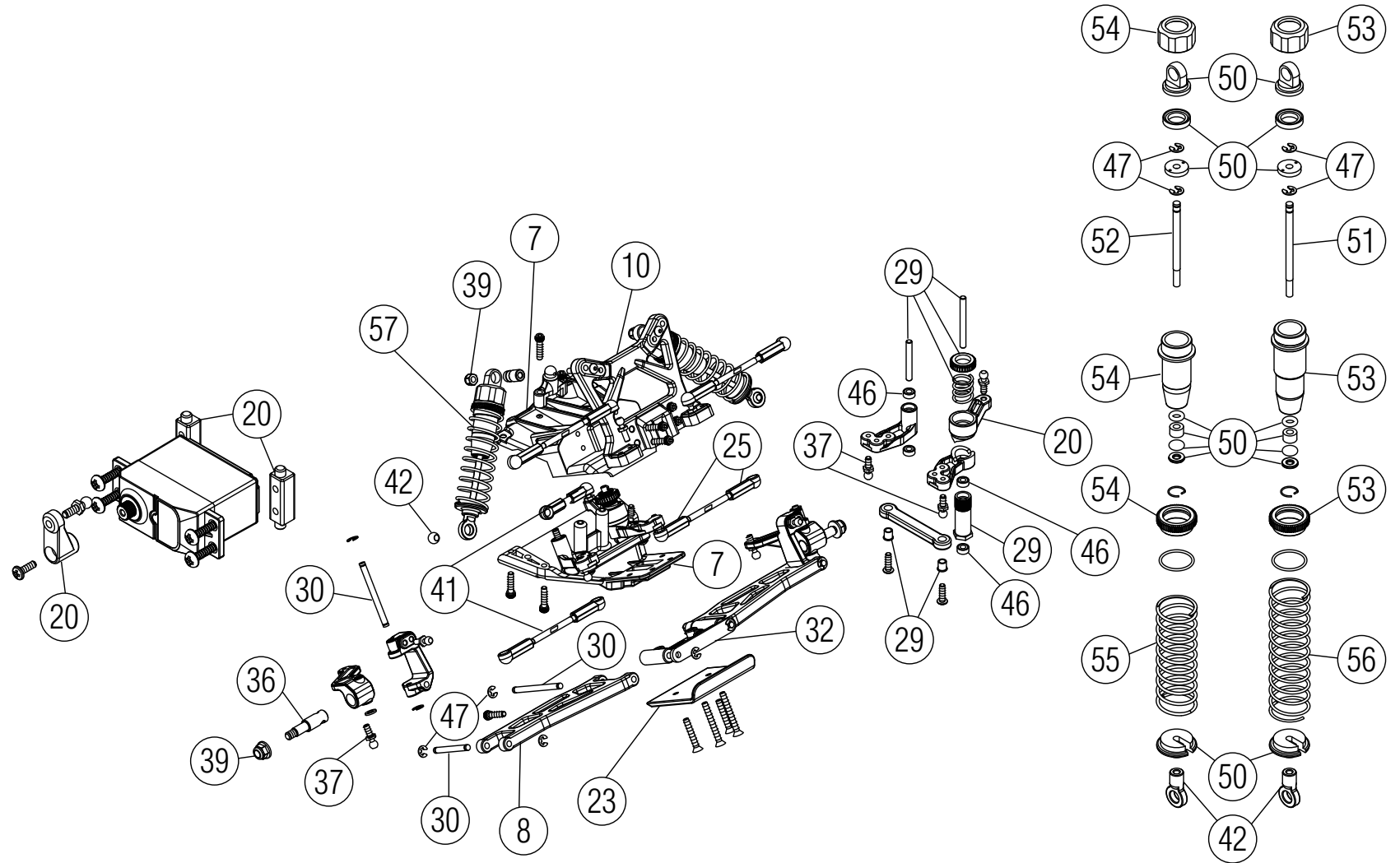

Parts Breakdown

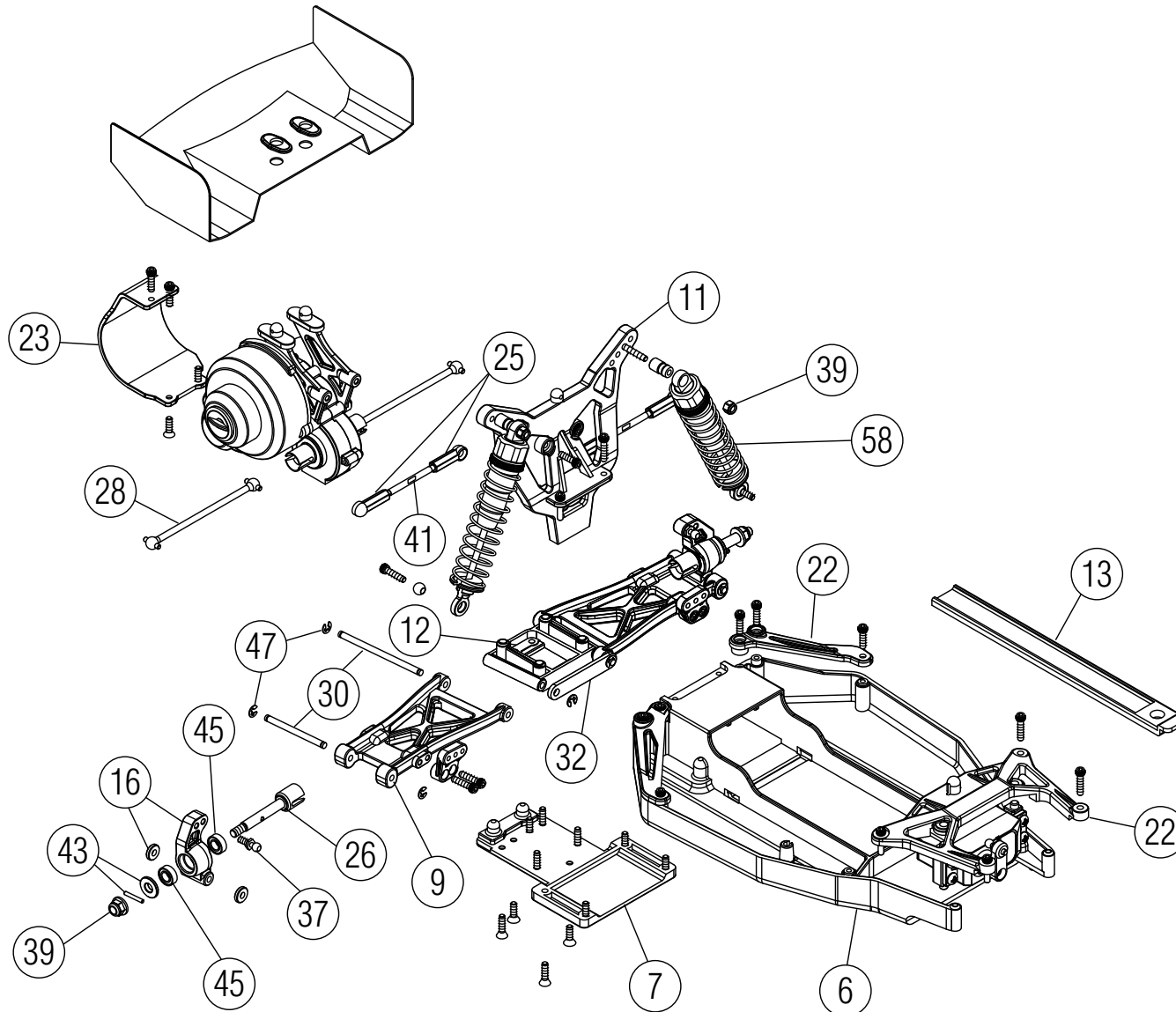

Note: All screws are included with Key #49 (Raven BX Screw Set)



HORIZON
H O B B Y

© 2006 Horizon Hobby, Inc.
4105 Fieldstone Road
Champaign, Illinois 61822
(877) 504-0233
www.horizonhobby.com