

FOUR CYCLE ENGINE OWNER'S INSTRUCTION MANUAL

It is of vital importance, before attempting to operate your engine, to read the general **'SAFETY INSTRUCTIONS AND WARNINGS'** section on pages 2-4 of this booklet and to strictly adhere to the advice contained therein. Also, please study the entire contents of this instruction manual, so as to familiarize yourself with the controls and other features of the engine.

- Keep these instructions in a safe place so that you may readily refer to them whenever necessary.

- It is suggested that any instructions supplied with the aircraft, radio control equipment, etc., are accessible for checking at the same time.

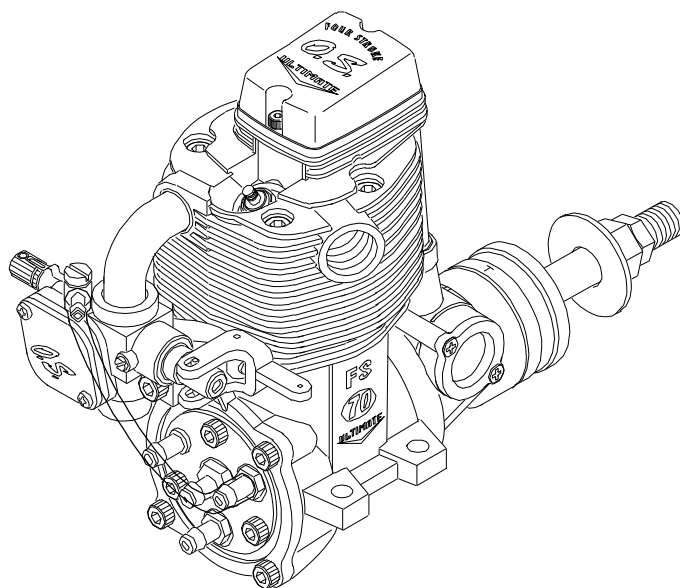

CONTENTS

SAFETY INSTRUCTIONS AND WARNINGS ABOUT YOUR O.S. ENGINE	2-4	RUNNING-IN	13-14
INTRODUCTION, INSTALLING THE GLOWPLUG	5	IDLE MIXTURE ADJUSTMENT CARE AND MAINTENANCE (laying up)	15
INSTALLATION	6	VALVE ADJUSTING HOW TO SET THE CAMSHAFT TIMING	16-17
FUEL TANK & LINES	7-8	CARE AND MAINTENANCE	18
EXHAUST HEADER PIPE AND SILENCER, THROTTLE LINKAGE, NEEDLE-VALVE EXTENSION	9	CARBURETOR EXPLODED VIEWS & PARTS LIST	19
CARE OF FUEL PUMP AND REGULATOR, PROPELLERS	10	ENGINE EXPLODED VIEWS & ENGINE PARTS LISTS	20-21
GLOWPLUGS, FUEL	11	O.S. GENUINE PARTS & ACCESSORIES	22
PROPELLER AND SPINNER ATTACHMENT, TYPE 60U CARBURETOR	12	ENGINE THREE VIEW DRAWINGS	23
STARTING	13	MEMO	24

SAFETY INSTRUCTIONS AND WARNINGS ABOUT YOUR O.S. ENGINE

Remember that your engine is not a "toy", but a highly efficient internal-combustion machine whose power is capable of harming you, or others, if it is misused or abused. As owner, you, alone, are responsible for the safe operation of your engine, so act with discretion and care at all times.

If at some future date, your O.S. engine is acquired by another person, we would respectfully request that these instructions are also passed on to its new owner.

- The advice which follows is grouped under two headings according to the degree of damage or danger which might arise through misuse or neglect.





WARNINGS

These cover events which might involve serious (in extreme circumstances, even fatal) injury.

NOTES

These cover the many other possibilities, generally less obvious sources of danger, but which, under certain circumstances, may also cause damage or injury.

WARNINGS

- ◆ Never touch, or allow any object to come into contact with, the rotating propeller and do not crouch over the engine when it is running. 
- ◆ A weakened or loose propeller may disintegrate or be thrown off and, since propeller tip speeds with powerful engines may exceed 600 feet(180 metres) per second, it will be understood that such a failure could result in serious injury, (see 'NOTES' section relating to propeller safety).
- ◆ Model engine fuel is poisonous. Do not allow it to come into contact with the eyes or mouth. Always store it in a clearly marked container and out of the reach of children. 
- ◆ Model engine fuel is also highly flammable. Keep it away from an open flame, excessive heat, sources of sparks, or anything else which might ignite it. Do not smoke or allow anyone else to smoke, near to it. 
- ◆ Never operate your engine in an enclosed space. Model engines, like automobile engines, exhaust deadly carbon-monoxide. Run your engine only in an open area.
- ◆ Model engines generate considerable heat. Do not touch any part of your engine until it has cooled. Contact with the muffler(silencer), cylinder head or exhaust header pipe, in particular, may result in a serious burn. 

2

NOTES

- ◆ This engine was designed for model aircraft. Do not attempt to use it for any other purpose.
- ◆ Mount the engine in your model securely, following the manufacturers' recommendations, using appropriate screws and locknuts.
- ◆ Be sure to use the silencer (muffler) supplied with the engine. Frequent exposure to an open exhaust may eventually impair your hearing. Such noise is also likely to cause annoyance to others over a wide area.
- ◆ Install a top-quality propeller of the diameter and pitch specified for the engine and aircraft. Locate the propeller on the shaft so that the curved face of the blades faces forward-i.e. in the direction of flight. Firmly tighten the propeller nut, using the correct size wrench.
- ◆ Always check the tightness of the propeller nut and retighten it, if necessary, before restarting the engine, particularly in the case of four-stroke-cycle engines. A safety locknut assembly is provided. Always use it. This will prevent the propeller from flying off in the event of a "backfire", even if it loosens.
- ◆ If you install a spinner, make sure that it is a precision made product and that the slots for the propeller blades do not cut into the blade roots and weaken them.
- ◆ Discard any propeller which has become split, cracked, nicked or otherwise rendered unsafe. Never attempt to repair such a propeller: destroy it. Do not modify a propeller in any way, unless you are highly experienced in tuning propellers for specialized competition work such as pylon-racing.
- ◆ Use an electric starter for this engine. The wearing of safety glasses is also strongly recommended.

3

! NOTES

- ♦ Take care that the glow plug clip or battery leads do not come into contact with the propeller. Also check the linkage to the throttle arm. A disconnected linkage could also foul the propeller.
- ♦ After starting the engine, carry out any needle-valve readjustments from a safe position behind the rotating propeller. Stop the engine before attempting to make other adjustments to the carburetor.
- ♦ Adjust the throttle linkage so that the engine stops when the throttle stick and trim lever on the transmitter are fully retarded. Alternatively, the engine may be stopped by cutting off the fuel supply. Never try to stop the engine physically.
- ♦ Take care that loose clothing (ties, shirt sleeves, scarves, etc.) do not come into contact with the propeller. Do not carry loose objects (such as pencils, screwdrivers, etc.) in a shirt pocket from where they could fall through the propeller arc.
- ♦ Do not start your engine in an area containing loose gravel or sand. The propeller may throw such material in your face and eyes and cause injury.
- ♦ For their safety, keep all onlookers (especially small children) well back (at least 20 feet or 6 meters) when preparing your model for flight. If you have to carry the model to the take-off point with the engine running, be especially cautious. Keep the propeller pointed away from you and walk well clear of spectators.
- ♦ **Warning!** Immediately after a glowplug-ignition engine has been run and is still warm, conditions sometimes exist whereby it is just possible for the engine to abruptly restart if the propeller is casually flipped over compression **WITHOUT** the glowplug battery being reconnected. Remember this if you wish to avoid the risk of a painfully rapped knuckle!

4

INTRODUCTION

The FS-70 ULTIMATE comes equipped with the new O.S. FS-70U diaphragm type fuel pump and matching Type 60U carburetor incorporating a built-in pressure regulator. These features ensure that fuel/air mixture strength is maintained at a constant level through maneuvers, for consistent performance and reliable throttle response.

In the interests of improved durability, certain ferrous parts that are particularly susceptible to corrosion in four-stroke engines, have a corrosion resistant plating and, for the same reason, a special grease-packed twin-sealed rear ball-bearing is used.

To maintain the four-stroke engine's reduced noise levels, the FS-70 ULTIMATE is supplied with an O.S. Type F-4020 baffled silencer (muffler) of substantially enlarged volume, as standard equipment.

Where installation calls for a separate exhaust pipe, these parts are available as optional extras.

INSTALLING THE GLOW PLUG

Carefully insert plug, with washer, fingertight only, before final tightening with the correct size wrench.

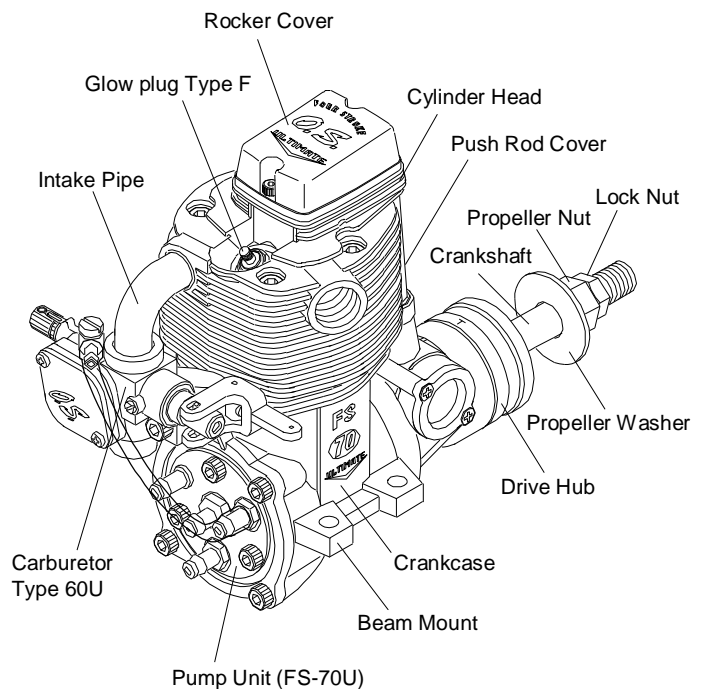
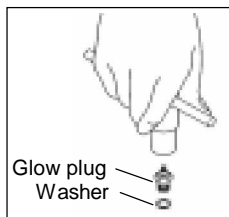

5

INSTALLATION

Because the FS-70 ULTIMATE is a powerful, large-displacement, single-cylinder four-stroke-cycle engine, it is essential to use very substantial engine mounting. Conventional wooden mounting beams should be of rigid hardwood and of at least 15mm or 5/8-in square section.

Make sure that these mounting beams are accurately aligned and firmly integrated with the airframe, reinforcing the adjacent structure to absorb vibration. Use 3mm or larger steel screws, preferably Allen type hexagon socket head cap screws, with washers and locknuts, for bolting the engine to the bearers.

Make sure that the mounting beams are parallel and that their top surfaces are in the same plane.

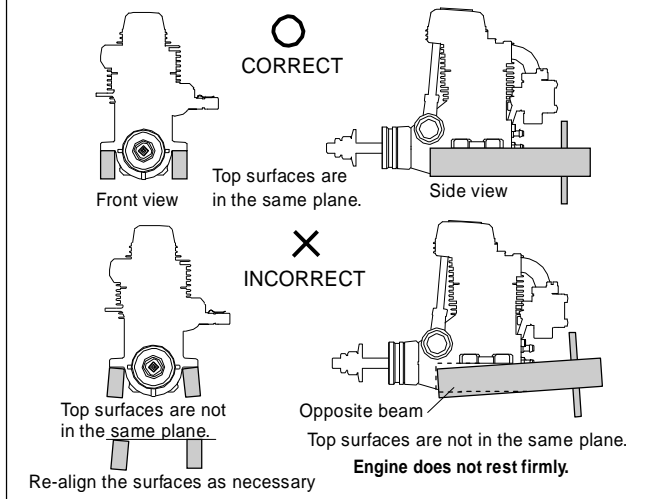

How to fasten the mounting screws.

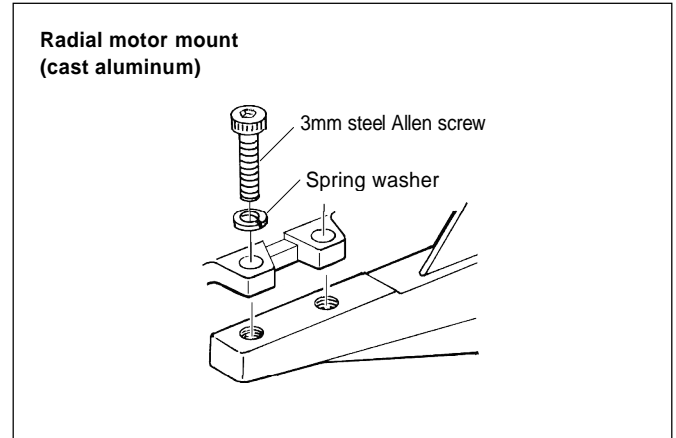
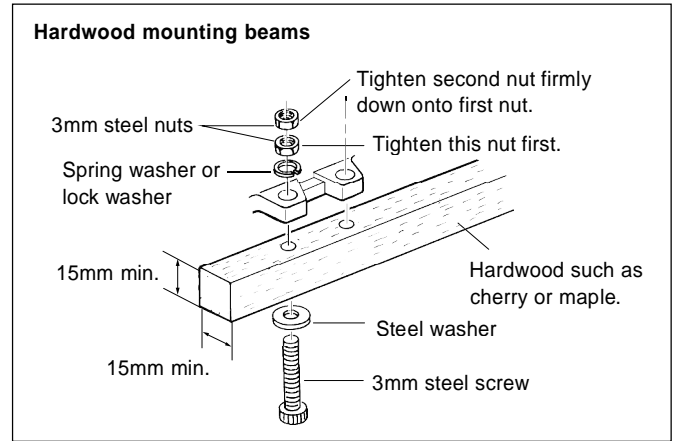

FUEL TANK & LINES

- ◆ A fuel tank of approximately 300cc capacity is suggested. This allows up to 12-13 minutes flying time, dependent upon the type of fuel used, the size of the propeller and on the proportion of full-throttle to part-throttle operation through the flight.
- ◆ Make sure that the tank is well rinsed out with methanol or glow fuel before installation and that the pickup weight is well clear of the bottom of the tank when held vertically (see sketch).

- ◆ To prevent the pickup from adhering to the tank wall under suction and restricting fuel flow, slots may be filed in the end of the weight as shown. Alternatively, a Non-Bubble type weight (Code No. 71531000) may be used.
- ◆ Since high pressure is applied to the fuel tank from the engine crankcase, use a thick-walled strong enough tank and securely seal the area around the cap.

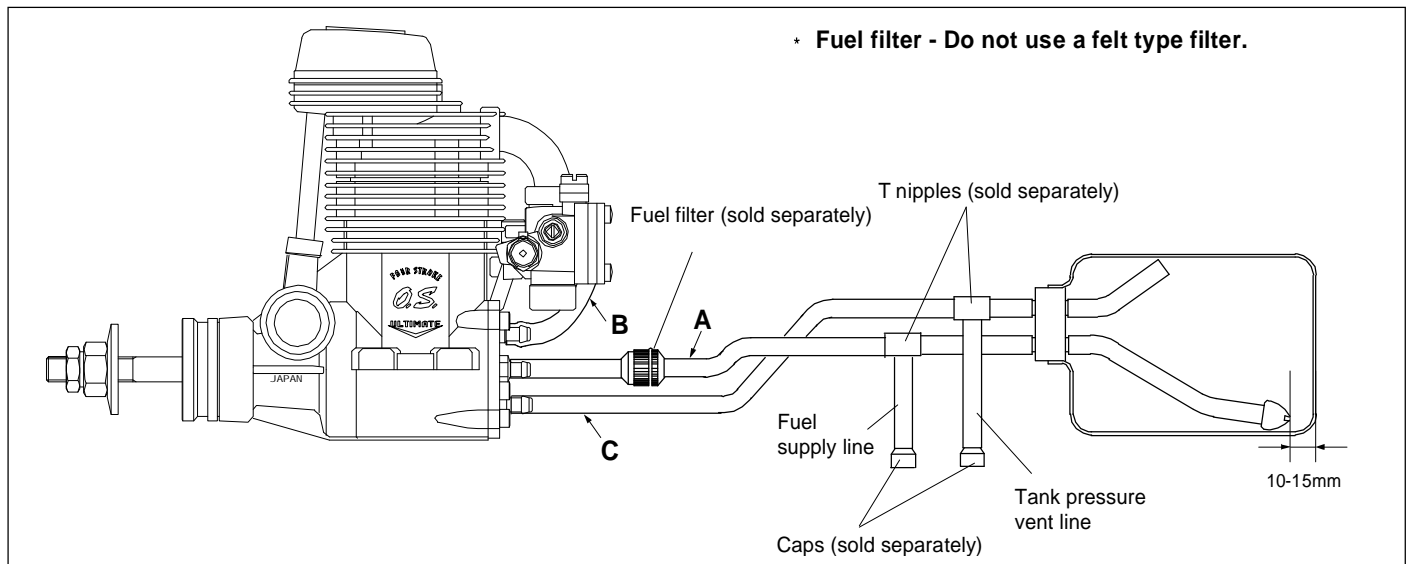

- ◆ Make connections using a commercially available thick-walled silicone tubing of approximately 2.5mm bore and 5.0mm outside diameter. It is suggested that tube clips be used at all connections.

The function of the various tubing connected to the engine and tank (see sketch) are as follows:

Line A: To draw fuel from tank to pump (IN)

Line B: To deliver fuel from pump to carburetor (OUT)

Line C:

Line D: To pressurize fuel tank.

Air intake pipe to take air into the crankcase, not a breather. Be careful not to let the dirt and dust in. Tube length should be less than 150mm.

Important

Lines B is already installed when the engine is shipped from the factory. If any of these lines should need to be replaced, due to damage or installation problems, be sure to use tubing of the same dimensions and quality as the originals. The length of Line B is approx 65mm.

Note: Since the FS-70 ULTIMATE has a positively pumped fuel supply, it does NOT require muffler pressurization.

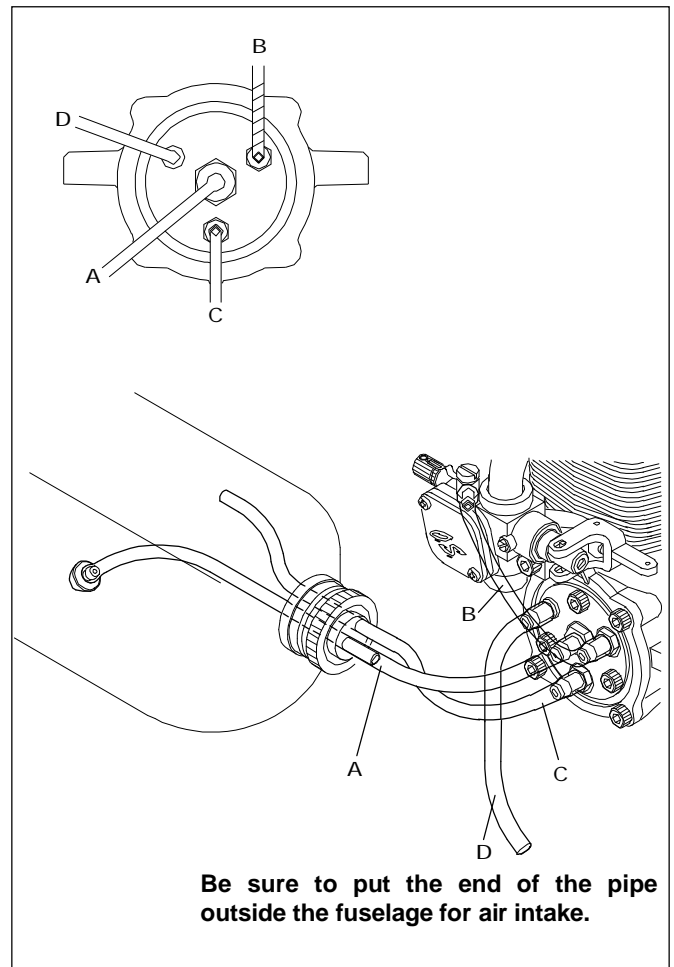

8

EXHAUST HEADER PIPE & SILENCER

Install these in the following sequence.

Screw the header pipe into the cylinder head until it "bottoms", then unscrew sufficiently to achieve the desired exhaust angle and tighten the locknut securely with a 14mm wrench. Screw the silencer onto the outer end of the header pipe and tighten the other locknut.

The application of a heatproof silicone sealant to the threads of the exhaust system is recommended to reduce the risk of joints loosening and the leakage of exhaust gases and oil residue.

Reminder:

Model engines generate considerable heat and contact with the header pipe or silencer may result in a serious burn. If you need to tighten the silencer joints, which may loosen when they are hot, use a thick folded cloth for protection.

THROTTLE LINKAGE

Before connecting the throttle to its servo, make sure that the throttle arm and linkage safely clear any adjacent part of the airframe structure, etc., as the throttle is opened and closed. Connect the linkage so that the throttle is fully closed when the transmitter throttle stick and its trim lever are at their lowest settings and fully open when the throttle stick is in its fully-open position..

Carefully align the appropriate holes in the throttle arm and servo horn so that they move symmetrically and smoothly through their full travel.

Note:

The engine is equipped a slide valve carburetor which has a narrower movement between fully closed and fully open. Secure the throttle lever linkage so that it may not move with vibration.

NEEDLE-VALVE EXTENSION

The needle-valve supplied with this engine is designed to incorporate an extension so that, when the engine is enclosed within the fuselage, the needle-valve may be adjusted from the outside.

Cut a commercially available rod to the required length, bend one end to an L shape, insert it into needle's center hole and secure it by tightening the set-screw in the needle-valve knob with 1.5mm Allen key.

Needle Valve Extension Cable Set (Code No. 72200080) is available from O.S. as an optional part.

9

CARE OF FUEL PUMP & REGULATOR

- ◆ NEVER disassemble the fuel pump or pressure regulator. Their original performance may not be restored after reassembly.
- ◆ DO NOT allow foreign matter to enter the fuel system. Dirt inside the pump or regulator, no matter how small, may obstruct the flow of fuel and prevent these components from working properly.
- ◆ DO NOT obstruct the small rectangular hole at the bottom of the regulator, nor the regulator will not function correctly.
- ◆ NEVER insert anything into the inlet or outlet nipples in an attempt to clear a suspected obstruction. (See CARE & MAINTENANCE section at the back of this booklet.)
- ◆ ALWAYS use fuel filters. Keep the fuel tank scrupulously clean and filter all fuel as it enters the tank (e.g. via an O.S.'Super-Filter' Code No.72403050) and use a good quality in-line filter between the tank and pump. Remember to inspect filter screens at regular intervals and rinse clean as necessary.
- ◆ NEVER use gasoline, kerosene, diesel fuel or other petroleum products for cleaning the pump, regulator or fuel lines. Silicone-rubber parts will be ruined by these materials. Use only alcohol (methanol) or glow fuel for cleansing these items.

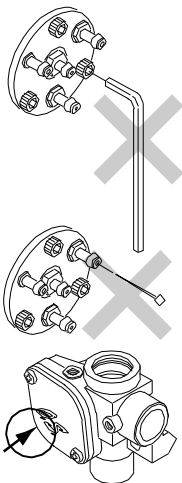

Note:

If you find noticeable amount of oil coming out into the pump Line D and the engine cannot be adjusted correctly, please return the whole engine to the distributor in your country or direct to O.S.

PROPELLERS

The choice of propeller depends on the design and weight of the aircraft and on the type of flying in which you will be engaged. Determine the best size and type after practical experimentation.

As a starting point, refer to the props listed in the accompanying table.

Slightly larger, or even slightly smaller, props than those shown in the table may be used, but remember that propeller noise will increase if blade tip velocity is raised, due to higher rpm or if a larger-diameter / lower-pitch prop is used.

Warning:

Make sure that the propeller is well balanced. An unbalanced propeller and / or spinner can cause serious vibration which may weaken parts of the airframe or affect the safety of the radio-control system.

DO NOT forget the WARNINGS and NOTES on propeller and spinner safety given on pages 2,3 and 4.

Type	Size (DxP)
Sport & Stunt models	13x7-8
Aerobatic models	13x6

10

GLOWPLUGS

The FS-70 ULTIMATE is supplied with an O.S. Type F glowplug, specially designed for O.S. four-stroke engines.

The role of the glowplug

With a glowplug engine, ignition is initiated by the application of a 1.5-volt power source. When the battery is disconnected, the heat retained within the combustion chamber remains sufficient to keep the plug filament glowing, thereby continuing to keep the engine running. Ignition timing is 'automatic' : under reduced load, allowing higher rpm, the plug becomes hotter and, appropriately, fires the fuel/air charge earlier; conversely, at reduced rpm, the plug becomes cooler and ignition is retarded.

Glowplug life

Particularly in the case of very high performance engines, glowplugs must be regarded as expendable items.

However, plug life can be extended and engine performance maintained by careful use, i.e.:

- ◆ Install a plug suitable for the engine.
- ◆ Use fuel containing a moderate percentage of nitromethane unless more is essential for racing events.
- ◆ Do not run the engine too lean and do not leave the battery connected while adjusting the needle.

When to replace the glowplug

Apart from when actually burned out, a plug may need to be replaced because it no longer delivers its best performance, such as when:

- ◆ Filament surface has roughened and turned white.
- ◆ Filament coil has become distorted.

- ◆ Foreign matter has adhered to filament or plug body has corroded.
- ◆ Engine tends to cut out when idling.
- ◆ Starting qualities deteriorate.

FUEL

The FS-70 ULTIMATE should be operated on a methanol based fuel containing not less than 18% castor-oil, or a top quality synthetic lubricant (or a mixture of both), plus a small percentage (5-30%) of nitromethane for improved flexibility and power. The carburetor is adjusted at the factory for a fuel containing 20% lubricant and 15% nitromethane.

Some commercial fuels also contain coloring additives as an aid to fuel level visibility. In some cases, these additives have indicated slightly negative effects on performance. We would suggest that you use such fuels only if you are satisfied that they do not adversely affect running qualities when compared with familiar standard fuels.

When changing to a fuel brand or formula that is different from the one to which you are accustomed, it is a wise precaution to temporarily revert to in-flight running-in procedures, until you are sure that the engine is running entirely satisfactorily.

Reminders:

All model engine fuel is poisonous. Do not allow it to come into contact with the eyes or mouth. Always store it in a clearly marked container and out of the reach of children.

Though not as volatile as gasoline, model engine fuel is also highly inflammable. Keep it away from an open flame, excessive heat, sources of sparks, or anything else that might ignite it. Smoking is firmly discouraged.

11

PROPELLER & SPINNER ATTACHMENT

There is a risk, particularly with powerful four-stroke engines, of the propeller flying off if the prop nut loosens due to detonation ("knocking") in the combustion chamber when the engine is operated too lean, or under an excessively heavy load.

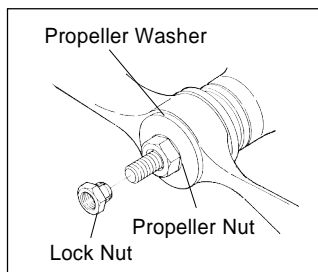

Obviously, this can be very hazardous. To eliminate such dangers, the O.S. Safety Locknut Assembly was devised. Install this as follows:

1. Ream the propeller shaft hole to 6.5mm bore with an appropriate reamer, checking that the hole is exactly centered.
 2. Install the prop to the engine shaft, followed by the retaining washer and prop nut and tighten firmly with a 12mm wrench.
 3. Add the special tapered and slotted locknut and secure with a 10mm wrench while holding the prop nut with the 12mm wrench.
- ♦ Spinners retained by a nose bolt cannot be used with this Locknut.

Since the FS-70 ULTIMATE is intended to be started with an electric starter, the addition of a spinner assembly for centering the starter sleeve is desirable. In this case, optional locknut sets are available from O.S. Propeller Locknut Set for Spinner (Code No. 45810200) Propeller Locknut Set for Tru Turn Spinner (Code No. 45810300).

TYPE 60U CARBURETOR

Two adjustable controls are provided on these carburetors. They are as follows:

♦ The Needle Valve

This is used to establish the fuel/air mixture strength required for full power when the throttle is fully open.

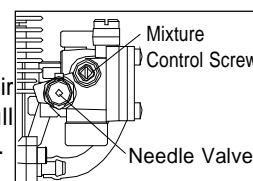

♦ The Mixture Control Screw

This is used to establish the mixture strength required for steady idling and a smooth transition to medium speeds. (The varying mixture strength required between part-throttle and full-throttle running is automatically adjusted by coupled movement of the throttle.)

The sequence in which these controls are adjusted is explained in the succeeding sections, under Starting, Running-in and Idling Adjustment.

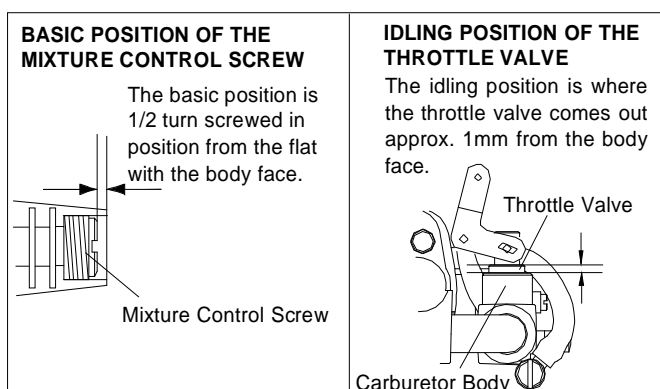

12

STARTING

The FS-70 ULTIMATE is not equipped with manual choke controls, as they are intended for use with an electric starter only. A high-torque electric starter not only makes starting the engine much easier, it dispenses with the need for a choke valve by turning the engine over fast enough to cause the fuel pump to prime the cylinder automatically.

Starting procedure is as follows:

1. Check that the current to the glowplug is switched off.
2. Check that the polarity of the starter battery leads rotates the engine counter-clockwise when viewed from the front.
3. Open the needle-valve approx. 2 turns from the fully closed position and temporarily set the throttle in the fully open position.
4. Apply the starter and press the starter switch for 5-6 seconds, or until fuel is seen to emerge from the exhaust outlet, indicating that the cylinder is now primed.
5. Close the throttle-arm to within 15-20° of the fully closed position and slowly turn the prop "backwards" (clockwise) by hand until it is arrested by compression. This is to enable the kinetic energy of the prop to subsequently assist the starter through the compression stroke to start the engine.
6. Energize the glowplug and apply the starter. If the starter fails to rotate the engine completely, this may be due to the cylinder being over-primed, or to the starter battery being insufficiently charged.

7. Check these conditions and, instead of pressing the starter button after applying the starter, have the starter spinning before applying it to the engine, to give it a "running start". When the engine starts, slowly open the throttle, leaving the needle-valve at its rich starting setting to promote cool running conditions.

However, if the engine slows down because the mixture is excessively rich, the needle-valve may be closed a little to speed it up until it runs evenly.

8. Now disconnect current to the glowplug and gradually close the needle-valve so that the engine rpm increases. Make adjustments to the needle in small steps. Abrupt changes at this stage are likely to cause the engine to stall. Restart the engine by simply applying the starter with the glowplug re-energized and the throttle at its starting setting.

RUNNING-IN ("Breaking-in")

For long life and peak performance, every engine needs special treatment when new, known as "running-in" or "breaking-in". This is a process during which the engine is operated under strictly controlled conditions at the beginning of its life, in order to avoid the risk of immediate damage to certain components through becoming overheated or stressed and to help working surfaces to become smoothed and aligned for maximum mechanical efficiency thereafter.

With some engines, this can require a tediously protracted period of bench running, but, as O.S. engines are manufactured to fine tolerances and from the finest quality materials, a relatively brief running-in period is sufficient and can be completed with the engine installed in the aircraft.

The recommended procedure is as follows :

13

1. Start and adjust the engine as detailed in the starting instructions.
2. Now open the throttle fully and run the engine with the condition of emitting a good deal of white smoke.
3. Open the needle-valve gradually to increase r.p.m., then close the needle-valve gradually to lower r.p.m. Repeat this procedure until two to three full tanks of fuel have been consumed so that r.p.m. may come close to peak.
4. Then, proceed IDLE MIXTURE ADJUSTMENT mentioned in the next page.

WARNING:

When ground running the engine, avoid dusty or sandy locations. If dust or grit is drawn into the engine, this can have a ruinous effect, drastically shortening engine life in a matter of minutes.

5. Following the initial running-in session, check for any looseness in the installation due to vibration, then allow the engine a period of moderately rich operation in flight.
6. For the first flight, have the needle-valve set on the rich side and adjust the throttle trim on the transmitter so that the engine does not stop when the throttle is closed to the idle setting.
7. With each successive flight, close the needle-valve very slightly until, at the end of about 10 flights, the needle is set for full power. Do not "over-lean" the mixture in an attempt to extract more power.

8. If overheating should be suspected at any time during flight (i.e. if the engine begins to "labor") reduce power by partially closing the throttle and land the aircraft to enable the needle-valve to be readjusted to a richer setting.

Note:

Remember that, when the engine is not yet fully run-in, the carburetor cannot be expected to give its best response in flight. Abrupt operation of the throttle, for example, may cause the engine to stall. Therefore, at this time, the aircraft should, as far as is possible, be flown at an altitude sufficient to enable an emergency landing to be safely made if the engine stops.

9. Once the engine has demonstrated that it can be safely operated at full power, the carburetor can be adjusted for optimum throttle response, following the instructions given in the next section.

IDLE MIXTURE ADJUSTMENT

1. Start the engine, open the throttle fully and set the needle-valve slightly rich (30-45°) from the highest r.p.m. setting.
2. Close the throttle to the idle position. Allow the engine to idle for about 5 seconds, then reopen the throttle. The engine should accelerate smoothly back to full speed.
3. If, instead, the engine responds sluggishly and emits an excess of white smoke from the exhaust, the idle mixture is too rich. Turn the mixture control screw approx. 45° clockwise to lean the idle mixture.
4. On the other hand, if the engine hesitates before picking up speed or even ceases firing completely, the idle mixture is likely to be too lean. Turn the mixture control valve 90° counter-clockwise to substantially enrich the mixture, then back again 45° clockwise.
5. In paragraphs 3 and 4 above, the 45° total movements are, of course, approximate. It will be necessary to fine-tune the mixture control screw 10-15° at a time to reach the best setting for optimum throttle response.
6. Continue re-checking the idle mixture setting until the engine responds smoothly and positively to operation of the throttle at all times.

NOTE:

The use of a different fuel, particularly one containing more, or less, nitromethane and/or a different type or proportion of lubricating oil, is likely to call for some readjustment of the Needle-Valve.

Remember that, as a safety measure, it is advisable to increase the Needle-Valve opening by an extra half-turn counter-clockwise, prior to establishing a new setting. A different silencer may alter the exhaust pressure applied to the fuel feed and call for a revised Needle-Valve setting. The use of a different glowplug may also require compensating carburetor readjustments.

CARE & MAINTENANCE (laying up)

The fuel pump assembly, carburetor/pressure-regulator and silicone tubing must be cleansed separately in methanol or glow fuel. On no account must they come into contact with kerosene.

Before completely reassembling the engine, make sure that no kerosene remains inside that could find its way into the pump unit, carburetor, etc. Inject, sparingly, preserving oils, rust inhibitors, etc. unless approved for silicone-rubber products.

An appropriate alternative here may be one of the high-quality synthetic lubricating oils.

Finally, seal the engine in a heavy polyethylene bag until required for reinstalling in the airframe.

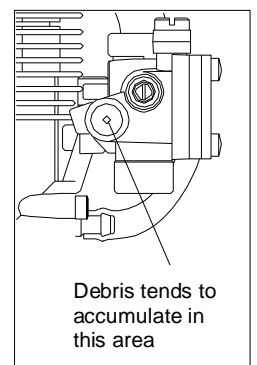

VALVE ADJUSTING

Valve clearances are correctly set before any O.S. engine leaves the factory and, in normal use, will seldom require adjustment. However, if, after a very considerable amount of running time, a loss of power is detected, or if the engine has been disassembled for repair, these clearances should be checked and reset as necessary.

The kit comes in a plastic case and includes:
(Code No.72200060)

- Feeler gauge 0.04mm
- Hex. key 1.5mm
- Feeler gauge 0.1mm
- Wrench 5mm

Note:

Valve clearances of all O.S. four-stroke-cycle engines must be checked and reset ONLY WHEN THE ENGINE IS COLD. Procedure is as follows.

(I)

1. Remove the cover from the rocker-box on top of the cylinder-head, using the correct size Allen hex key.
2. Turn the propeller counter-clockwise until compression is first felt, then turn it a further quarter revolution. At this point, both valves should be closed. (If the prop driver ('drive hub') of your engine is engraved with a letter 'T', this mark should now be at the top.)
3. The standard valve clearance, on both inlet and exhaust valves, is between 0.04mm and 0.10mm (0.0015-0.004 inch), measured between valve stem and rocker arm. Use the 0.04mm and 0.10mm feeler gauges to check clearances. (See Fig.1.)

Note:

If the gap is found to be less than 0.04mm, it is not necessary to readjust the clearance if the engine has good compression and starts easily.

Equally, if the gap exceeds 0.10mm but is not more than 0.14mm (i.e. the thickness of both feeler gauges inserted together), it is not essential to readjust the clearance if the engine runs satisfactorily.

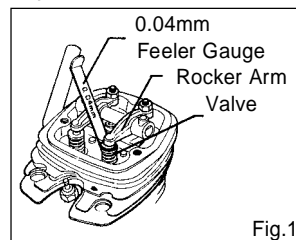

Fig.1

(II) If a clearance is found to be outside either of these limits, it should be reset as follows.

1. Carefully loosen the locknut on rocker-arm 1/4-1/2 turn with 5mm wrench. (Fig.2.)

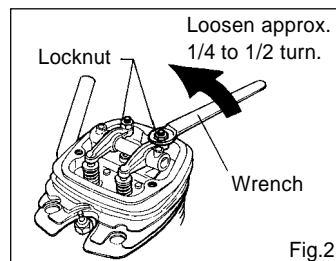

Fig.2

2. Turn adjusting-screw approx. 1/2 turn counter-clockwise to open gap, using appropriate tool - i.e. Allen hex key. (Fig.3.)

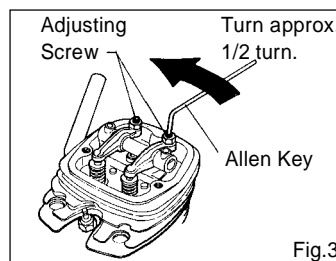
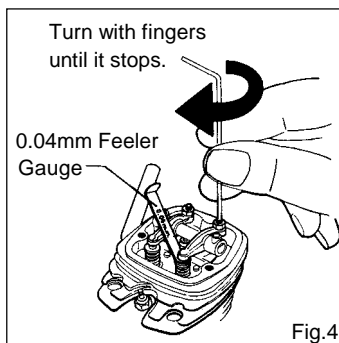

Fig.3

16

3. Insert 0.04mm feeler gauge between valve stem and rocker-arm and gently turn adjusting screw clockwise until it stops. (Fig.4.)



4. Re-tighten locknut while holding adjusting screw stationary. (Fig.5.)

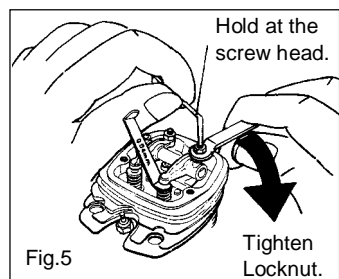

5. Remove 0.04mm feeler, rotate prop through two revolutions and recheck gap.

6. If clearance is correct, loosen the locknut on the other rocker-arm and repeat steps 1 to 5 above. Finally, replace rocker box cover.

Remember:

Excessive valve clearance will cause loss of power, due to valve (s) not opening sufficiently. On the other hand, a total loss of clearance may cause difficult starting due to valves not closing properly, resulting in loss of compression.

HOW TO SET THE CAMSHAFT TIMING

When replacing the camshaft, set the timing as follows.

1. Secure propeller.

NOTE:

If propeller is not secured, crankshaft may move backward and correct timing cannot be set.

2. Turn the crankshaft so that 'T' mark on the drive hub may match crankcase center line. (This is engine T.D.C. position)
3. Push the camshaft into camshaft housing until it stops. Locate '♦' mark on the side of camshaft gear in line with the push rod.
4. Rotate crankshaft right and left a little and make sure that the '♦' mark on the gear is in line with the push rod when the 'T' mark on the drive hub matches the crankcase center line.
5. Secure cam cover with screws.

The relation of position between '♦' mark of the gear and teeth may differ from the sketch, by each model.

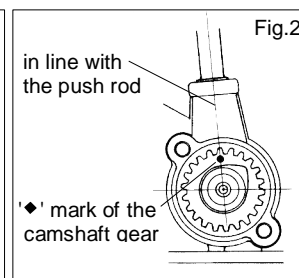
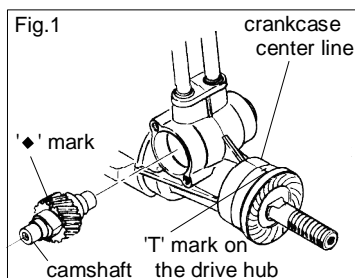

17

CARE AND MAINTENANCE

Please pay attention to the matters described below to ensure that your engine serves you well in regard to performance, reliability and long life.

As previously mentioned, it is vitally important to avoid operating the engine in conditions where dust, disturbed by the propeller, may be deposited on the engine and enter its working parts. Also, remember to keep your fuel container closed to prevent foreign matter from contaminating the fuel.

Do not forget to clean the fuel filters periodically and, from time to time, unscrew the complete needle-valve assembly from the carburetor and remove any foreign matter that has accumulated in this area. (See photo.)

If these precautions are neglected, restriction of fuel flow may cause the engine to cut out, or the fuel/air mixture to become too lean causing the engine to overheat.

The use of modern high-performance alcohol based model engine fuels, while promoting cooler running, improved anti-detonation combustion and increased power, have the disadvantage of causing bottom end corrosion in a four-stroke engine. This is due to the acidic by products of combustion that accumulate in the engine's crankcase and are not flushed out by fresh air/fuel mixture as in the case of a two-stroke engine. The use of nitromethane in the fuel can also contribute to the problem. As noted earlier, the FS-70 ULTIMATE has its most vulnerable components protected against such attack but, as a primary defence, users are advised, once again, to avoid running the engine on too lean a mixture and by making sure that the engine is purged of contaminants as much as possible.

Do not leave unused fuel in the engine at the conclusion of a day's flying. Accepted practice is to cut off the fuel supply while the engine is still running - at full throttle - then, expel as much fuel residue as possible by turning the engine over for 5-10 seconds with the electric starter.

Finally, inject some after-run oil through the glowplug hole and turn the engine over several times by hand.

When the engine is not to be used for some months (for example, as between flying seasons) a worthwhile precaution is to remove it from the airframe and, after washing off the exterior with alcohol (not gasoline or kerosene) to carefully remove the fuel pump, carburetor with intake pipe and all silicone tubing and put them safely aside.

Make sure that the engine is reasonably clean externally, then remove the glowplug and immerse the engine in a container of kerosene. Rotate the crankshaft while the engine is immersed. If foreign matter is visible in the kerosene, rinse the engine again in clean kerosene, before removing it, vigorously shaking off the excess and wiping it dry.

CARBURETOR EXPLODED VIEW & PARTS LIST

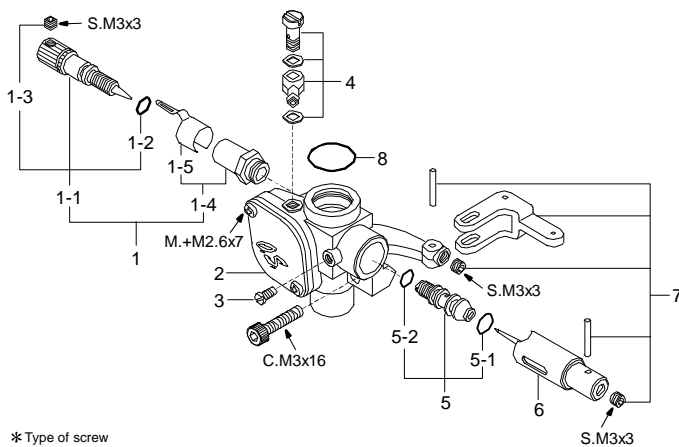

* Type of screw

C...Cap Screw M...Oval Fillister-Head Screw

F...Flat Head Screw N...Round Head Screw S...Set Screw

No.	Code No.	Description
1	25581900	Needle Valve Assembly
1-1	22681980	Needle Assembly
1-2	24981837	"O" Ring (2pcs.)
1-3	26381501	Set Screw
1-4	27381940	Needle Valve Holder Assembly
1-5	26711305	Ratchet Spring
2	44781100	Carburetor Body
3	21285220	Rotor Guide Screw
4	45571000	Universal Nipple S3.5
5	44781650	Mixture Control Valve Assembly
5-1	46066319	"O" Ring (L) (2pcs.)
5-2	24881824	"O" Ring (S) (2pcs.)
6	44781200	Slide Valve
7	44781400	Throttle Lever Assembly
8	45515000	Carburetor Rubber Gasket

The specifications are subject to alteration for improvement without notice.

EXPLODED VIEW

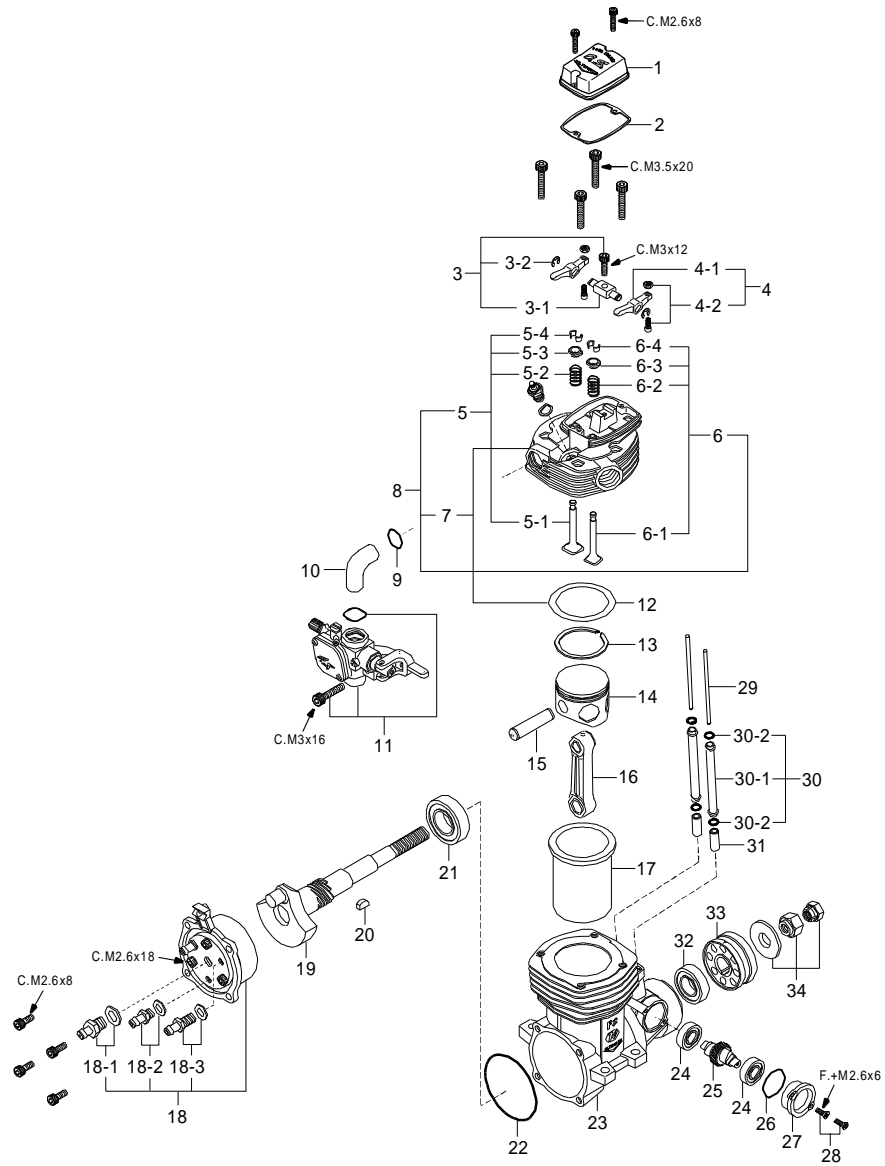

* Type of screw
 C...Cap Screw M...Oval Fillister-Head Screw
 F...Flat Head Screw N...Round Head Screw S...Set Screw

PARTS LIST

No.	Code No.	Description
1	44704200	Rocker Cover
2	44714300	Rocker Cover Gasket
3	45961400	Rocker Support Assembly
3-1	45961410	Rocker Support
3-2	45761600	Rocker Arm Retainer (2pc. /1pair)
4	44753000	Rocker Arm Assembly (1pair)
4-1	44753100	Rocker Arm (1pc.)
4-2	45761200	Tappet Adjusting Screw (w/nut)
5	44750000	Intake Valve Assembly (1pair)
5-1	44750100	Intake Valve (1pc.)
5-2	45960210	Valve Spring (1pc.)
5-3	45960310	Valve Spring Retainer (1pc.)
5-4	45960400	Split Cotter (2pc. /1pair)
6	44751000	Exhaust Valve Assembly (1pair)
6-1	44751100	Exhaust Valve (1pc.)
6-2	45960210	Valve Spring (1pc.)
6-3	45960310	Valve Spring Retainer (1pc.)
6-4	45960400	Split Cotter (2pc. /1pair)
7	44704100	Cylinder Head (w/Gasket)
8	44704000	Cylinder Head (w/Gasket and valve Assembly)
9	45515000	Intake Pipe Gasket
10	44769400	Intake Pipe
11	44781000	Carburetor Complete (Type 60U)
12	44714100	Head Gasket
13	29503400	Piston Ring
14	44703200	Piston
15	45906000	Piston Pin
16	44705000	Connecting Rod
17	44703100	Cylinder Liner

No.	Code No.	Description
18	44782000	Pump Unit (FS-70U)
18-1	44782160	Nipple No.16
18-2	45771000	Nipple No.5
18-3	22681957	Nipple No.7
19	44702000	Crankshaft
20	27708200	Woodruff Key
21	44230000	Crankshaft Ball Bearing (R)
22	44714200	Pump Holder Gasket
23	44701000	Crankcase
24	45231100	Camshaft Ball Bearing (1pc.)
25	44762000	Camshaft
26	44714400	Cam Cover Gasket
27	44701100	Cam Cover
28	44701109	Cam Cover Retaining Screw (2ppcs.)
29	44766000	Push Rod (2pcs.)
30	44766100	Push Rod Cover Assembly (2pcs.)
30-1	44766110	Push Rod Cover (1pc.)
30-2	24881824	Push Rod Cover "O" Ring (2pcs.)
31	45664000	Cam Follower (2pcs.)
32	44731000	Crankshaft Ball Bearing (F)
33	44708000	Drive Hub
34	45810100	Locknut Set
	71615009	Glow Plug Type F
	45925050	F-4020 (U) Silencer Assembly
	45925100	F-4020 Silencer Body
	45926100	Exhaust Header Pipe Assembly

The specifications are subject to alteration for improvement without notice.

O.S. GENUINE PARTS & ACCESSORIES

■ O.S.GLOW PLUG TYPE F
(71615009)



■ BOOSTER CABLE SET
(72200110)



■ BOOSTER TERMINAL KIT
(72200130)



■ PROPELLER LOCKNUT SET
(45810200 For Spinner)



■ Needle Valve Extension
Cable Set
(72200080)



■ PROPELLER LOCKNUT SET
FOR TRUTURN SPINNER
1/4"-M5 (45810300)



■ FLEXIBLE EXHAUST PIPES



Code.No.	Type	Length (mm)
72108100	1111A	120
72108110	1111B	240
72108120	1111C	170
72108130	1111D	330

■ EX EXHAUST HEADER PIPES
(72109500) (72109600)



Inside

Outside

■ NON-BUBBLE WEIGHT
(71531000)



■ SUPER FILTER (L)
(72403050)



■ LONG SOCKET WRENCH
WITH PLUG GRIP
(71521000)

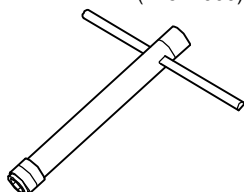

■ VALVE ADJUSTING
TOOL LIT (72200060)



■ LOCK WASHER
M3 (55500002)
(10sets)



■ BLIND NUT
M3 (79870030)
(10pcs./sets)



■ CAP SCREW SETS
(10pcs./sets)
M2. 6x8 (79871025)
M2. 6x18 (79871055)
M3. 5x20 (79871100)

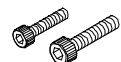

The specifications are subject to alteration for improvement without notice.

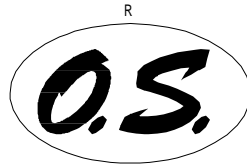

O.S. ENGINES MFG.CO.,LTD.

6-15 3-Chome Imagawa Higashisumiyoshi-ku
Osaka 546-0003, Japan TEL. (06) 6702-0225

FAX. (06) 6704-2722

URL : <http://www.os-engines.co.jp>

© Copyright 2003 by O.S.Engines Mfg. Co., Ltd. All rights reserved. Printed in Japan.

60091400 090304