

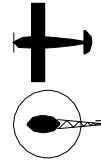

INSTRUCTION MANUAL
FOR AIRPLANE AND
HELICOPTER



XP652

6-CHANNEL COMPUTER RADIO

INTRODUCTION TO THE XP652 RADIO SYSTEM

Thank you for purchasing the JR XP652 6-Channel Radio System. This unit has been designed to provide the modeler with a high quality, user friendly radio system that can be depended upon for years to come.

It is important that you carefully read this manual before attempting to operate your XP652 System. Please pay particular attention to Page 13, Chapter 4 Charging Your XP652 Radio System Prior to Installing.

AMA INFORMATION

We strongly encourage all prospective and current R/C aircraft pilots join the Academy of Model Aeronautics. The AMA is a non-profit organization which provides services to model aircraft pilots. As an AMA member you will receive a monthly magazine entitled MODEL AVIATION, as well as a liability insurance plan to cover against possible accident or injury. All AMA charter aircraft clubs require

individuals to hold a current AMA sporting license prior to operation of their models. For further information you can contact the AMA at:

*Academy of Model Aeronautics
5151 East Memorial Drive
Muncie, IN 47302
(317) 287-1256*

XP652 SWITCH FUNCTION DECAL SHEET

Included with the XP652 radio system is a switch/function decal sheet. These decals have been provided as a guide to specific switch positions, functions, and abbreviations used when operating the XP652.

The large decal at the bottom of the sheet gives abbreviations and definitions for all of the aircraft and helicopter functions. The functions decal will prove to be a helpful guide for making program changes to your XP652 both in the shop and at the flying field.

The four small decals help identify switch positions and use for helicopter and aircraft modes.

XP652 FUNCTION GUIDE

HELI TOP LEFT	FLIGHT MODE NORMAL ▲ STUNT ▼	THROTTLE HOLD NORMAL STUNT ▼ ▲	HELI TOP RIGHT
AIR TOP LEFT	GEAR OR MIX DOWN OFF ▲ UP ON ▼	MIX OR FLAP OFF ON ON DOWN UP ▼ ▲	AIR TOP RIGHT

Airplane REV Servo Reversing DR Dual Rates EXP Exponential SUBTRM Sub-Trim TRV ADJ Travel Adjustment MIX A/R Aileron/Rudder Mix MIX E/F Elevator/Flap Mixing MIX DF Differential OFFSET Fly/Reverber Offset MIX A Programmable Mix A MIX B Programmable Mix B MIX C Programmable Mix C OFFSET Trim Offset Memory	Helicopter REV Servo Reversing DR Dual Rates EXP Exponential SUBTRM Sub-Trim TRV ADJ Travel Adjustment HLD Throttle Hold PLN Pitch Low Normal P2N Pitch Med Normal	PNH Pitch High Normal PLS Pitch Low Stunt P2S PMS Pitch Med Stunt P1S PHS Pitch High Stunt P1H PHL Pitch Low Hold P2H Pitch Med Hold P4H Pitch High Hold TLN Throttle Low Norm. T2N Throttle Med. Norm. THN Throttle High Norm. T2S Throttle Low Stunt T2S Throttle Med. Stunt MKX Revv Mixing RNU Revv Mixing Up RVD Revv Mixing Down A Programmable Mix A/STT STT Stunt Trim COP COPM Sweptblade Mix Offset Trim Offset Memory
--	---	--

**Tx BACK
DECAL SHEET**

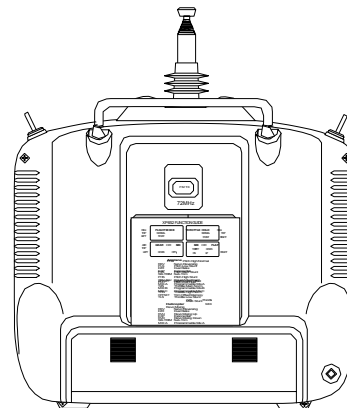

REAR DECAL POSITION
Airplane and Helicopter

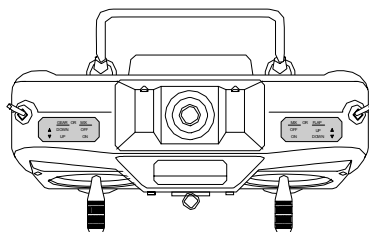

**AIRPLANE
DECAL POSITION**
Top View (Mode II)

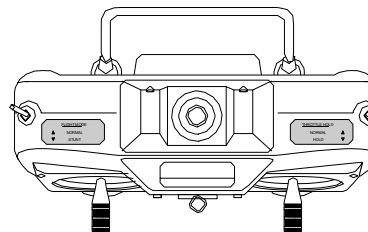

**HELICOPTER
DECAL POSITION**
Top View (Mode II)

In this manual you will find in-depth instructions that detail all the steps and procedures you should follow in order to program each of the XF652's features. For modelers who want to get into the air fast, we have provided Quick Start. Quick Start covers the basic

programming information necessary to get you airborne. Later, when you want to learn more about specific features of the XP652, turn to the appropriate page(s) in this manual for more detailed programming information.

Model Type Selection

1

Press the MODE and CHANNEL buttons simultaneously and hold while turning on the transmitter.

2

Press the MODE button until TYP appears on the screen.

3

If AC appears on the screen proceed directly to Step 4. If HE appears press the INCREASE or DECREASE button until AC appears, then press the MODE and CHANNEL buttons simultaneously to store the model type change.

4

Turn the transmitter off and then on again.

Servo Reversing

5

Press the MODE and CHANNEL buttons simultaneously until a beep is heard.

6

Press the MODE button until REV NORM appears on the screen.



Servo Reversing continued

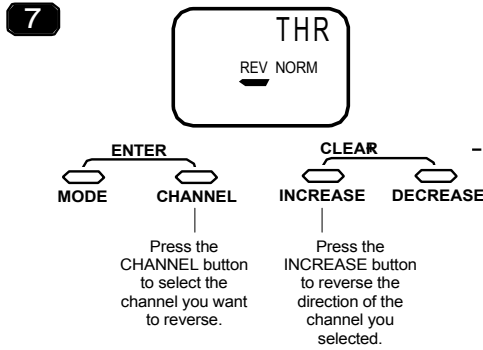

Travel Adjustment

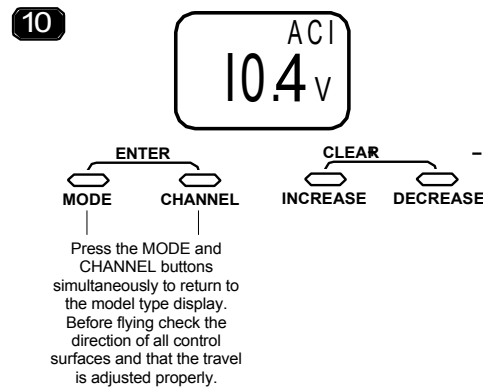
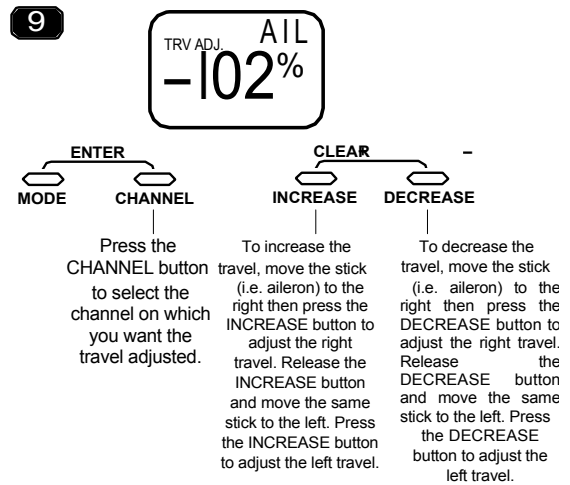
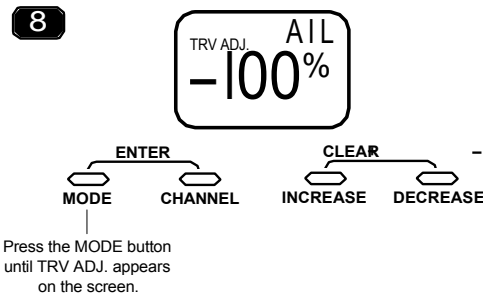

Model Type Selection

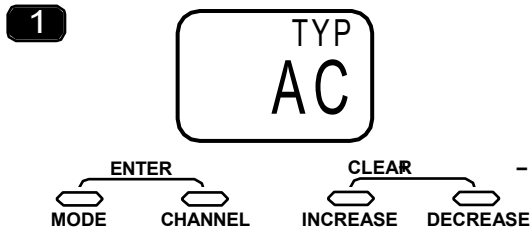

Press the MODE and CHANNEL buttons simultaneously and hold while turning on the transmitter.

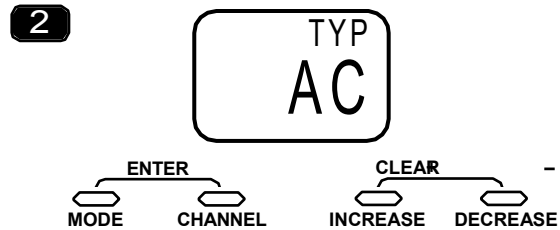

Press the MODE button until TYP appears on the screen.

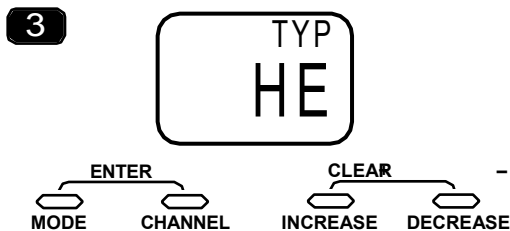

If HE appears on the screen proceed directly to Step 4. If AC appears press the INCREASE button until HE appears.

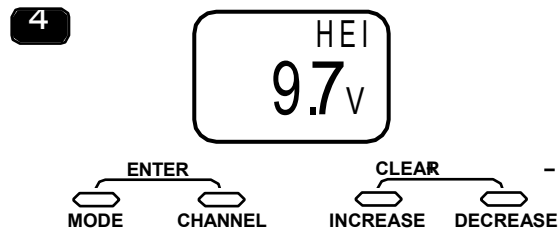

Press the MODE and CHANNEL buttons simultaneously until a beep is heard.

Servo Reversing

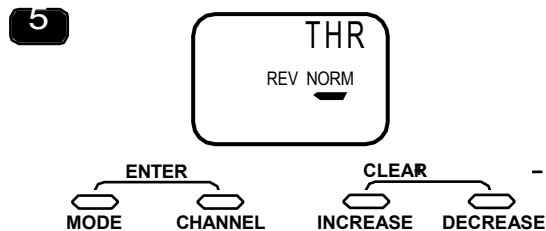

Press the MODE and CHANNEL buttons simultaneously until a beep is heard. REV NORM should appear on the screen.

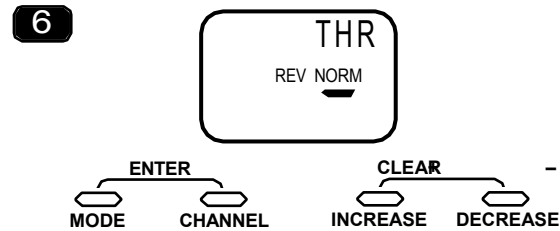

Press the MODE button until REV NORM appears on the screen.

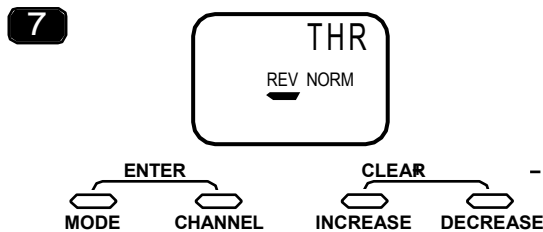

Press the CHANNEL button to select the channel you want to reverse.

Press the INCREASE button to reverse the direction of the channel you selected.



Travel Adjustment

8



Press the MODE button until TRV ADJ. appears on the screen.

9



Press the CHANNEL button to select the channel on which you want the travel adjusted.

To increase the travel, move the stick (i.e. aileron) to the right then press the INCREASE button to adjust the right travel. Release the INCREASE button and move the same stick to the left. Press the INCREASE button to adjust the left travel.

To decrease the travel, move the stick (i.e. aileron) to the right then press the DECREASE button to adjust the right travel. Release the DECREASE button and move the same stick to the left. Press the DECREASE button to adjust the left travel.

Pitch Curve

10

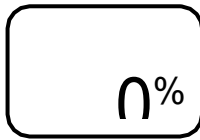

Press the MODE button until PLN appears on the screen.

11

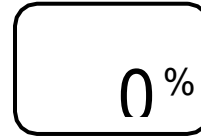

Press the CHANNEL button to select stick position (point location).

Press the INCREASE or DECREASE button to adjust the point value at the selected stick position.

STICK POSITION (POINT LOCATION)
L = Low
2 = Center
H = High

PRE-SET VALUES
L = 0%
2 = 50%
H = 100%

RECOMMENDED INITIAL PITCH SETTINGS
(Please refer to your helicopter kit instruction for pitch settings if available)
L = 0° Pitch
2 = 5° Pitch
H = 9° Pitch

Revolution Mixing

12

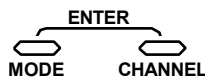
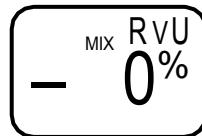

Press the MODE button until Mix RVU appears on the screen.

Revolution mixing value can be set for up or down. Press the CHANNEL button until U or D appears on the screen.

To change the direction of the mixing value press the INCREASE and DECREASE buttons simultaneously.

Press the INCREASE button to set the desired value of the up and down positions. **A good place to start is 35% up and 35% down.**



TABLE OF CONTENTS

I. INTRODUCTION		
1. Using This Manual	9	
2. Features	9	
2.1 Transmitter	9	
2.2 Receiver	9	
2.3 Servos	10	
3. Specifications	11	
3.1 System Specifications	11	
3.2 Transmitter Specifications	11	
3.3 Servo Specifications	11	
3.4 Receiver Specifications	12	
3.5 Charger Specifications	12	
3.6 Airborne Battery Pack	12	
4. Battery Charging	14	
4.1 Transmitter/Receiver	14	
4.2 Charger	14	
5. Trainer System	14	
II. AIRPLANE SECTION		
1. Transmitter Controls	15	
1.1 Control Identification and Location	15	
1.2 Receiver Channel Assignment/Transmitter Throttle ATL	15	
1.3 Transmitter Rear	16	
1.4 Control Stick Length Adjustment	17	
1.5 Direct Servo Control (DSC)	17	
1.6 Neck Strap Attachment	17	
2. Connections	18	
2.1 Installation Requirements	18	
2.2 Connections	18	
3. Key Input and Display	19	
4. Battery Alarm and Display	19	
5. Input Mode and Function	20	
5.1 Normal Display	20	
5.2 System Mode	20	
5.3 Function Mode	21	
6. Functions (System Mode)	22	
6.1 Model Type Selection	22	
6.2 Data Reset	23	
6.3 Dual Rate Switch Selection	24	
6.4 Wing Type Selection	25	
6.5 Model Selection	27	
6.6 Model Name Entry	28	
6.7 Modulation Select	29	
6.8 Fail-Safe/Hold	30	
6.9 Fail-Safe (Z-PCM)	30	
6.10 Fail-Safe (S-PCM)	32	
7. Functions (Function Mode)	34	
7.1 Servo Reversing	34	
7.2 Dual Rate	35	
7.3 Exponential	36	
7.4 Sub-Trim	37	
7.5 Travel Adjustment	38	
7.6 Aileron to Rudder Mixing	39	
7.7 Elevator to Flap Mixing	41	
7.8 Differential	43	
7.9 Flap to Elevator Offset Trim	44	
7.10 Programmable Mixing (A, B, C)	45	
7.11 Trim Offset	48	
8. Data Sheets	51	
III. HELICOPTER SECTION		
1. Transmitter Controls	52	
1.1 Control Identification and Location	52	
1.2 Receiver Channel Assignment/Transmitter Throttle ATL	52	
1.3 Transmitter Rear	53	
1.4 Control Stick Length Adjustment	54	
1.5 Direct Servo Control (DSC)	54	
1.6 Neck Strap Attachment	54	
2. Connections	55	
2.1 Installation Requirements	55	
2.2 Connections	55	
3. Key Input and Display	56	
4. Battery Alarm and Display	56	
5. Input Mode and Function	57	
5.1 Normal Display	57	
5.2 System Mode	57	
5.3 Function Mode	58	
6. Functions (System Mode)	59	
6.1 Model Type Selection	59	
6.2 Data Reset	60	
6.3 Dual Rate Switch Selection	61	
6.4 Gear/Gyro Switch Selection	62	
6.5 Model Selection	63	
6.6 Model Name Entry	64	
6.7 Modulation Select	65	
6.8 Fail-Safe/Hold	66	
6.9 Fail-Safe (Z-PCM)	66	
6.10 Fail-Safe (S-PCM)	68	
7. Functions (Function Mode)	70	
7.1 Servo Reversing	70	
7.2 Dual Rate	71	
7.3 Exponential	72	
7.4 Sub-Trim	73	
7.5 Travel Adjustment	74	
7.6 Throttle Hold	75	
7.7 Pitch Curve	76	
7.8 Throttle Curve	77	
7.9 Revolution Mixing	78	
7.10 Rudder Offset	79	
7.11 Programmable Mixing (A)	80	
7.12 Stunt Trim	83	
7.13 CCPM Swashplate mixing	84	
7.14 Trim Offset Memory	86	
8. Data Sheets	89	
8.1 Ergo .32/.46 Initial Setup	89	
8.2 Ergo .46 Initial Setup w/3D Pitch Curve	90	
8.3 Ergo .60 Initial Setup	91	
8.4 Blank Data Sheet	92	
IV. IMPORTANT INFORMATION		
1. General Notes	93	
2. Daily Flight Checks	93	
3. Warranty Coverage	94	
4. Repair Service Instructions	94	
5. Frequency Chart	95	

CHAPTER 1: USING THIS MANUAL • Introduction

1

USING THIS MANUAL

The XP652 is a full feature introductory computer radio that can be used for airplanes and/or helicopters. This manual is divided into two main sections — the first for airplanes and the second for helicopters. You need only refer to the section that pertains to the type of model you are programming — e.g., if you are programming your XF652 for helicopters, follow the instructions in the helicopter section.

Blank data sheets are included at the end of both sections. Once you have input all the necessary data into your transmitter for a particular model, we strongly recommend that you immediately write that information down on a copy of the data sheet provided. This is to insure that, in the rare case of a memory failure, you will not lose your data.

CHAPTER 2: FEATURES • Introduction

2.1

TRANSMITTER FEATURES

Airplane and Helicopter Mode

- Easy-to-read LCD screen
- Five model name entry
- Five model memory
- Dual rates on aileron and elevator
- Dual rates can be combined on one switch
- Exponential rate on aileron and elevator
- Trainer system compatible with most other JR radios
- Flush mounted programming buttons
- Computer designed ergonomically styled case
- Adjustable stick length
- Throttle trim only affects idle position
- Two speed scrolling—Press and hold the appropriate button to scroll quickly or press and release to scroll in steps.
- FM/PCM selectable
- Fail-safe/fail-safe memory (PCM only)
- Trim offset memory

Airplane Mode

- Aileron to rudder mixing
- Elevator to flap mixing
- Flap to elevator mixing
- Flaperons mixing
- Delta wing mixing
- Aileron differential
- V-tail mixing
- Three programmable mixes
- Mixing differential

Helicopter Mode

- Two 3-point throttle curves
- Two 3-point pitch curves (three when throttle hold is activated)
- Flight mode switch can combine throttle curve, pitch curve, dual rates, and gyro sensitivity
- Throttle hold with rudder offset
- Revolution mixing up and down
- Programmable mixing
- Stunt Trim
- Optional CCPM Swashplate mixing

2.2

RECEIVER FEATURES

R600 Receiver

- The R600's extremely compact size allows it to fit easily in limited-space airplanes and helicopters. It's ultra-low weight keeps overall model weight down.
- An independent laboratory ranked the R600 receiver with JR's patented ABC&W circuitry as one of the best receivers ever tested in terms of 3IM, 2IM, adjacent channel rejection, signal-to-noise ratio, and on-channel capture point.
- A special "unwanted interference limiter" ignores signals outside of the R600's band width when

the receiver is on and the transmitter is off. The limiter also prevents servos from random glitching when other transmitters are operating in close proximity.

- The electrical circuitry in the R600 is state-of-the-art surface mount technology (SMT). These SMT components draw less current, thus increasing flying time. Flush mounting of these components also reduces the risk of vibration wear and damage.
- The R600 is compatible with all JR FM-transmitting radios.

2.3 SERVO FEATURES

517 Servo

- A .03ms deadband amplifier insures accurate neutral centering.
- Low current drain.
- Ball bearing supported ouput shaft
- An indirect drive feedback potentiometer gives additional protection from vibration.
- Redesigned features include SMT circuitry.
- 3-pole ferrite cored motor.

2.4 SERVO LAYOUT

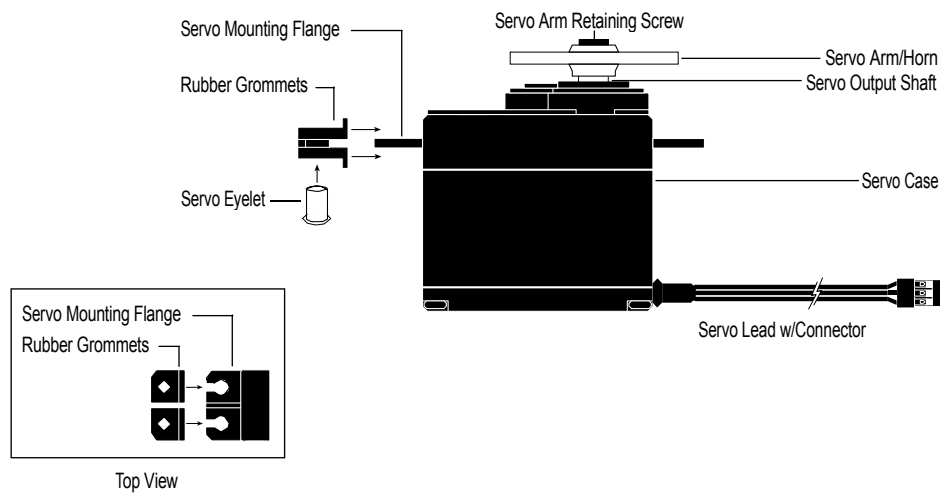

CHAPTER 3: SPECIFICATIONS • Introduction

3.1 SYSTEM SPECIFICATIONS

TYPE	AIRPLANE	HELI COPTER
SYSTEM NAME	XP652A	XP652H
TRANSMITTER BODY	NET-E136U	NET-E136U
RECEIVER	R600	R600
CHARGER	NEC-221	NEC-222
AIRBORNE BATTERY	4N-600	4N-1000
SERVOS	NES-517BBX4	NES-517BBX5
ACCESSORIES	Mini Switch 12" Aileron Extension Servo Accessories Instruction Manual	Mini Switch 12" Aileron Extension Servo Accessories Instruction Manual

3.2 TRANSMITTER SPECIFICATIONS

TYPE	AIRPLANE	HELI COPTER
MODEL NUMBER	NET-E136U	NET-E136U
ENCODER	6 Channel Computer System	6 Channel Computer System
RF	50/53/72 MHz	50/53/72MHz
MODULATION	PPM (FM), PCM (S,Z)	PPM (FM), PCM (S,Z)
OUTPUT POWER	Approximately 1 Watt	Approximately 1 Watt
CURRENT DRAIN	200mA	200mA
POWER SOURCE	1.2Vx8 Nicad (9.6V) 600mah	1.2Vx8 Nicad (9.6V) 600mah
OUTPUT PULSE	1000-2000 (1500 Neutral)	1000-2000 (1500 Neutral)

3.3 SERVO SPECIFICATIONS

TYPE	517BB
TORQUE (oz./in.)	40.3
SPEED	.25
WEIGHT	1.47
SIZE (in.) (W x L x H)	0.73 x 1.52 x 1.32
BB	YES
MOTOR	3-Pole Ferite

3.4 RECEIVER SPECIFICATIONS

TYPE	R600 FM
MODEL NUMBER	NER-600
TYPE	6-Channel/FM-ABC & W/Circuitry
FREQUENCY	50/53/72MHz
SENSITIVITY (Microseconds)	5µs Minimum
SELECTIVITY	8KHz/50dB
WEIGHT (oz.)	1 oz.
SIZE (in.) (W x L x H)	1.43 x 2.06 x .55
RECEIVER ANTENNA	39" For All Aircraft Frequencies

3.5 CHARGER SPECIFICATIONS

TYPE	AIRPLANE	HELICOPTER
MODEL NUMBER	NEC-211	NEC-222
INPUT VOLTAGE	AC 100-120V	AC 100-120V
OUTPUT CURRENT		
CHARGING TIME	50mAh Tx/50mAh Rx	50mAh Tx/150mAhRx
	15 Hours	15 Hours

3.6 AIRBORNE BATTERY PACK

TYPE	AIRPLANE	HELICOPTER
MODEL NUMBER	4N-600	4N-1000
VOLTAGE	4.8V	4.8V
SIZE (in.) (W x L x H)	2.24 x 0.59 x 2.05	2.60 x 0.63 x 1.70
WEIGHT (oz.)	3.3	4.9

CHAPTER 4: BATTERY CHARGING • Introduction

4.1 TRANSMITTER/RECEIVER

It is imperative that you fully charge both the transmitter and the receiver battery packs prior to each day of flying. For the initial charge, leave the charger and batteries hooked up for 20-24 hours in order to fully charge both battery packs to peak capacity. For subsequent charges, leave the charger and batteries hooked up overnight (approximately 16 hours).

The charger supplied with this system is designed to recharge your transmitter battery at a rate of 50mA. The receiver battery pack will charge at 50mA for the 600mAh airplane battery pack and at 150mA for the 1000mAh helicopter battery pack.

Transmitter Only

The center pin on all JR remote control systems is **negative**. Therefore, the center pin on all JR chargers is negative, not positive. This is different from any other manufacturers' chargers and radio systems. Beware of improper connections based on "color code" wire leads as they DO NOT APPLY in this instance. You must make certain that the center pin of your JR transmitter is always connected to the negative voltage for correct polarity hookup.

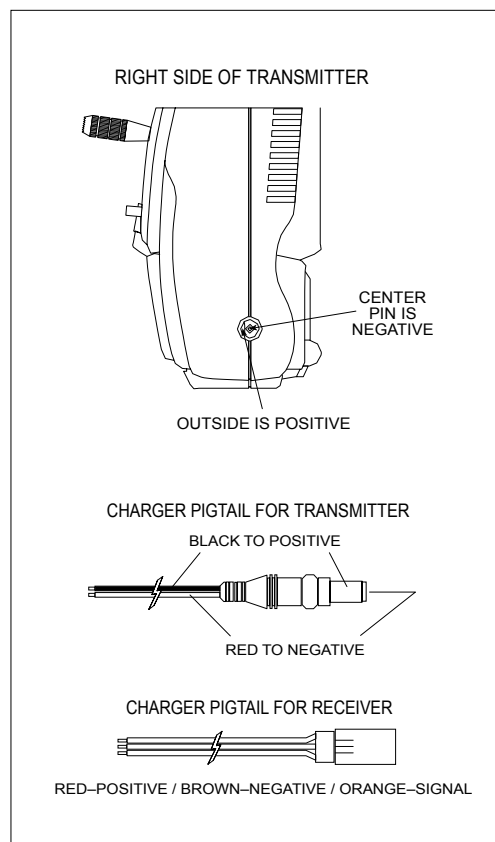

4.2 CHARGER

The pilot lamps should always be on during the charging operation. If they are not, check to make sure you have turned off both the transmitter and receiver.

Do not use the charger for equipment other than JR. The charging plug polarity may not be the same and equipment damage may result.

Do not use other manufacturers' after-market accessories that plug into the transmitter's charging jack. If you do, any damage that results will not be covered by warranty. If you are unsure of compatibilities with your radio, seek expert advice before doing anything to avoid possible damage. During the charging operation, the charger's temperature is slightly elevated. This is normal.

CHAPTER 5: TRAINER SYSTEM • Introduction

5

TRAINER SYSTEM

The XP652 features a built-in trainer system. The transmitter can be used as either a master (trainer) or as a slave (trainee). The XP652 is compatible

with all other current JR radios that have built-in trainer systems. An optional trainer cord is needed (JRPA130).

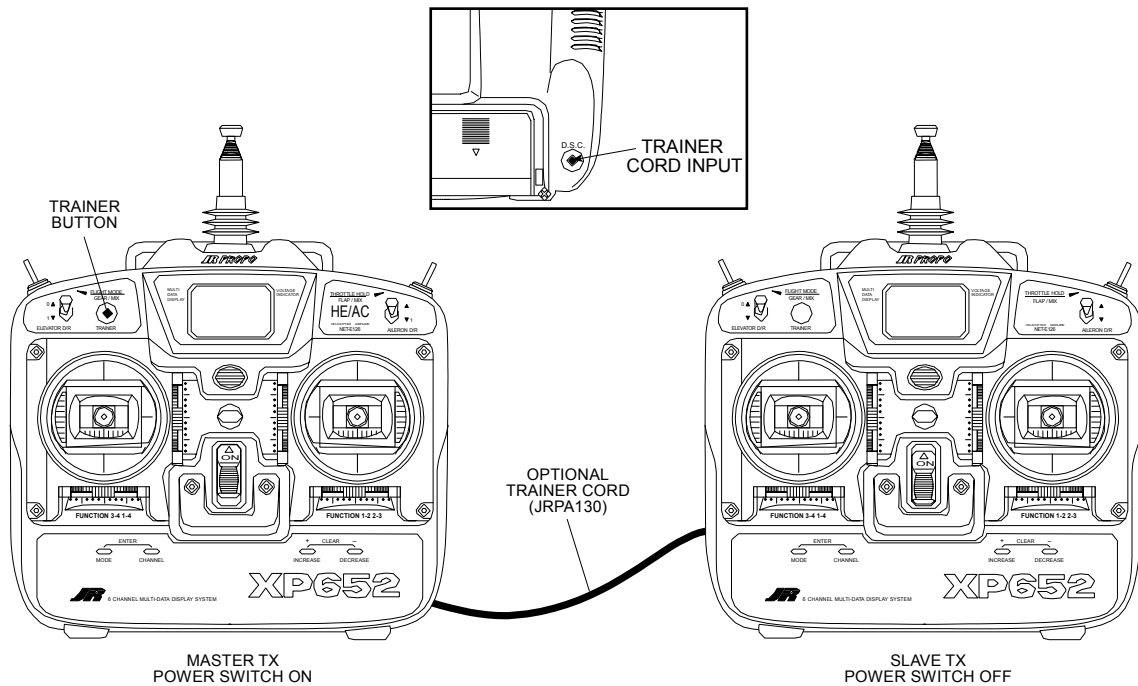

Operating the Trainer System

1. Match the servo reversing and trims of both radios.
2. Plug the optional trainer cord into both transmitters.
3. Turn on the master transmitter. (**Note:** The slave radio must be left off.)
4. Test all the control functions on your aircraft with the master radio.
5. Push the trainer button on the master transmitter and check all the control functions with the slave radio.

CHAPTER 1: TRANSMITTER CONTROLS • Airplane

1.1 CONTROL IDENTIFICATION AND LOCATION • Mode II

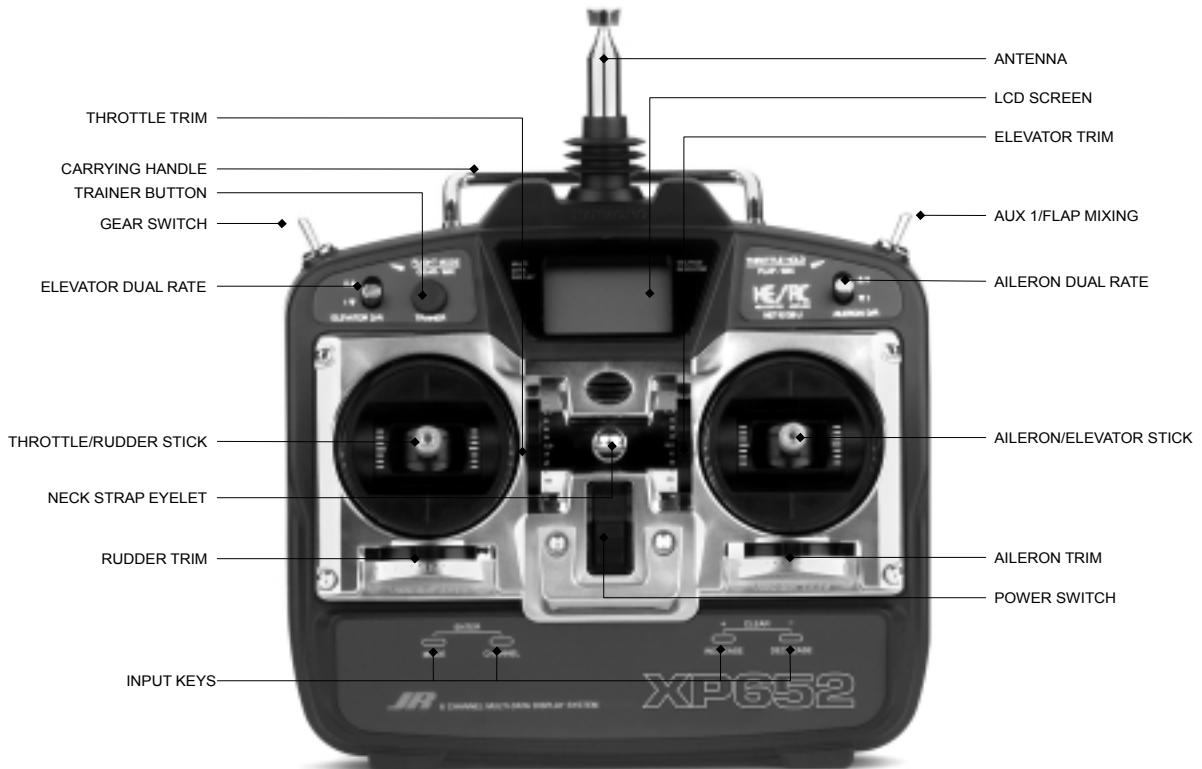

1.2 RECEIVER CHANNEL ASSIGNMENT/TRANSMITTER THROTTLE ALT

- | | | |
|----|-------|----------------------------|
| 1. | THRO | Throttle Channel |
| 2. | AILE | Aileron Channel |
| 3. | ELEV | Elevator Channel |
| 4. | RUDD | Rudder Channel |
| 5. | GEAR | Gear Channel |
| 6. | AUX 1 | Auxiliary 1 Channel (Flap) |

Transmitter Throttle ALT

The throttle ALT function makes the throttle stick trim active only when the throttle stick is less than half throttle. This gives easy, accurate idle adjustments without affecting the high throttle position.



1.3 TRANSMITTER REAR

Note: Your transmitter has a 5-year lithium battery to protect your pre-programmed data against main transmitter battery failure. If your system reads 0.0 volts, or has an unfamiliar display (service mode) or

your data resets to the factory defaults, return your transmitter to Horizon Service Center (see page 91) for lithium battery replacement.

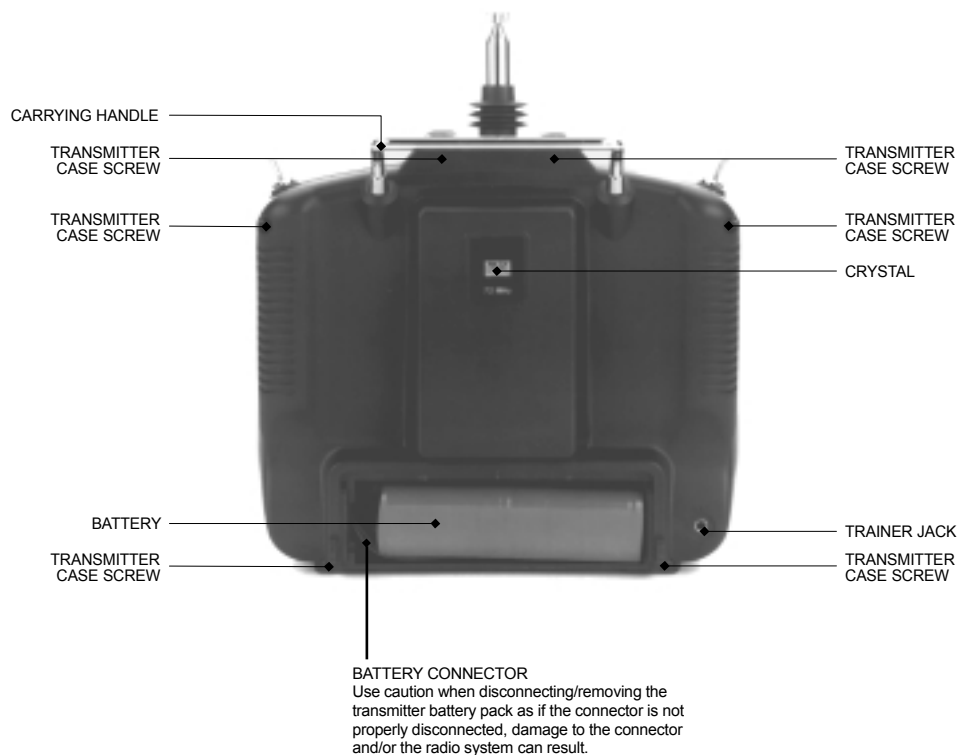

1.4 CONTROL STICK LENGTH ADJUSTMENT

To adjust the control stick length, use a 2mm Allen wrench to unlock the set screw located inside the end of the control stick. Turn the set screw counterclockwise to loosen it, then turn the knurled portion of the stick to adjust the length. Counterclockwise will lengthen the stick and clockwise will shorten it. After the control stick(s) has been adjusted to suit your flying style, tighten the set screw.

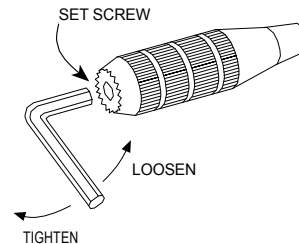

1.5 DIRECT SERVO CONTROL (DSC)

For proper DSC hook-up and operation:

1. Leave the transmitter power switch off. The transmitter will not transmit any radio frequency (RF) in this position.
2. Plug the optional DSC cord (JRPA132) into the DSC port in the rear of the transmitter.
3. The encoder section of the transmitter will now be operational and the LCD display will be lit.
4. Plug the other end of the DSC cord into the receiver charge receptacle. Turn on the switch harness.

Note: When installing the optional charging jack (JRPA024) be sure to hook the charging jack receptacle securely into the switch harness charge cord.

Why you should use the DSC function:

1. The DSC enables you to check the control surfaces of your airplane without drawing the fully operational 200mAh from your transmitter battery pack. Instead, you will only draw 70mAh when using the DSC function.

Note: You will need to purchase (separately) both the DSC cord (JRPA132) and the JR Deluxe Switch Harness (JRPA001) to make use of the XP652 DSC function.

2. The DSC function allows you to make final adjustments to your airplane or helicopter without transmitting any radio signals. Therefore, if another pilot is flying on your frequency, you can still adjust your aircraft and not interfere with the other aircraft.

Note: Under no circumstances should you attempt to fly your aircraft with the DSC cord plugged in! This feature is for bench checking your aircraft only.

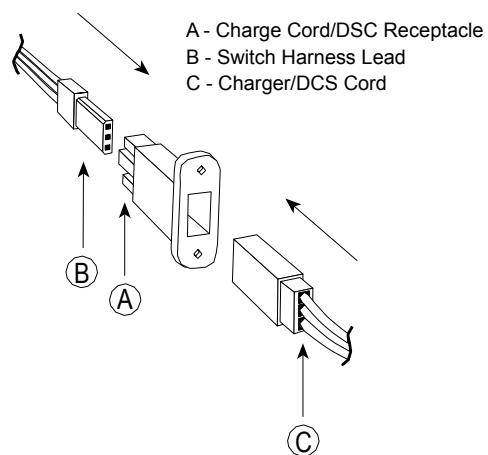

1.6 NECK STRAP ATTACHMENT

There is an eye hook on the front of the transmitter for attaching an optional neck strap (JRPA023). The eye hook is precisely positioned (see Section 1.1)

so that the transmitter will be perfectly balanced when a neck strap is used.



CHAPTER 2: CONNECTIONS • Airplane

2.1 INSTALLATION REQUIREMENTS

It is important to correctly install the radio system in your model. Please read and carefully follow the suggestions listed below.

1. For added protection, wrap the Rx and the Rx Nicad in foam rubber that is at least 1/4" thick.
2. Run the Rx antenna through the fuselage and make sure it is fully extended. Never cut or bundle your Rx antenna — this will decrease range and performance.
3. Rubber servo grommets are included with your radio system and should be installed in the servo flanges. The servos should then be mounted on either hardwood rails or a plywood tray with the mounting screws provided. **Do not overtighten the mounting screws.** The flange of the brass eyelets should face down (toward the wood).
4. All servos must be able to move freely over the full range of their travel. Make sure the linkages do not

impede servo travel. A stalled servo will drain the battery pack within a few minutes.

5. Before installing servo output arms, make sure the servo is in its neutral position.
6. In the case of gas-powered model aircraft, mount the receiver power switch on the side of the fuselage opposite the muffler to protect the switch from exhaust residue. With other types of models, mount the switch in the most convenient place. Make sure that the switch operates freely and is capable of traveling its full distance.
7. **With your model sitting on the ground and the transmitter antenna collapsed, check that your system works at a distance of 75 to 100 feet.**

If your system stops functioning at a distance that is shorter than listed above, please contact the Horizon Service Center for further information prior to flying your model.

2.2 CONNECTIONS

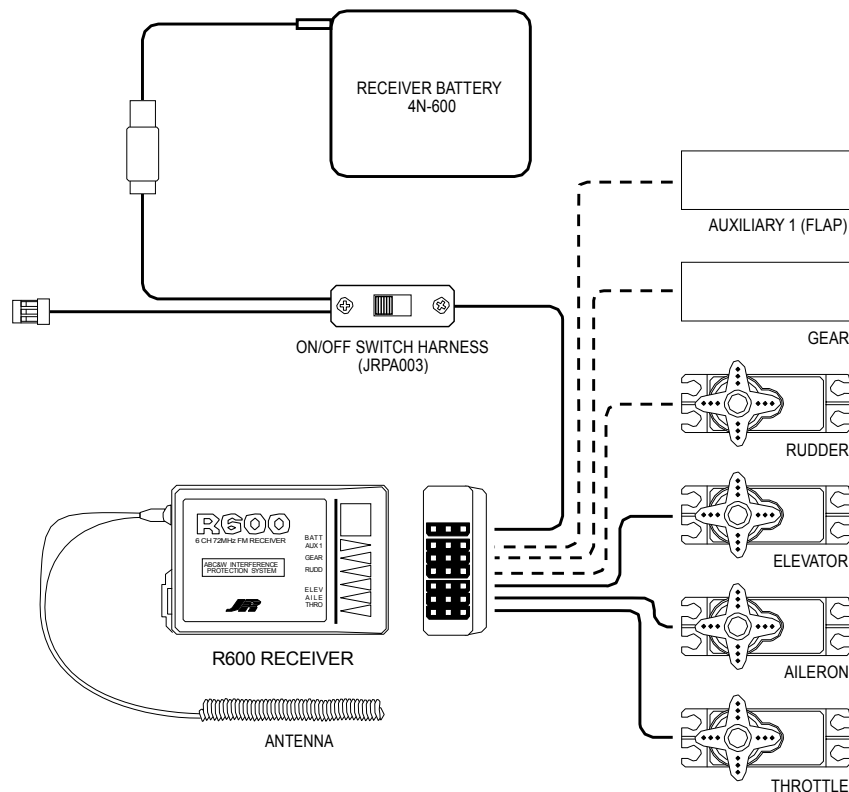

CHAPTER 3: KEY INPUT AND DISPLAY • Airplane

3

KEY INPUT AND DISPLAY

BUTTON	USE
MODE	Used to move up through the available functions
CHANNEL	Used to select the desired channel
INCREASE	Used to increase the value of the selected function
DECREASE	Used to decrease the value of the selected function

To enter the system mode press the MODE and CHANNEL buttons simultaneously and hold while turning on the transmitter.

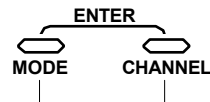

To enter the function mode press the MODE and CHANNEL buttons simultaneously while the transmitter is on.

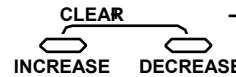

Press the INCREASE and DECREASE buttons simultaneously to clear the screen or return to factory preset.

CHAPTER 4: BATTERY ALARM AND DISPLAY • Airplane

4

BATTERY ALARM AND DISPLAY

When the transmitter battery drops below 9.0 volts, the display will start to flash BAT and an audible alarm will sound for 8 beeps. These warnings mean you should land your aircraft immediately.

Note: During the period that the battery alarm is flashing, the input buttons will not function. If you are currently in the function mode, the transmitter will exit automatically and return to the normal display (see Section 5.1).

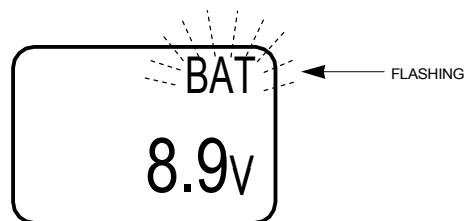

5.1 NORMAL DISPLAY

When the power switch is turned on the screen will read as shown here in the diagram. This screen is referred to as the normal display.

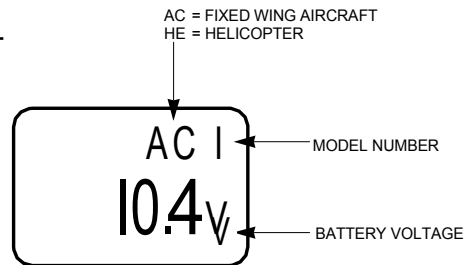

5.2 SYSTEM MODE

To enter the system mode, press the MODE and CHANNEL buttons simultaneously while you turn on the transmitter. You can now select any of 7 system mode functions shown here in the flow chart. To exit the system mode, press the MODE and CHANNEL buttons simultaneously or turn off the transmitter. Press the mode button to move through the system mode functions. Information for each function is located on the page number listed next to the function name.

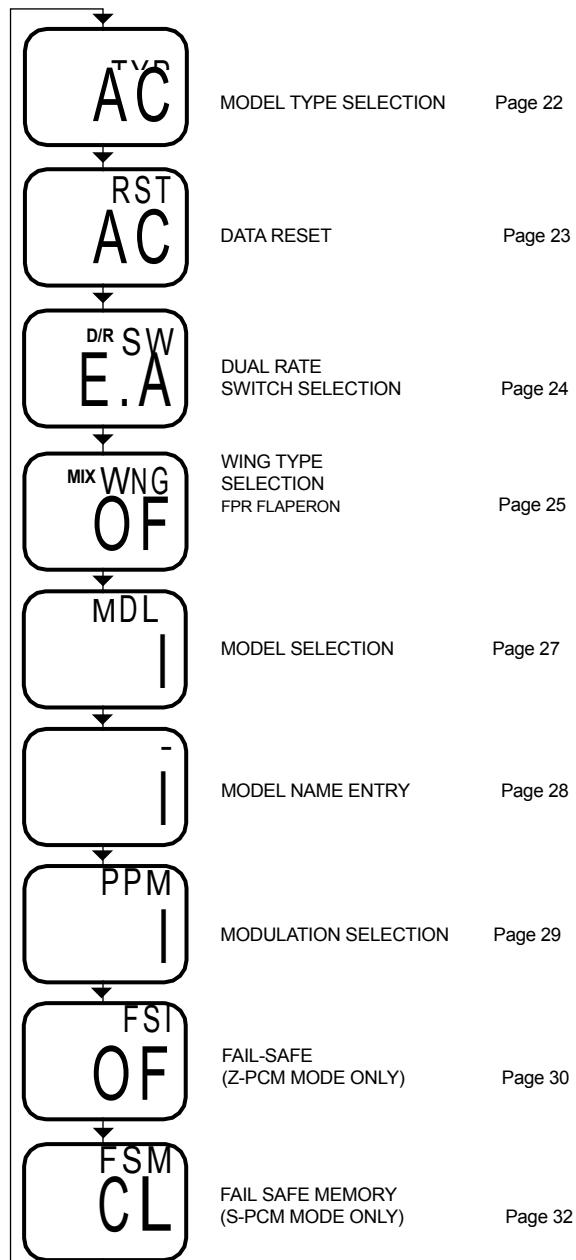

5.3 FUNCTION MODE

To enter the function mode, turn on the transmitter. Press the MODE and CHANNEL buttons simultaneously until a beep is heard. The display will change accordingly and show the last active function. Press the MODE button to scroll down through the functions one by one as shown in the flowchart below. Once the appropriate function is selected, use the CHANNEL button to select the appropriate channel. Use the INCREASE and DECREASE buttons to adjust the values displayed on the screen.

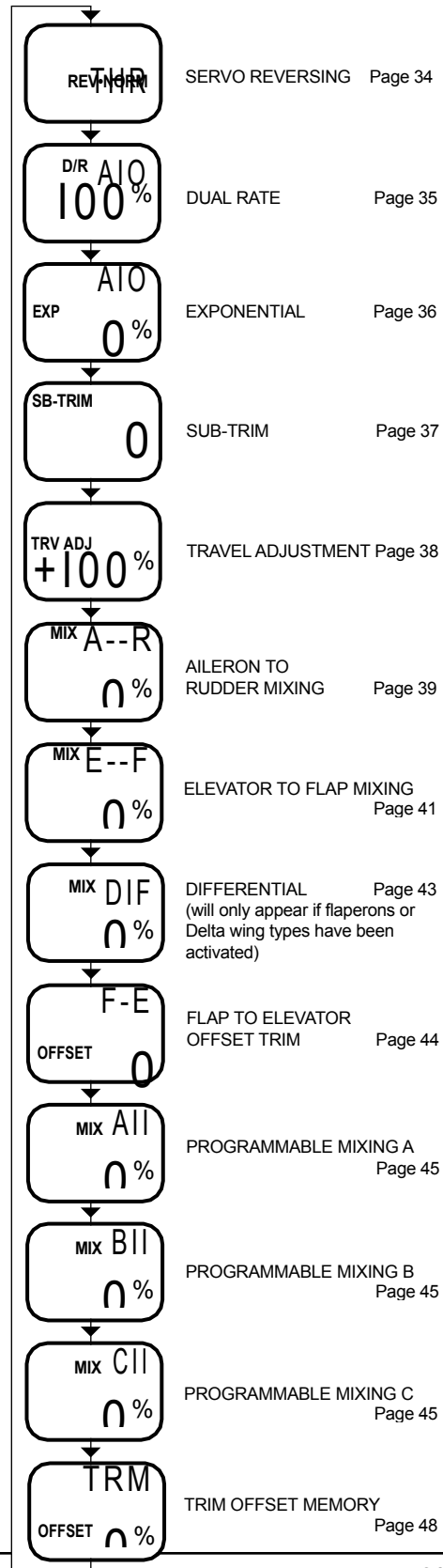

CHAPTER 6: FUNCTIONS • Airplane (System Mode)

6.1 MODEL TYPE SELECTION • System Mode

Two types of aircraft programming are available with the XP652, airplane (AC) and helicopter (HE). When you enter the model type selection function, the current model type will appear on the screen. (The current model type being the factory preset or the last model used.) When you press the increase or decrease button to change the model type, the new

model type indicated on the screen will flash. For example, if the current model type is AC and you change to HE, HE will flash on the screen. The flashing alerts you to the change of model type and will stop once you move to the next function or exit the system mode.

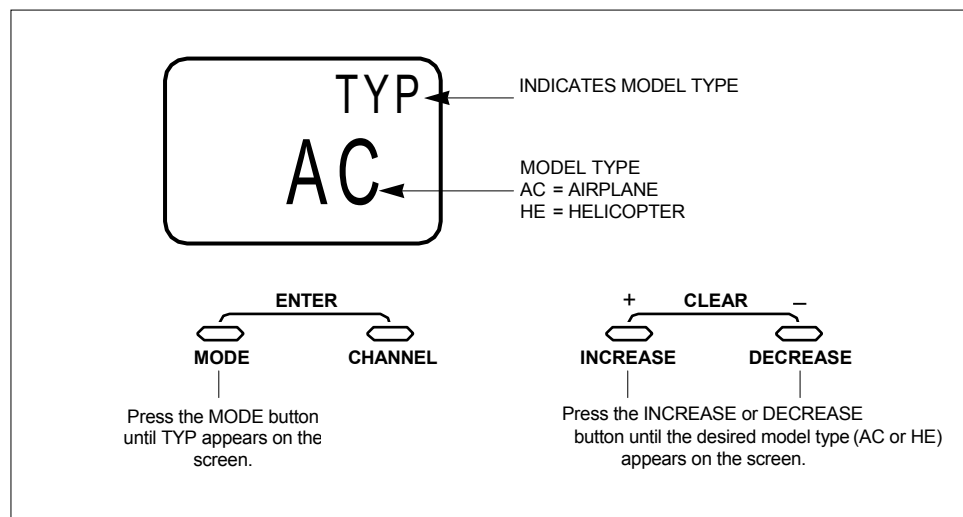

Accessing the Model Type Selection Function

1. Press the MODE and CHANNEL buttons simultaneously and hold.
2. Turn on the transmitter to enter the system mode.
3. Press the MODE button until TYP appears on the screen.
4. Press the INCREASE or DECREASE button until the desired model type appears on the screen (AC = airplane HE = helicopter).
5. Press the MODE button to access the data reset function.
6. To exit, press the MODE and CHANNEL buttons simultaneously.



6.2 DATA RESET • System Mode

The data reset function allows you to reset all the programming in the selected model (1-5) to the factory settings. Before using the data reset function it is important to enter the model

selection function and check that the current model number (1-5) indicated is the model that you want to reprogram to the factory settings. The model selection function is described in Section 6.5.

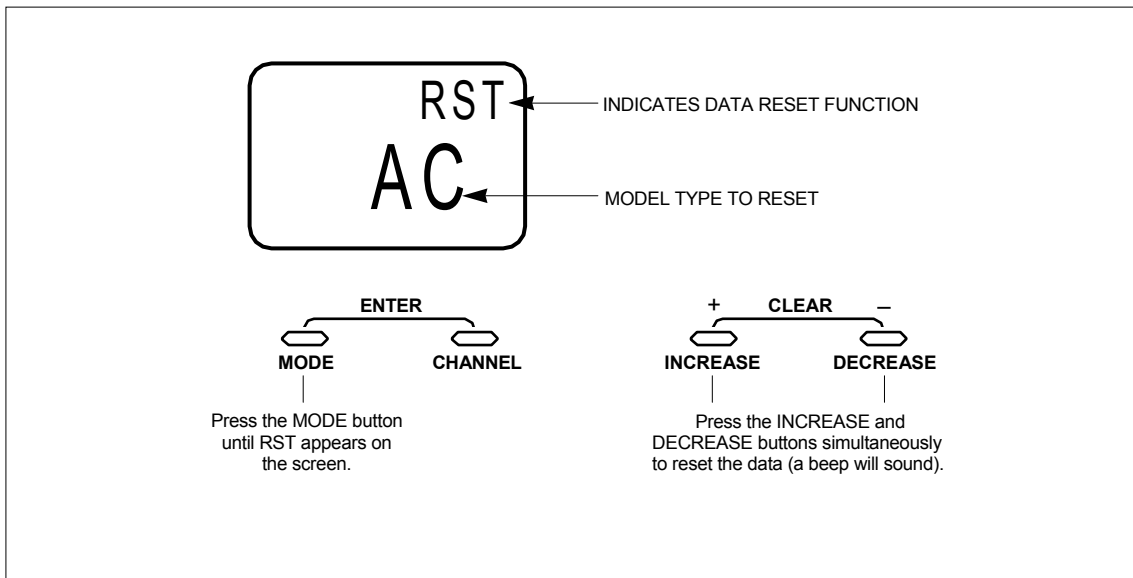

Accessing the Data Reset Function

1. Press the MODE and CHANNEL buttons simultaneously and hold.
2. Turn on the transmitter to enter the system mode.
3. Press the MODE button until RST appears on the screen.
4. Press the INCREASE and DECREASE buttons simultaneously to reset the data. (To confirm that the selected model's programming has been reset, a beep will sound and the AC or HE will momentarily disappear from the screen.)
5. Press the MODE button to access the dual rate switch selection function.
6. To exit, press the MODE and CHANNEL buttons simultaneously.



6.3 DUAL RATE SWITCH SELECTION • System Mode

The dual rate switch position is selectable and the elevator and aileron dual rates can be combined on one switch. This allows a single switch to be used when moving from high rates for wild maneuvers to low rates for mild maneuvers. Exponential Rate (EXP) is also available for both aileron and elevator and works in conjunction with the dual rate function to

provide mild control movements around neutral while allowing maximum servo travel. This reduces sensitivity in the middle portion of the stick control and still allows full travel at the end of the stick control. Refer to section 7.3 for exponential rate adjustment.

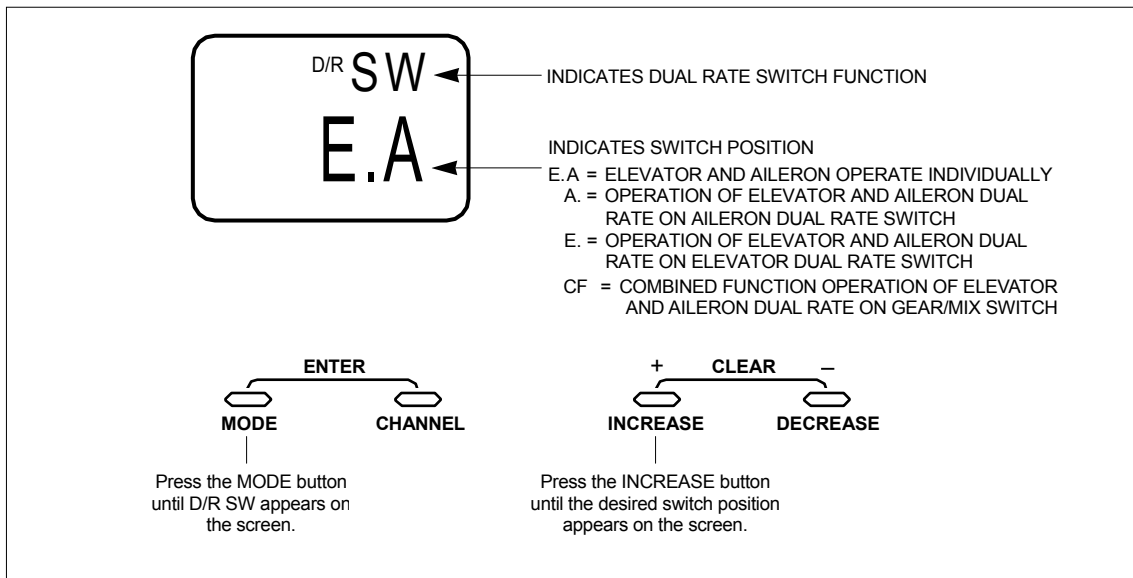

Accessing the Dual Rate Switch Selection Function

1. Press the MODE and CHANNEL buttons simultaneously and hold.
2. Turn on the transmitter to enter the system mode.
3. Press the MODE button until D/R SW appears on the screen.
4. Press the INCREASE button until the desired switch position appears on the screen.
5. Press the MODE button to access the wing type selection function.
6. To exit, press the MODE and CHANNEL buttons simultaneously.



6.4 WING TYPE SELECTION • System Mode

Flaperon, V-tail and Delta mixing are available for specialty aircraft that require those functions. The flaperon feature mixes flaps with ailerons so the ailerons can be drooped for takeoffs and landings while still functioning fully as ailerons. V-tail mixing combines rudder and elevator for V-tail operations. The Delta wing function allows the aileron to also act as the elevator, while retaining independent use of both functions. The Delta wing function allows the ailerons to also act as the elevator, while retaining independent use of both functions.

Flaperon Setup

When using flaperon mixing, two servos (one for each aileron) must be used. Connect the left aileron servo to channel #6 (Aux 1) and the right aileron servo to channel #2 (Aile) in the receiver. Individual functions (e.g., servo reversing, sub-trims, etc.) are still available for each of the channels. Use sub-trims for individual neutral adjustment. Adjust the aileron travel values by increasing or decreasing the aileron dual rate. Flap adjustments are made with flap left/right travel adjustment described in Section 7.5. Also see aileron

differential in Section 6.18.

V-Tail

V-Tail mixing requires two servos. Connect the left tail servo to channel #3 (Elev) and the right tail servo to channel #4 (Rudd) in the receiver. Individual functions (e.g., servo reversing, sub-trims, etc.) are available for each servo. Use sub-trims for individual neutral adjustments described in Section 7.4. V-Tail elevator travel is adjusted by elevator dual rates described in Section 7.2.

Delta Wing Mixing

Delta, or Elevon mixing as it is commonly known, is the final wing mixing selection in your XP652. This style of aircraft also employs two wing servos. However, in essence, there is not an elevator present. Instead, at an elevator stick input, the two wing servos function in conjunction with one another in the same direction to create an up/down movement of the aircraft. Also, when an aileron control is given, the two wing servos move in opposite directions to function as ailerons as well.

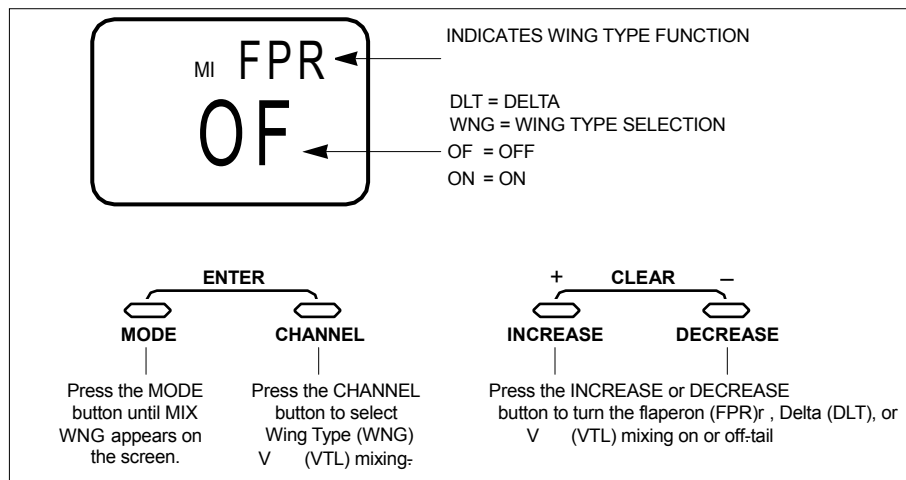

Accessing the Wing Type Selection Function

1. Press the MODE and CHANNEL buttons simultaneously and hold.
2. Turn on the transmitter to enter the system mode.
3. Press the MODE button until the MIX WNG appears on the screen.
4. Press the channel button to select either the wing type (WNG) or v-tail (VTL) mode.
5. Press the MODE button to access the Model Selection Function.
6. To exit, press the MODE and CHANNEL buttons simultaneously.



6.4 WING TYPE SELECTION • System Mode (continued)

To Activate Flaperon (FPR) Mixing (Wing Type Mode)

ENTER
MODE CHANNEL
Press the MODE and CHANNEL buttons simultaneously to activate and exit the system mode.

CLEAR -
INCREASE DECREASE
Press the INCREASE button to activate Flaperon mixing.

MIX
OF
OF = MIX OF
ON = MIX ON

To Activate Delta Wing (DLT) Mixing (Wing Type Mode)

ENTER
MODE CHANNEL
Press the MODE and CHANNEL buttons simultaneously to activate and exit the system mode.

CLEAR -
INCREASE DECREASE
Press the DECREASE button to activate Delta wing mixing.

MIX
OF

MIX
ON
DELTA WING
MIX ON

To Activate V-Tail (VTL) Mixing

ENTER
MODE CHANNEL
Press the MODE and CHANNEL buttons simultaneously to activate and exit the system mode.

Press the CHANNEL button once to access the V-tail mixing screen.

CLEAR -
INCREASE DECREASE
Next press either the + or - buttons once to activate V-tail mixing.

MIX
OF

MIX
OF

Note: It is also possible to activate both the flaperon (FPR) and V-tail functions (VTL) to work simultaneously.



6.5 MODEL SELECTION • System Mode

The XP652 has memory for five models. It can store the settings for five airplanes, five helicopters or three airplanes and two helicopters, ect.

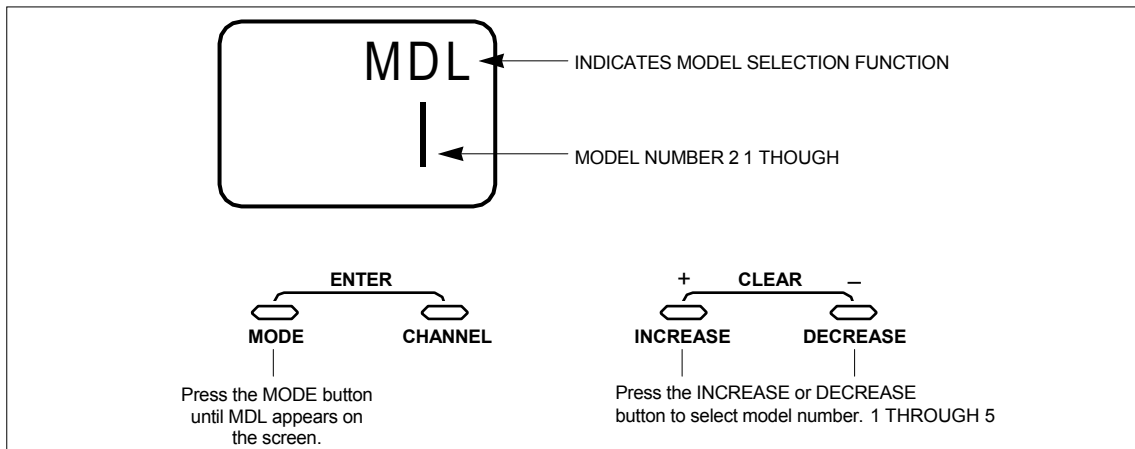

Accessing the Model Selection Function

1. Press the MODE and CHANNEL buttons simultaneously and hold.
2. Turn on the transmitter to enter the system mode.
3. Press the MODE button until MDL appears on the screen.
4. Press the INCREASE or DECREASE button to select model number 1 through 5.
5. Press the MODE button to access the model name entry function.
6. To exit, press the MODE and CHANNEL buttons simultaneously.



6.6 MODEL NAME ENTRY • System Mode

The XP652 allows a 3 digit name to be input for each of the five (5) models available. The current model will be displayed in the normal

display. This feature is useful to help identify different aircraft types, or model setups.

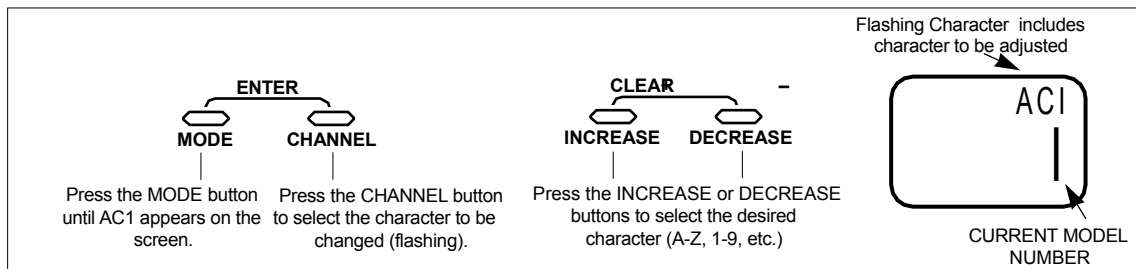

Accessing the Model Name Entry Function

1. Press the MODE and CHANNEL buttons simultaneously and hold.
2. Turn on the transmitter to enter the System Mode.
3. Press the MODE button until AC1 appears on the screen.
4. Press the INCREASE or DECREASE buttons to select the correct letter/number for the first character (flashing).
5. To adjust the remaining 2 characters, press the CHANNEL button until the desired character to be adjusted is flashing.
6. Press the MODE button to access the modulation select function.
7. To exit, press the MODE and CHANNEL buttons simultaneously.



6.7 MODULATION SELECT • System Mode

The modulation select function enables your XP652 to transmit to a variety of JR receivers that are already, or may soon be, in existence. You can select from either PPM (FM), Z-PCM or S-PCM,

depending on the central processing unit within your receiver to utilize existing receivers, or to upgrade your XP652 flight pack for future models. Your system comes factory preset in the FM or PPM (Pulse Position Modulation) position so that it is compatible with the included R600 FM receiver.

Please refer to the receiver compatibility chart below when selecting the modulation type for various JR receivers.

Note: Once the proper modulation has been selected for a specific model number, the modulation type will remain the same for that model number, even during model number/type changes. In other words, if you have one model on FM/PPM and one model on PCM, the system will automatically change modulation types once the correct modulation has been selected for that model.

Tx Modulation	Compatible Receivers	# of Channels & Brief Description	Tx Modulation	Compatible Receivers	# of Channels & Brief Description
PPM (FM)	NER-226	6 (micro)	Z-PCM	NER-236	6 (micro)
PPM (FM)	NER-228	8	Z-PCM	NER-627XZ or 627 "G" series	7
PPM (FM)	NER-327x	7	Z-PCM	NER-J329P	9
PPM (FM)	NER-527x	7 (micro)	Z-PCM	NER-910XZ	10
PPM (FM)	NER-529x	9 (micro)	S-PCM	NER-D940S	10
PPM (FM)	NER-549	9	S-PCM	NER-649S	9
PPM (FM)	NER-600	6 (micro)	S-PCM	NER-950S	10

Accessing the Modulation Select Function

1. Press the MODE and CHANNEL buttons simultaneously and hold.
2. Turn on the transmitter to enter the System Mode.
3. Press the MODE button until PPM appears on the screen.
4. Press either the INCREASE or DECREASE buttons to change the modulation to the desired setting FM (PPM), Z-PCM (ZPC) or S-PCM (SPC).
5. Press the MODE button to access the Model Type Function.
6. To exit, press the MODE and CHANNEL buttons simultaneously.

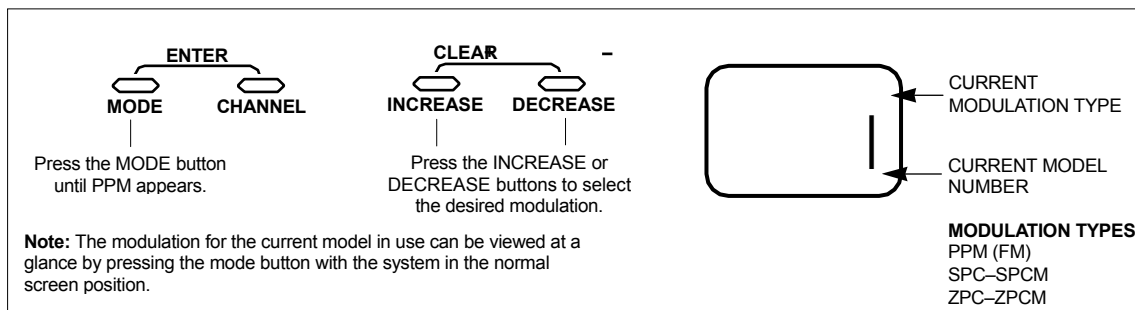

* **Note:** If either S-PCM or Z-PCM modulation is selected, pressing the MODE button will access the fail-safe/hold function.



6.8 FAIL-SAFE/HOLD (System Mode)

The Fail-Safe/Hold Function is available only when you use the XP652 transmitter in either of the PCM modulations – S-PCM or Z-PCM. This function is designed to help minimize damage to your airplane during a loss of signal to the receiver. The servos either assume the fail-safe presets or hold the last good signal position.

Note: In the PCM modulations, the Fail-Safe/Hold Function cannot be totally disabled so that the servos will react to interference in the same way as they do in a PPM system. This is only possible with the use of a PPM receiver and the transmitter in the PPM modulation.

Note: Since the actual screen appearance varies, depending on the modulation of your radio, refer to the appropriate modulation section which follows (Z-PCM, S-PCM).

As noted earlier, if you are in the PPM modulation, the Fail-Safe/Hold Function is not applicable. Therefore, the Fail-Safe/Hold Function will not appear on your LCD in the PPM mode.

Refer to the Modulation Selection Section for more information pertaining to the broadcast signal of your XP652 transmitter.

6.9 FAIL-SAFE/HOLD FUNCTION IN Z-PCM MODULATION (System Mode)

Hold (Z-PCM)

The Hold Function is automatically activated when the radio is turned ON and is in the Z-PCM modulation.

This function stops (or holds) the servos in the positions they were in just prior to the interference. Therefore, your airplane maintains the position held

immediately before the interference was experienced. When a clear signal is restored, the Hold Function releases, and control of the airplane returns to you.

If you would prefer your control surfaces to move to a chosen position during a loss of signal, please refer to the time delay/memory section below.

Accessing Fail-Safe/Hold (Z-PCM)

When the Fail-Safe Function is activated (i.e., when the signal is interrupted), the transmitter automatically moves each servo to a preset position. The position that each servo assumes is determined by you, as is the time length of interference that must occur before servo movement.

After the interference has ceased, control of the airplane returns immediately to you.

There are three time delays to choose from: 1/3 (0.3) second, 1/2 (0.5) second and 1.0 second. These time delays are the amount of time it takes, starting the

moment the interference occurs, until the servos assume their preset positions.

1. Press the MODE and CHANNEL button simultaneously and hold.
2. Turn on the transmitter to enter the System Mode.
3. Press the MODE button until FST appears on the screen.

Note: If Fail-Safe does not appear on your LCD, it is because you are transmitting in PPM. Fail-Safe is not applicable in the PPM mode. Refer to the Modulation Mode Selection Section for more information.



6.9

FAIL-SAFE/HOLD FUNCTION IN Z-PCM MODULATION

Setting Fail-Safe/Hold Time Delay/Memory In Z-PCM Modulation

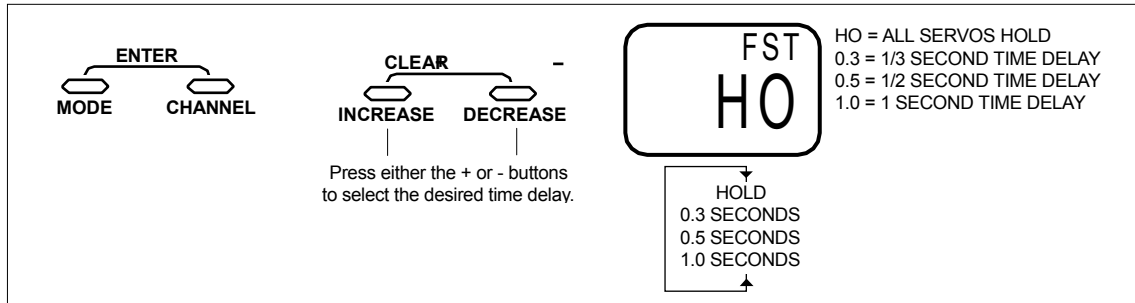

1. After accessing the Fail-Safe Function, it is now time to adjust the Fail-Safe Time Presets.
2. Select among the three time delays (0.3, 0.5, or 1.0

seconds) by pressing either the + or - buttons until the desired setting appears on the screen.

Setting Servo Position Presets

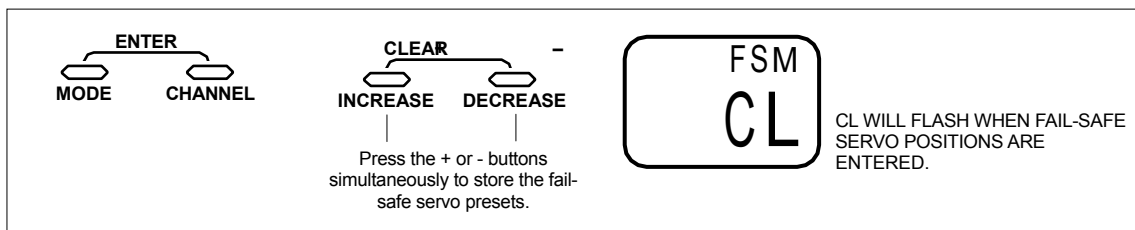

Note: If Hold position is selected (HO) this function/screen will not be present.

1. Press the MODE button until FSM appears on the screen.
2. Set all controls to the desired fail-safe position, then press the + and - buttons simultaneously. A high pitch beep sound will confirm that the preset positions have been entered.
3. Hold the transmitter sticks in the position that you want the servos to assume during signal loss conditions. You can determine fail-safe preset positions for the other channels by placing the control knobs and switches in the positions that you want them to assume during interference.
4. With the sticks, switches and control knobs in the fail-safe positions, press the + and - keys simultaneously. This will enter these locations as the fail-safe memory settings. A high pitched

beep will indicate that this setting has been stored.

5. To confirm that the input of data was successful, switch the transmitter OFF. The controls will move to the input locations. If not, repeat step 4 again.
6. To exit the Fail-Safe Function, press the MODE and CHANNEL buttons simultaneously.

Note: These preset positions remain stored in the transmitter's memory until both the transmitter battery pack and the lithium back-up battery have been removed (or until data reset has been performed). Therefore, you do not have to reset the fail-safe each time you fly. Should you want to re-adjust the fail-safe presets, access the Fail-Safe Function and adjust the presets as you have just done. The transmitter automatically recalls the settings for the last fail-safe adjustment.



6.10 FAIL-SAFE/HOLD FUNCTION IN S-PCM MODULATION (System Mode)

Hold Function (S-PCM)

The Hold Function is automatically activated when the radio is turned ON and in the S-PCM modulation.

This function stops (or holds) the servos in the positions they were in just prior to the interference.

Therefore, your aircraft maintains the position held immediately before the interference was experienced. When a clear signal is restored, the Hold Function releases, and control of the airplane returns to you.

Fail Safe/Hold Combination in S-PCM Modulation

The XP652 allows you to combine the hold and fail-safe presets for all six (6) channels on the receiver you can select fail-safe or hold independently for all channels on your aircraft. In other words, some channels will hold their last clear signal position, while others assume the preset position. Once the fail-safe has been activated by signal interruption (interference), the transmitter automatically moves the servos to a preset

position. The predetermined servo positions are set by you. In the S-PCM fail-safe, the time delay (the amount of time it takes, starting the moment the interference occurs, until the servos assume the preset positions) is fixed at .3, or 1/3, second.

After the interference has ceased, normal operation of the airplane returns to you immediately.



6.10 FAIL-SAFE • Hold Memory in S-PCM Modulation (continued)

Activating Servo Fail-Safe Pre-Sets by Channel (S-PCM)

1. Press the MODE and CHANNEL buttons simultaneously and hold.
2. Turn on the transmitter to enter the system mode.
3. Press the MODE button until FS1 appears on the screen. The #1 on the screen refers to the specific channel (1-6) to be adjusted.
4. Press the + or - button to activate (turn on) the preset position function for that channel.
5. Press the CHANNEL button to move to the next channel(s) to be adjusted (2-6). Repeat Step 4 for each channel to be activated.

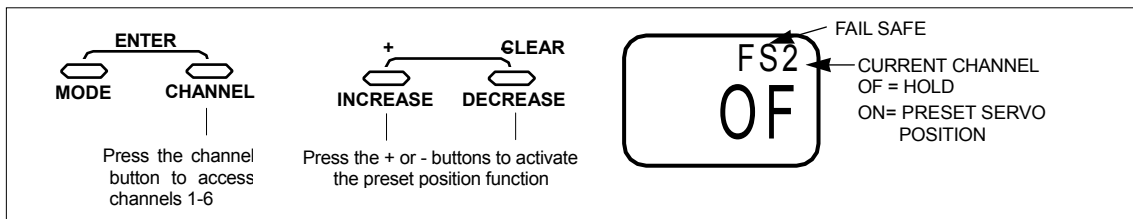

Note: If Hold Position (HO) is selected for all 6 channels, this Function/Screen will not be present.

Setting Servo Fail-Safe Presets in S-PCM Modulation

1. Press the MODE button until FSM appears on the screen.
 2. Set all controls to the desired Fail-Safe positions.
- Next press the + or - button simultaneously. A high pitch beep sound will confirm that the preset positions have been entered and accepted.

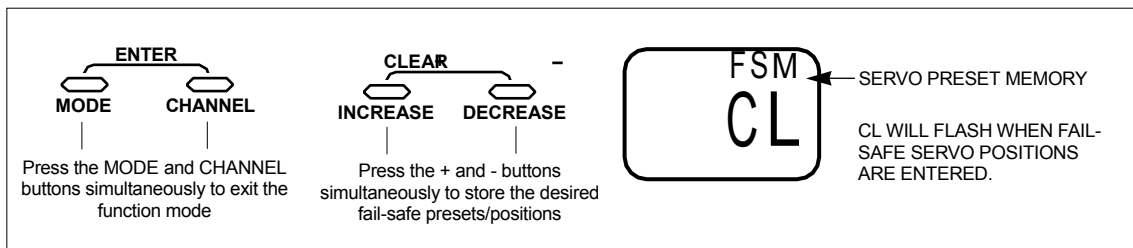

7.1 SERVO REVERSING • Function Mode

Servo reversing is a very convenient function used in the setup of a new aircraft. It is used to change the direction of servo rotation in relation to the

corresponding stick movement. Servo reversing is available for all 6 channels.

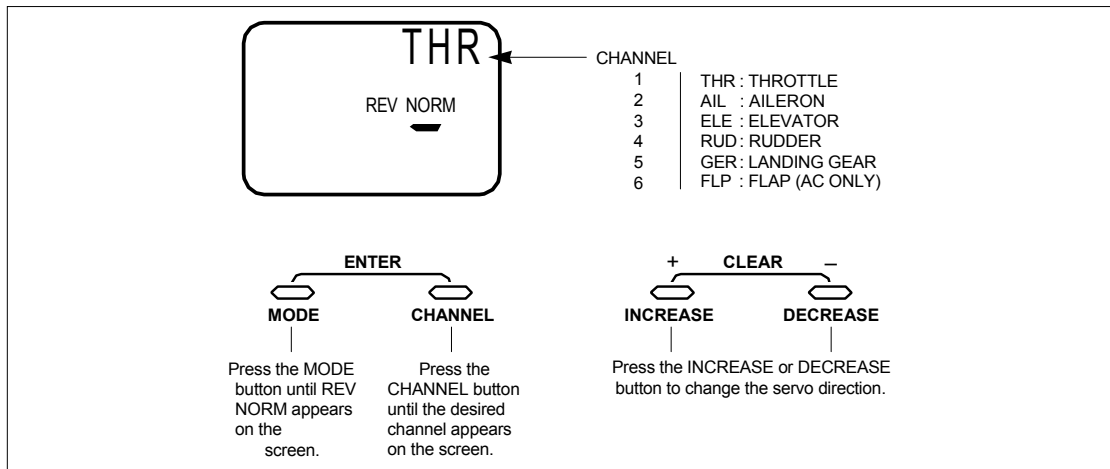

Accessing the Servo Reversing Function

1. Turn on the transmitter.
2. Press the MODE and CHANNEL buttons simultaneously to enter the function mode.
3. Press the MODE button until REV NORM appears on the screen.
4. Press the CHANNEL button until the desired channel appears on the screen.
5. Press the INCREASE or DECREASE button to change the servo direction.
6. Press the MODE button to access the Dual Rate function.
7. To exit, press the MODE and CHANNEL buttons simultaneously.



7.2 DUAL RATE • Function Mode

Dual rate is available for the aileron and elevator channels. The purpose of this function is to allow for in-flight selection of two preset servo travels for each of these channels. The amount of travel is adjustable from 0-125%. The factory settings for both switch positions (0 and 1) is 100%. Either position may be selected as the low or high rate by placing the switches in the desired position and adjusting the value for that position. Operation of these switches is described in Section 6.3.

Different types of maneuvers require varying amounts of control movements. Snap rolls require large control movements, while smooth maneuvers like long slow rolls are best performed with smaller control movements. Dual rates allow you to change the control movements in flight at the flip of a switch. This allows you to execute maneuvers requiring both radical control movements and small control movements during a single flight.

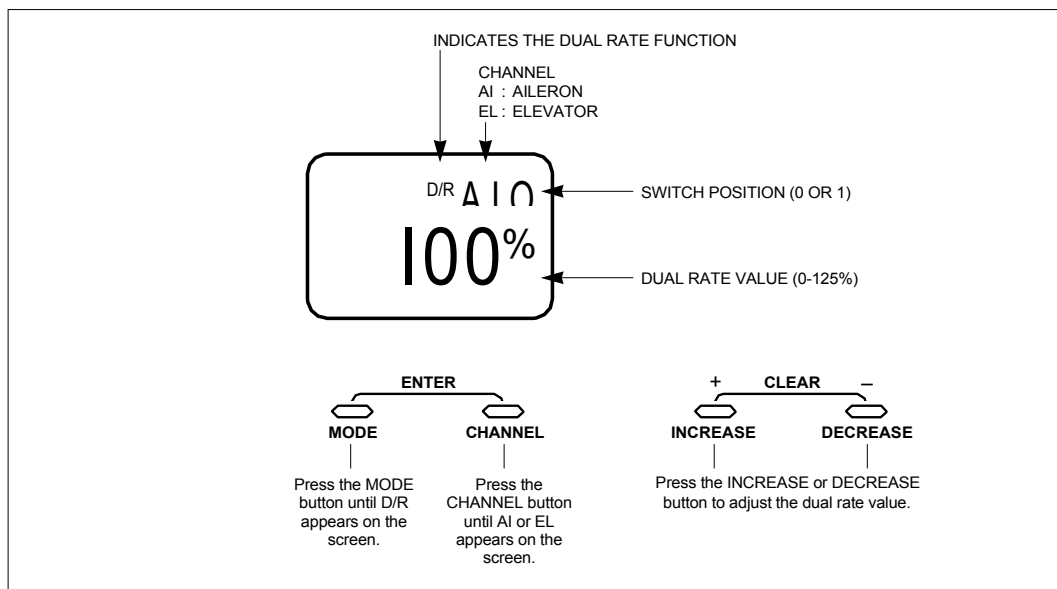

Accessing the Dual Rate Function

1. Turn on the transmitter.
2. Press the MODE and CHANNEL buttons simultaneously to enter the function mode.
3. Press the MODE button until D/R appears on the screen.
4. Press the CHANNEL button until the desired channel appears on the screen (AI = aileron or EL = elevator).
5. The number that appears directly to the right of the selected channel is the switch position. There are two switch positions, 0 and 1, for each of the channels. A 0 will appear when the selected dual rate switch is in the uppermost position and a 1 when the selected switch is in the lower position.
6. To change the switch selection you must enter the dual rate switch selection function in the system mode (see Section 6.3).
7. The number in the center of the screen indicates the current dual rate value for the selected switch position and channel. Press the INCREASE or DECREASE button to adjust the dual rate value (0-125%).
8. After adjusting the value for the 0 switch position, change to the 1 switch position and adjust the rates.
9. Press the CHANNEL button to select the other channel and adjust the dual rate value for both switch positions.
10. Press the MODE button to access the Exponential Rate feature.
11. To exit, press the MODE and CHANNEL buttons simultaneously.



7.3 EXPONENTIAL • Function Mode

Programmable exponential adjustments are offered on the aileron and elevator channels of your XP652 system. Exponential is a function that allows you to tailor the response rate of the controls as compared to the stick inputs. The purpose of exponential is to reduce the sensitivity in the middle portion of stick movement, while still allowing full travel at the end of the stick movement. In other words, the end result (travel) remains the same, although exponential changes the rate at which it achieves this travel.

The adjustable range of the Exponential Function is from 0–100%. Zero percent (0%) is linear stick control which means that the response rate is equal

throughout the stick control. One hundred percent (100%) is full exponential. The larger the exponential value, the less servo action, or sensitivity, you will notice around the neutral setting.

Note: The Exponential Function operates in conjunction with the Dual Rate Function. It is imperative to understand the Dual Rate Function prior to adjusting the exponential values.

Exponential may be selected independently for either the high or low rate (position 0 or 1), or both.

Note: The dual rate switch position is changed/accessed by setting the appropriate dual rate switch to the 0 or 1 positions.

ENTER

MODE CHANNEL

Press the MODE button until EXP appears on the left side of the screen

Press the CHANNEL button to select either aileron or elevator exponential

CLEAR

INCREASE DECREASE

Press the + and - buttons to increase/decrease the exponential value (0 - 100%)

A GOOD STARTING POINT FOR EXPONENTIAL VALUE IS APPROXIMATELY 20% – 30%.

Accessing the Exponential Function

1. Turn on the transmitter.
2. Press the MODE and CHANNEL buttons simultaneously to enter the Function Mode.
3. Press the MODE button until EXP appears at the left side of the screen.
4. Press the CHANNEL button until the desired channel appears on the screen (AI or EL).
5. Using the appropriate dual rate switch, select the correct position to be adjusted (0 or 1).
6. Press the + or - buttons to increase/decrease the exponential value.
7. Press the MODE button to access the sub-trim Function.
8. To exit, press the MODE and CHANNEL buttons simultaneously.



7.4 SUB-TRIM • Function Mode

Sub-trim is an electronic trim that is available for each of the 6 channels. Sub-trim is particularly useful as it allows the mechanical trim levers to be returned to their neutral positions by adjusting /changing the servo's neutral position electronically, without the need to mechanically adjust the specific control linkage. This allows the same mechanical trim lever settings between the four models you can control

with this radio system. Sub-trim can also allow additional trim travel when mechanical trims do not provide enough movement.

Note: It is recommended to use as little subtrim as possible for adjustment. If more than 20-30 points are required, it is suggested that a mechanical linkage adjustment be performed.

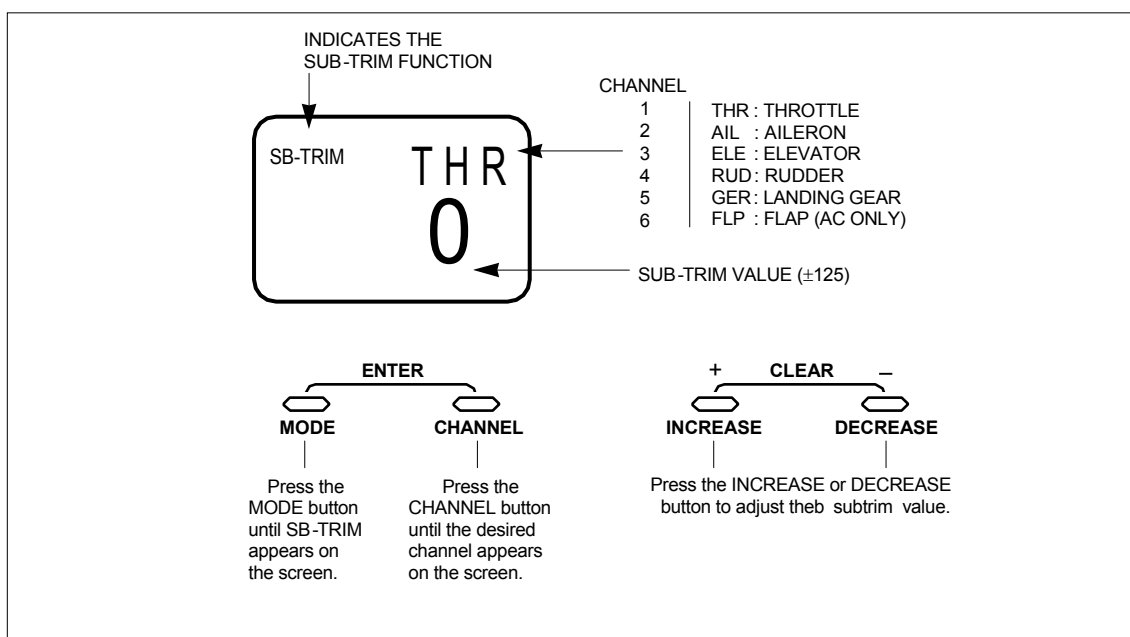

Accessing the Sub-Trim Function

1. Turn on the transmitter.
2. Press the MODE and CHANNEL buttons simultaneously to enter the function mode.
3. Press the MODE button until SB-Trim appears on the screen.
4. Press the CHANNEL button until the desired channel appears on the screen.
5. Press the INCREASE or DECREASE button to establish the desired amount of sub-trim.
6. Press the MODE button to access the travel adjustment function.
7. To exit, press the MODE and CHANNEL buttons simultaneously.



7.5 TRAVEL ADJUSTMENT • Function Mode

The amount of servo travel is adjustable for each direction for each of the 6 channels individually. The adjustment range is from 0% to 150%. Travel adjustment is factory set at 100% for all channels. The travel adjustment value displayed on the screen

depends on the position of the stick or switch (e.g., flap switch, gear switch). This function is useful either to maximize control surface travel, or to reduce travel to eliminate servo binding without the need for mechanical adjustment.

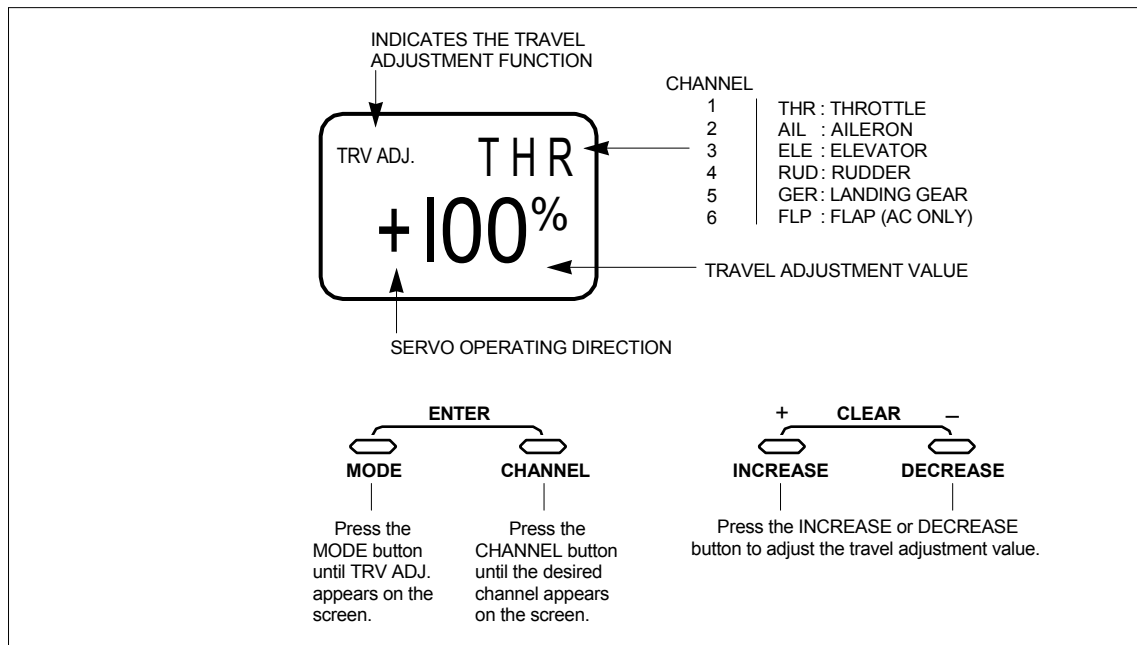

Accessing the Travel Adjustment Function

1. Turn on the transmitter.
2. Press the MODE and CHANNEL buttons simultaneously to enter the function mode.
3. Press the MODE button until TRV ADJ. appears on the screen.
4. Press the CHANNEL button until the desired channel appears on the screen.
5. Move the selected channel stick or switch in the direction that you want to adjust the travel. Press the INCREASE or DECREASE button to achieve the desired travel. Move the stick in the opposite direction to adjust the travel in the opposite direction.
6. The same may be done for all channels.
7. Press the MODE button to access the aileron to rudder mixing function.
8. To exit, press the MODE and CHANNEL buttons simultaneously.



7.6

AILERON TO RUDDER MIXING • Function Mode

On some types of aircraft, it is desirable to mix aileron and rudder to make coordinated turns. The XP652 allows the mixing of ailerons to rudder and allows you to adjust the amount and direction of

mixing. The aileron to rudder mixing can be left on all the time, or it can be turned off with the selection of one of three switches.

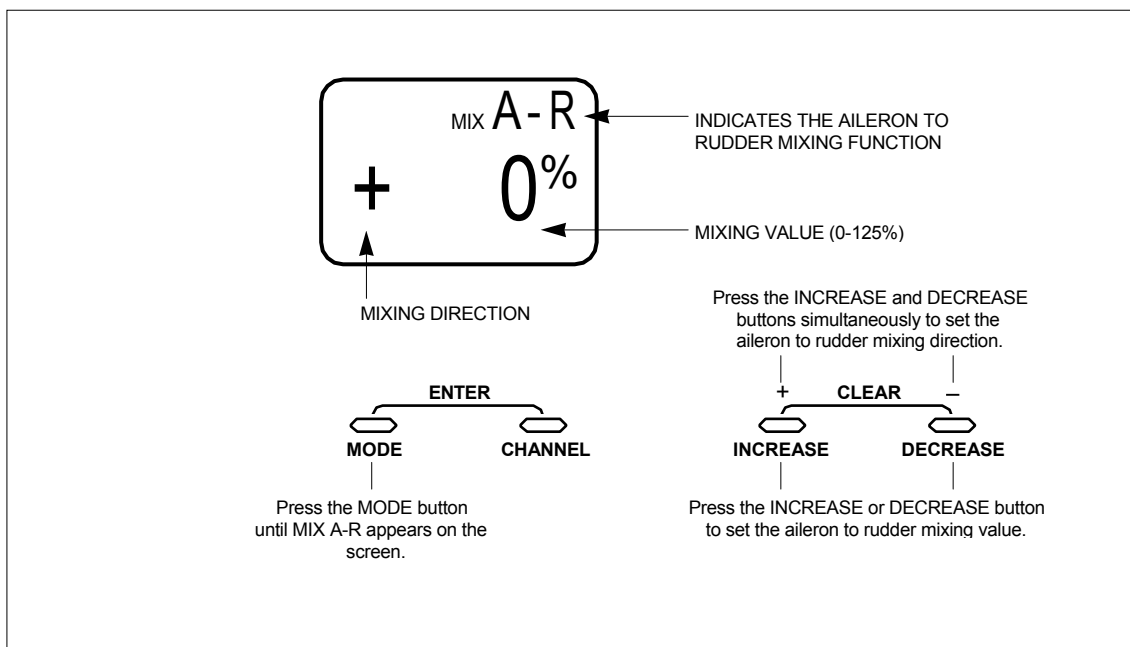

Accessing the Aileron to Rudder Mixing Function

1. Turn on the transmitter.
2. Press the MODE and CHANNEL buttons simultaneously to enter the function mode.
3. Press the MODE button until MIX A-R appears on the screen.
4. Press the INCREASE or DECREASE button to set

the desired amount and direction of aileron to rudder mixing.

Note: If OF appears on the screen it is because the aileron to rudder mixing switch is in the off position.



7.6 AILERON TO RUDDER MIXING (continued)

AILERON TO RUDDER MIXING SWITCH SELECTION

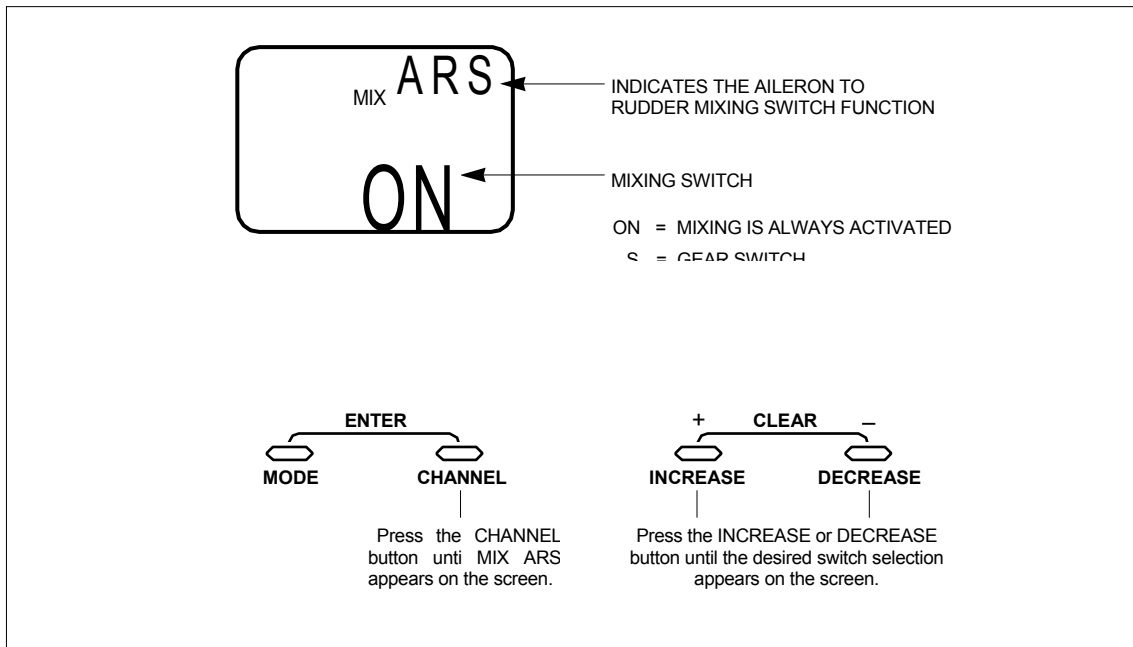

Accessing the Aileron to Rudder Mixing Switch Function

1. Follow Steps 1 through 4 as above.
2. Press the CHANNEL button until MIX ARS appears on the screen.
3. Press the INCREASE or DECREASE button until the desired switch selection appears on the screen.
4. Press the MODE button to access the elevator to flap mixing function.
5. To exit, press the MODE and CHANNEL buttons simultaneously.



7.7

ELEVATOR TO FLAP MIXING • FUNCTION MODE

Elevator to flap mixing is commonly used to quicken the pitching rate of an aircraft. This is very popular in fun fly airplanes because it allows

tighter loops. Normally, with up elevator the flaps go down, while down elevator makes the flaps go up.

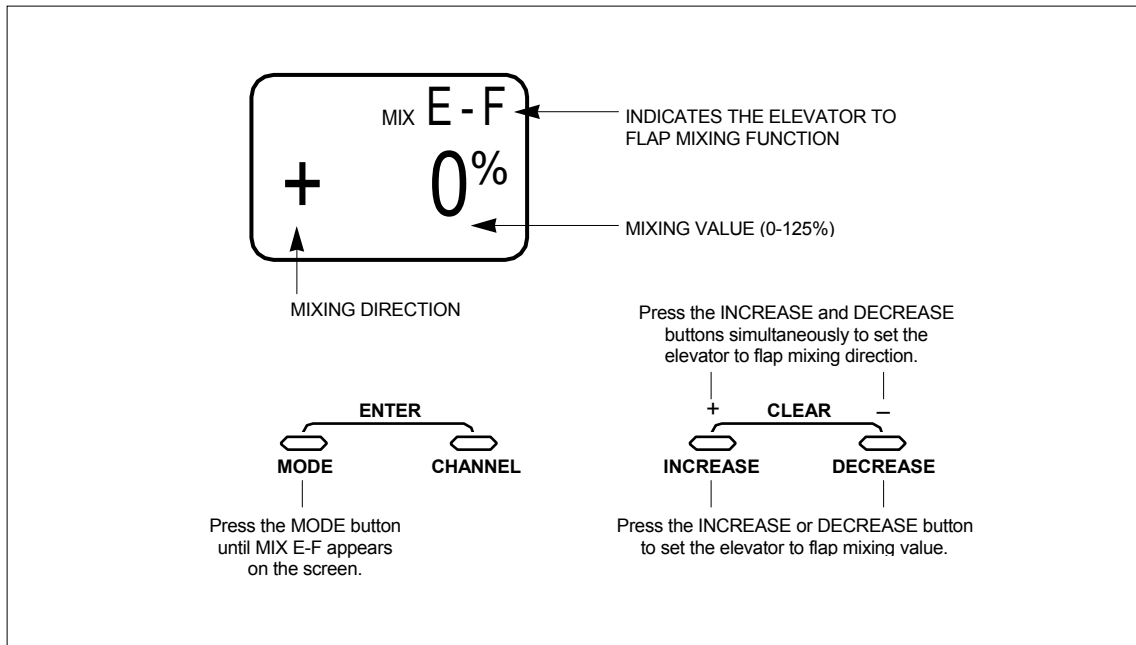

Accessing the Elevator to Flap Mixing Function

1. Turn on the transmitter.
2. Press the MODE and CHANNEL buttons simultaneously to enter the function mode.
3. Press the MODE button until MIX E-F appears on the screen.
4. Press the INCREASE or DECREASE button to set the elevator to flap mixing value.
5. Press the INCREASE and DECREASE buttons simultaneously to set the elevator to flap mixing direction.



7.7 ELEVATOR TO FLAP MIXING (continued)

ELEVATOR TO FLAP MIXING SWITCH SELECTION

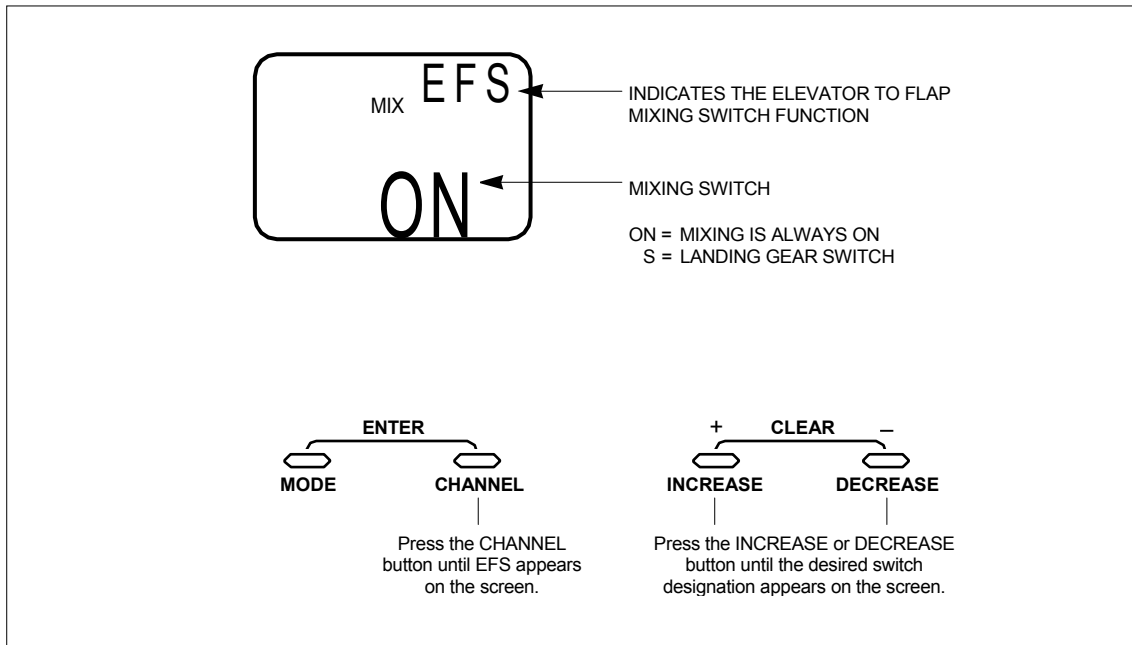

Accessing the Elevator to Flap Mixing Switch Function

1. Follows Steps 1 through 4 as above.
2. Press the CHANNEL button until MIX EFS appears on the screen.
3. Press the INCREASE or DECREASE button until the desired switch designation appears on the screen.
4. Press the MODE button to access the differential function if flaperons or delta wing types are activated in the system mode. If flaperons are not activated, pressing the MODE button will access the flap to elevator offset function.
5. To exit, press the MODE and CHANNEL buttons simultaneously.



7.8 DIFFERENTIAL • Function Mode

Aileron differential is used to correct roll to yaw coupling and adverse yaw characteristics. In order to activate differential, the flaperon wing type must have been selected in the system mode (see Section 6.4). Also, each aileron control surface must have its

own servo with the right aileron servo plugged into the aileron channel (#2) on the receiver and the left aileron servo plugged into the Flap Aux 1 channel (#6) on the receiver.

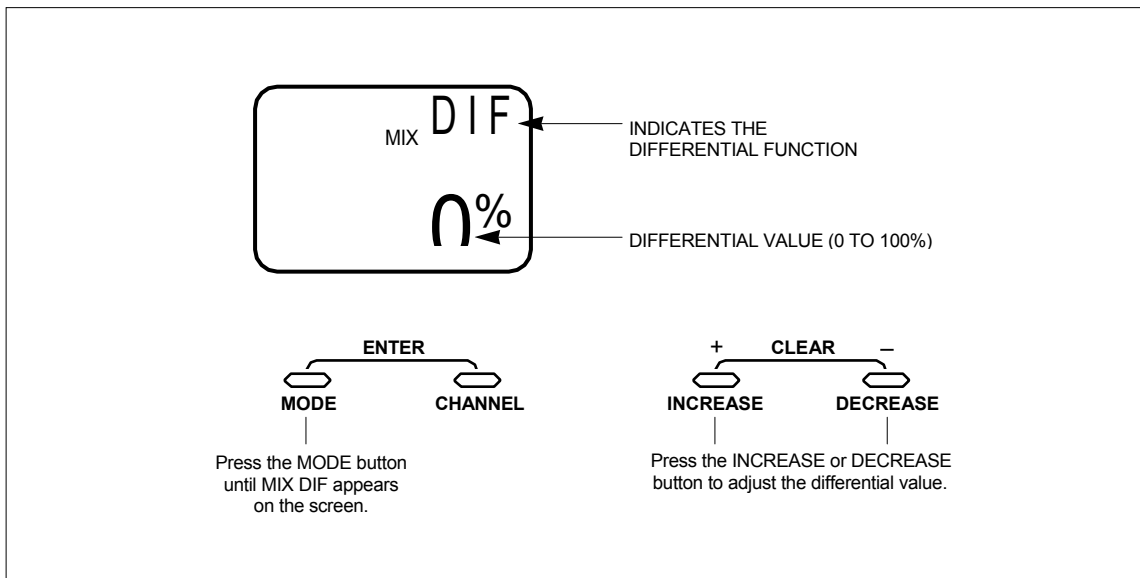

Accessing the Differential Function • Flaperon/Delta Mode Only

1. Turn on the transmitter.
2. Flaperon wing type must be selected (see Section 6.4).
3. Press the MODE and CHANNEL buttons simultaneously to enter the function mode.
4. Press the MODE button until MIX DIF appears on the screen.
5. Press the INCREASE or DECREASE button to adjust the differential mixing value.
6. Press the MODE button to access the flap to elevator offset trim function.
7. To exit, press the MODE and CHANNEL buttons simultaneously.



7.9 FLAP TO ELEVATOR OFFSET TRIM • Function Mode

When the flaps are deployed, most airplanes exhibit pitching tendencies (most pitch nose up). Elevator offset trim is designed to prevent this pitching. Flap to elevator offset trim automatically retrims the elevator to a preset value when the flap switch is activated.

Note: Flap to elevator offset trim is also useful as a dual elevator trim even for airplanes without flaps. This is especially helpful for sailplanes that require one trim setting for launch and another trim setting for flight.

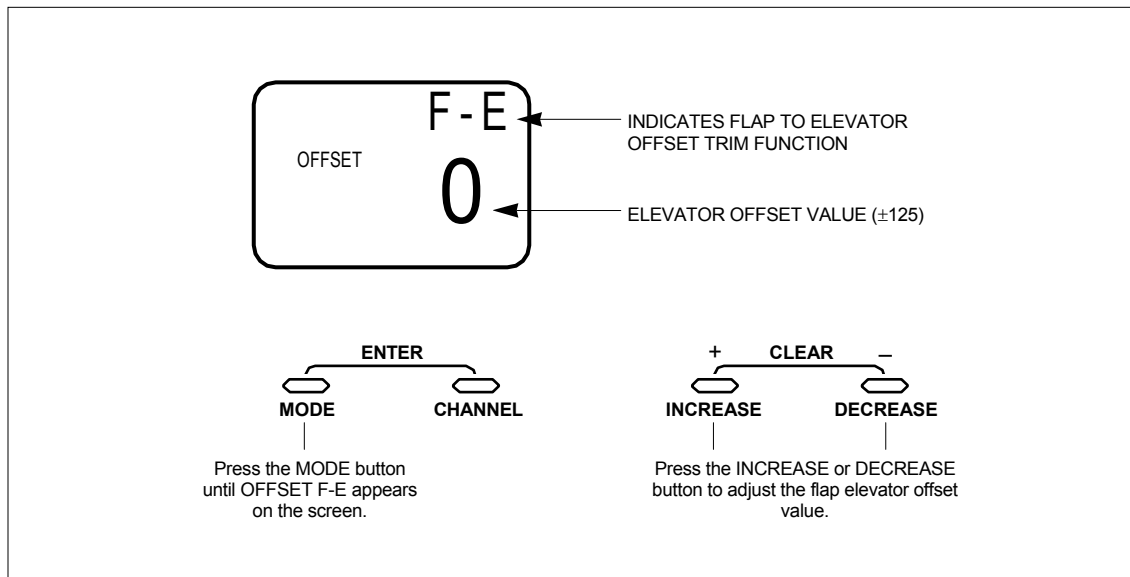

Accessing the Flap to Elevator Offset Trim Function

1. Turn on the transmitter.
2. Press the MODE and CHANNEL buttons simultaneously to enter the function mode.
3. Press the MODE button until OFFSET F-E appears on the screen.
4. Press the INCREASE or DECREASE button to set the desired amount and direction of the elevator offset.

- Note:** It is helpful to have the flap switch on when making this adjustment.
5. Press the MODE button to access the programmable mix function.
 6. To exit, press the MODE and CHANNEL buttons simultaneously.



7.10 PROGRAMMABLE MIXING (A,B,C) • Function Mode

The XP652 in aircraft mode offers three (3) programmable mixes to be used for a number of different purposes. The functions allow mixing any one channel to any other channel.

The mix can remain ON at all times, or be switched OFF in flight using a number of different switches. (Refer to Chart A). Each channel is identified by channel numbers 1-6 (i.e., 2 = aileron, 4 = rudder, etc. — See Chart B) The channel appearing first is known as the “master channel,” or the channel to which you want to mix. The second channel is known

as the “slave channel,” or the channel that is being mixed into the master channel. For example, AILERUDD would indicate aileron to rudder mixing. Each time the aileron stick is moved, the aileron will deflect, and the rudder will automatically move in the direction and to the value input. Mixing is proportional, so small inputs of the master channel will produce small outputs of the slave channel. Each programmable mix has a mixing “offset.” The purpose of the mixing offset is to redefine the neutral position of the slave channel.

Chart A Switch Selection
MIX

SWITCH	A	B	C
Always ON Flap/Mix Switch	ON	ON	ON
Position 1 ON Aileron DIR Switch	F1	F1	F1
Elevator DIR Switch	A	A	/
	E	E	/
Flap/Mix Switch Position 0 ON	/	/	F0
Gear/Mix Switch	/	/	5

Chart B Channel Numbers

CHANNEL NUMBER	FUNCTION
1	Throttle
2	Aileron
3	Elevator Rudder Gear
4	
5	
6	Flap

Accessing the Programmable Mixing Function

1. Turn on the transmitter
2. Press the MODE and CHANNEL buttons simultaneously to enter the Function Mode
3. Press the MODE button until MIX A11 appears at

the top right corner of the screen. This is Program Mix A. Pressing the MODE button again will select mixes B and C.

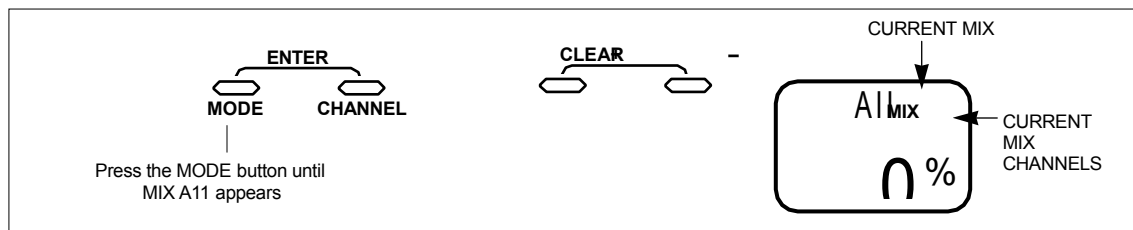

7.10 PROGRAMMABLE MIXING (A,B,C) • Function Mode (continued)

Assigning Channels

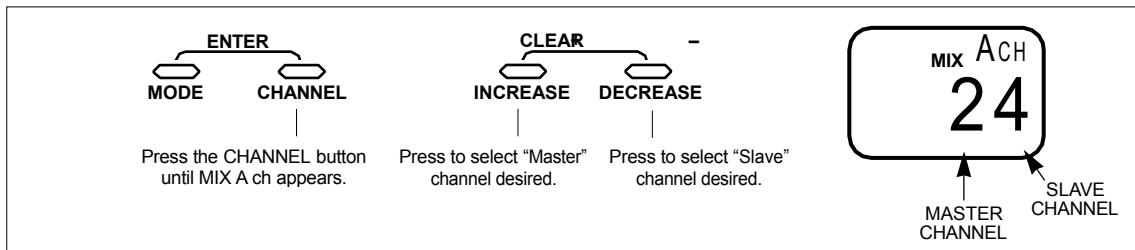

1. Press the channel button twice until MIX A CH appears on the screen.
2. Press the + button to select the desired "Master Channel" (1-6).
3. Press the - button to select the desired "slave channel" (1-6). Refer to Chart B on the preceding page for channel number clarification.

Switch Selection

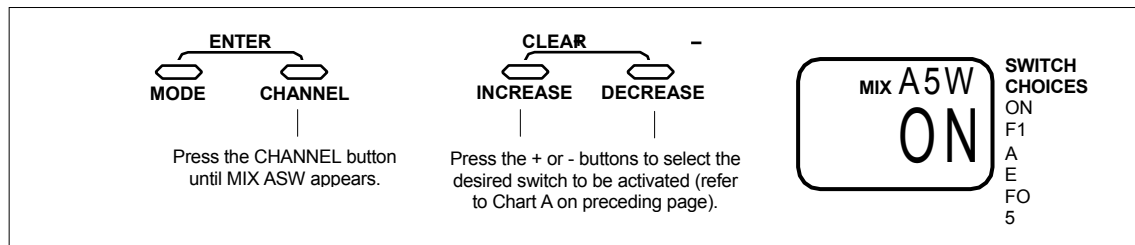

1. Press the CHANNEL button once until MIX ASW appears.
2. Press the + or - button to select the desired switch to be used to activate the mixing, or leave as ON if a constant mix is desired. (Refer to Chart A on the preceding page for possible mix/switch selections.)



7.10 PROGRAMMABLE MIXING (A,B,C) • Function Mode (continued)

Mixing Value Adjustment

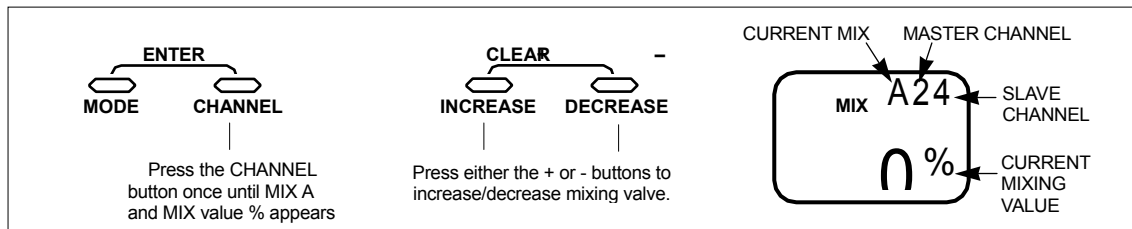

1. Press the CHANNEL button once until MIX A appears, with the mixing value located at the bottom of the screen.
2. To set the slave channels mixing value, move and hold the master channel control stick to the direction to be adjusted (up/down — left/right), then press the + key to add + mixing value, or the - key to add - mixing value (+/-125%). When the

master channels stick is moved, the display will automatically show the mixing valve for the current stick direction.

Note: If a mix switch position other than ON is selected, it will be necessary to move the selected switch to the ON, or active, position to adjust the mixing value. OF will appear on the screen if the selected mixing switch is in the off position.

Mixing Offset Adjustment

The purpose of the mixing offset feature is to redefine the neutral position of the slave channel to be mixed. Any desired position may be selected for the offset reference point. To set the offset position, place the master channel's stick to the desired position and press either the + or - keys.

This position is now stored in the memory and its offset value from the neutral position of the master channel is indicated numerically on the LCD display. Then, the mixing value at the determined offset position is now set at 0.

Accessing the Offset Function

1. Press the CHANNEL button once until offset appears in the center of the screen.
2. Place the master channel stick to the desired position of slave channel offset, then press either the + or - button to store.
3. Press the MODE button once to access Program Mix B, press twice to access program MIX C, and a third time to access the trim offset memory

function.

4. To exit the Function Mode, press the Mode and CHANNEL buttons simultaneously.

Note: If a mix switch position other than ON has been selected, it will be necessary to move the selected switch to the ON, or active, position to set the offset value. OF will appear on the screen if the selected mixing switch is in the OFF position.

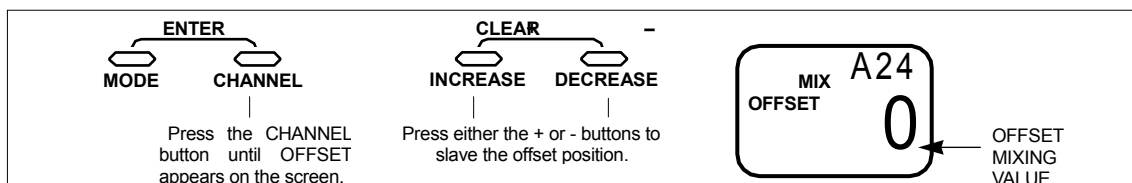

7.11 TRIM OFFSET MEMORY

The Trim Offset Memory Function of your XP652 allows you to test fly your aircraft and correct for any built-in trim requirements. After you adjust the aileron, elevator and/or rudder trim levers during the test flights, the trim levers are no longer in their center, or neutral, positions. The use of trim offset allows you to return the trims to their center, or neutral, positions without readjusting the control surface linkages mechanically.

This function is very useful when switching from model to model. It allows your trims to remain in their neutral positions while retaining their corrections. Using this feature, you can easily switch among the five (5) model memories without the need to readjust for each aircraft's individual trim requirements.

Accessing the Trim Offset Memory Function

1. First, test fly your aircraft and adjust the aileron, elevator and/or rudder trim levers. After all adjustments have been made, land your airplane. DO NOT adjust/reposition any of the trim levers at this time.
2. Turn on the transmitter.
3. Press the MODE and CHANNEL buttons simultaneously to enter the Function Mode.
4. Press the MODE button until TRM offset appears on the screen.

CAUTION: Do not attempt to adjust the Trim Offset Memory Function while your model's engine is running. Please stop your aircraft's engine before entering the Function Mode.

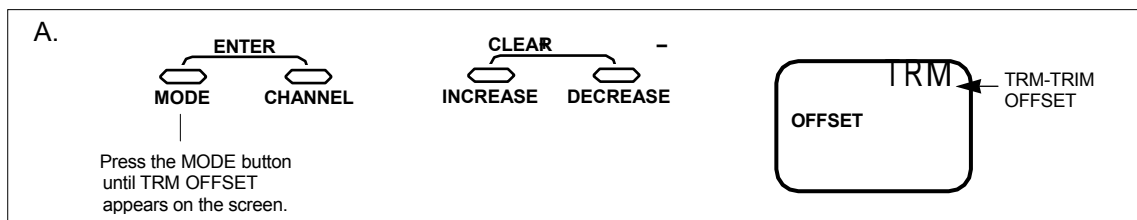

Accessing the Trim Offset Memory Function

5. Press the + or - keys. MOV + CL should appear on the screen.

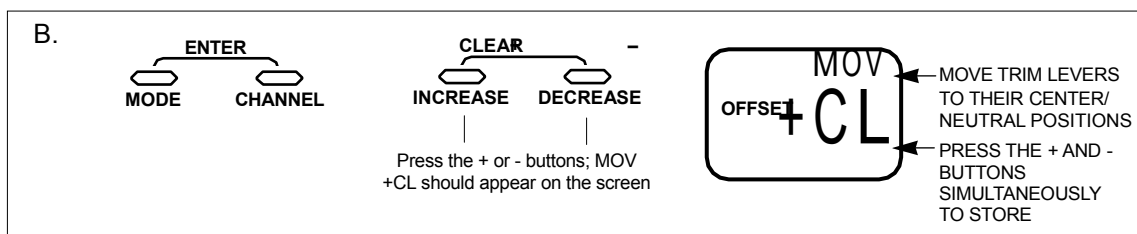

7.11 TRIM OFFSET MEMORY (continued)

Accessing the Trim Offset Memory Function (continued)

6. Move all trim levers to their center positions, then press the + and - buttons simultaneously to store the trim offsets. The screen should appear as shown:
7. Press the MODE and CHANNEL buttons simultaneously to exit the function mode.

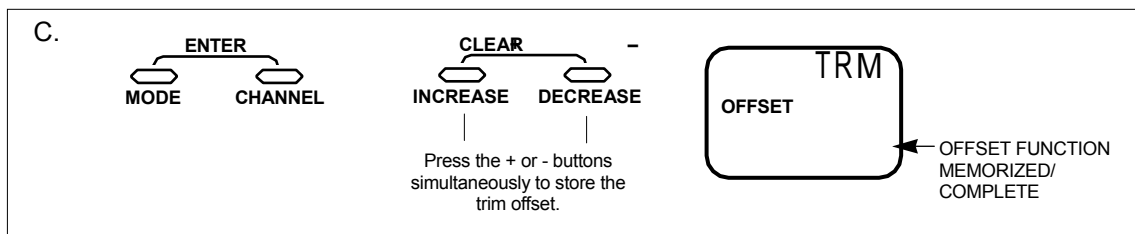

Over Trim

If OVR appears on the screen when the trim levers are moved to their center positions, this indicates that the amount of offset trim for one or more channels is in

excess of the acceptable limits. If this situation occurs, a mechanical adjustment of the control linkage will be necessary.

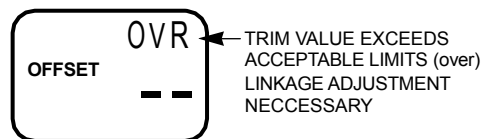

Clearing Trim Offset Memory

This feature is useful if you wish to clear all trim offset stored within the XP652's memory without affecting the data stored for other functions. The most common use for this feature is if you have disassembled/

repaired your model and would like to return all servos/trims to their "true neutral" positions before linkage installation/initial test flights.



7.11 TRIM OFFSET MEMORY (continued)

Accessing the Offset Trim Clear Function

1. Turn on the transmitter
2. Press the MODE and CHANNEL buttons simultaneously to enter the Function Mode.
3. Press the MODE button until TRM OFFSET appears on the screen.

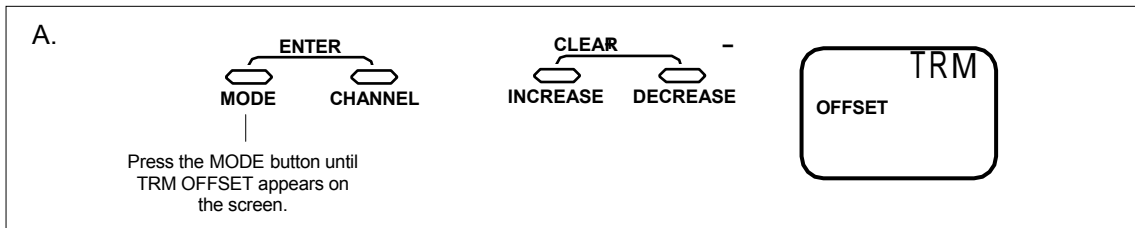

4. Press the CHANNEL button once; CL should appear at the bottom of the screen:

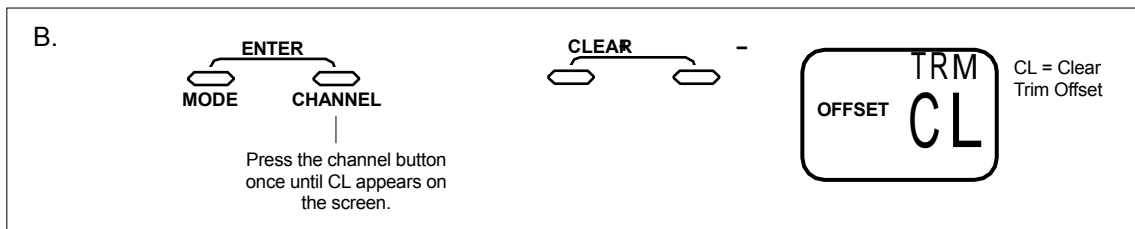

5. Press the + and - buttons simultaneously .0 should appear on the screen indicating that the offset trim memory has been reset to 0, or neutral trim.
6. Press the MODE and CHANNEL buttons simultaneously to exit the function mode.

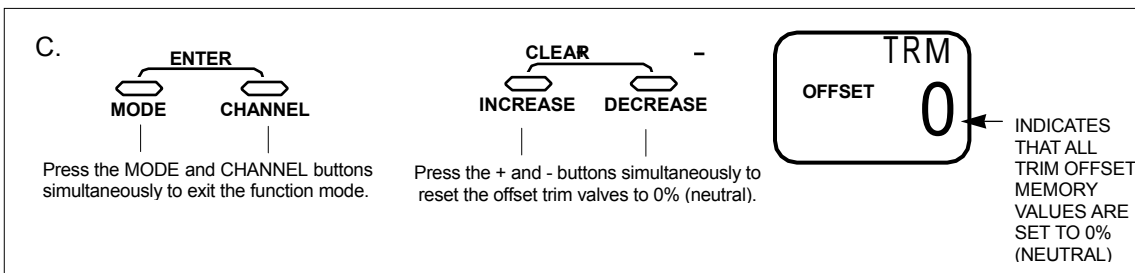

CHAPTER 8: DATA SHEET • XP652 Airplane

8

DATA SHEETS

Modulation SPCM • ZPCM • PPM (FM)

Model Number _____

Model Name _____

CHANNELS	THRO (1)		AIL (2)		ELE (3)		RUDD (4)		GER (5)		AUX1 (6)	
	NORM		NORM		NORM		NORM		NORM		NORM	
REVERSE SW	•		•	REV	•	REV	•	REV	•	REV	•	REV
SUB TRIM												
TRAVEL ADJUST	+	%	+	%	+	%	+	%	+	%	+	%
(TRV ADJ.)	-	%	-	%	-	%	-	%	-	%	-	%
FAIL SAFE (SPCM)												

FAIL SAFE TIME (ZPCM)	
-----------------------	--

D/R SW	EA • A • E • CF
--------	-----------------

LANDING ELEV OFFSET	±
---------------------	---

WING TYPE	NORM • FLAPERON • DELTA
V-TAIL	ON • OFF

DIFFERENTIAL	%
--------------	---

			AIL (AI)	ELEV (EL)
DUAL RATE • EXP	POS 0	D/R	%	%
		EXP	%	%
	POS 1	D/R	%	%
		EXP	%	%

	MIX SW	POS
AIL ELEV → RUDD FLAP MIX	ON • 5 • A • F1	%
ELEV → FLAP MIX	ON • 5 • E • F0	%

TRIM OFFSET	
-------------	--

		CHANNEL		MIX SWITCH	OFFSET	+GAIN	-GAIN
		MASTER	SLAVE				
PROG. MIX	A	→		ON • F1 • A • E			
	B	→		ON • F1 • A • E			
	C	→		ON • F1 • F0 • 5			



1.1 CONTROL IDENTIFICATION AND LOCATION • Mode II

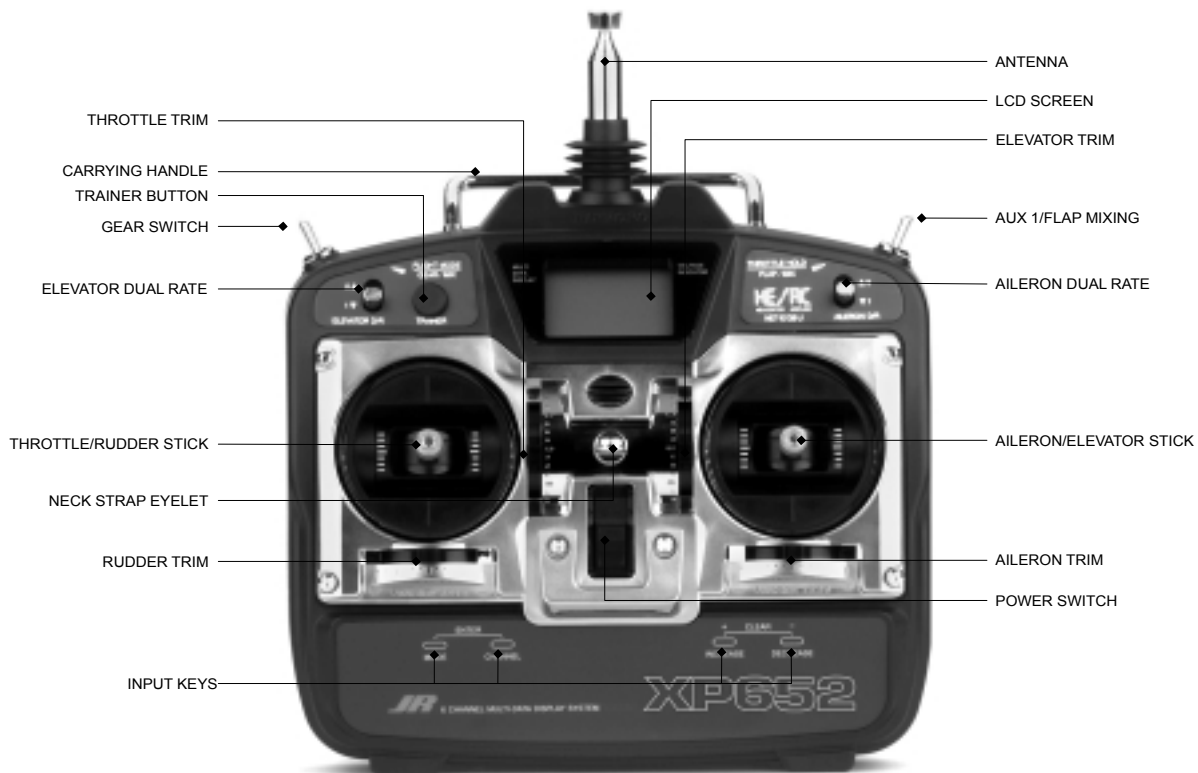

1.2 RECEIVER CHANNEL ASSIGNMENT/TRANSMITTER THROTTLE ALT

- | | | |
|----|-------|-----------------------------|
| 1. | THRO | Throttle Channel |
| 2. | AILE | Aileron Channel |
| 3. | ELEV | Elevator Channel |
| 4. | RUDD | Rudder Channel |
| 5. | GEAR | Gear Channel |
| 6. | AUX 1 | Auxiliary 1 Channel (Pitch) |

Transmitter Throttle ALT

The throttle ALT function makes the throttle stick trim active only when the throttle stick is less than half throttle. This gives easy, accurate idle adjustments without affecting the high throttle position.



1.3 TRANSMITTER REAR

Note: Your transmitter has a 5-year lithium battery to protect your pre-programmed data against main transmitter battery failure. If your system reads 0.0 volts, or has an unfamiliar display (service mode) or

your data resets to the factory defaults, return your transmitter to Horizon Service Center (see page 94) for lithium battery replacement.



1.4 CONTROL STICK LENGTH ADJUSTMENT

To adjust the control stick length, use a 2mm Allen wrench to unlock the set screw located inside the end of the control stick. Turn the set screw counterclockwise to loosen it, then turn the knurled portion of the stick to adjust the length. Counterclockwise will lengthen the stick and clockwise will shorten it. After the control stick(s) has been adjusted to suit your flying style, tighten the set screw back.

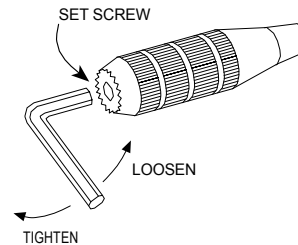

1.5 DIRECT SERVO CONTROL (DSC)

For proper DSC hook-up and operation:

1. Leave the transmitter power switch off. The transmitter will not transmit any radio frequency (RF) in this position.
2. Plug the optional DSC cord (JRPA132) into the DSC port in the rear of the transmitter.
3. The encoder section of the transmitter will now be operational and the LCD display will be lit.
4. Plug the other end of the DSC cord into the receiver charge receptacle. Turn on the switch harness.

Note: When installing the optional charging jack (JRPA024) be sure to hook the charging jack receptacle securely into the switch harness charge cord.

Why you should use the DSC function:

1. The DSC enables you to check the control surfaces of your aircraft without drawing the fully operational 200mAh from your transmitter battery pack. Instead, you will only draw 70mAh when using the DSC function.

Note: You will need to purchase (separately) both the DSC Cord (JRPA132) and the JR Deluxe Switch Harness (JRPA001) to make use of the XP652 DSC Function.

2. The DSC function allows you to make final adjustments to your airplane or helicopter without transmitting any radio signals. Therefore, if another pilot is flying on your frequency, you can still adjust your aircraft and not interfere with the other aircraft.

Note: Under no circumstances should you attempt to fly your aircraft with the DSC cord plugged in! This feature is for bench checking your aircraft only.

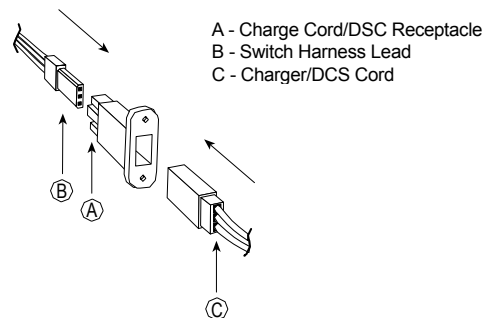

1.6 NECK STRAP ATTACHMENT

There is an eye hook on the front of the transmitter for attaching an optional neck strap (JRPA023). The eye hook is precisely positioned (see Section 1.1) so

that the transmitter will be perfectly balanced when a neck strap is used.



CHAPTER 2: CONNECTIONS • Helicopter

2.1 INSTALLATION REQUIREMENTS

It is important to correctly install the radio system in your model. Please read and carefully follow the suggestions listed below.

1. For added protection, wrap the Rx and the Rx Nicad in foam rubber that is at least 1/4" thick.
2. Run the Rx antenna through the fuselage and make sure it is fully extended. Never cut or bundle your Rx antenna — this will decrease range and performance.
3. Rubber servo grommets are included with your radio system and should be installed in the servo flanges. The servos should then be mounted on either hardwood rails or a plywood tray with the mounting screws provided. **Do not overtighten the mounting screws.** The flange of the brass eyelets should face down (toward the wood).
4. All servos must be able to move freely over the full range of their travel. Make sure the linkages do not impede servo travel. A stalled servo will drain the battery pack within a few minutes.
5. Before installing servo output arms, make sure the servo is in its neutral position.
6. In the case of gas-powered model aircraft, mount the receiver power switch on the side of the fuselage opposite the muffler to protect the switch from exhaust residue. With other types of models, mount the switch in the most convenient place. Make sure that the switch operates freely and is capable of traveling its full distance.
7. **With your model sitting on the ground and the transmitter antenna collapsed, check that your system works at a distance of 75 to 100 feet.** If your system stops functioning at a distance that is shorter than listed above, please contact the Horizon Service Center for further information prior to flying your model.

2.2 CONNECTIONS

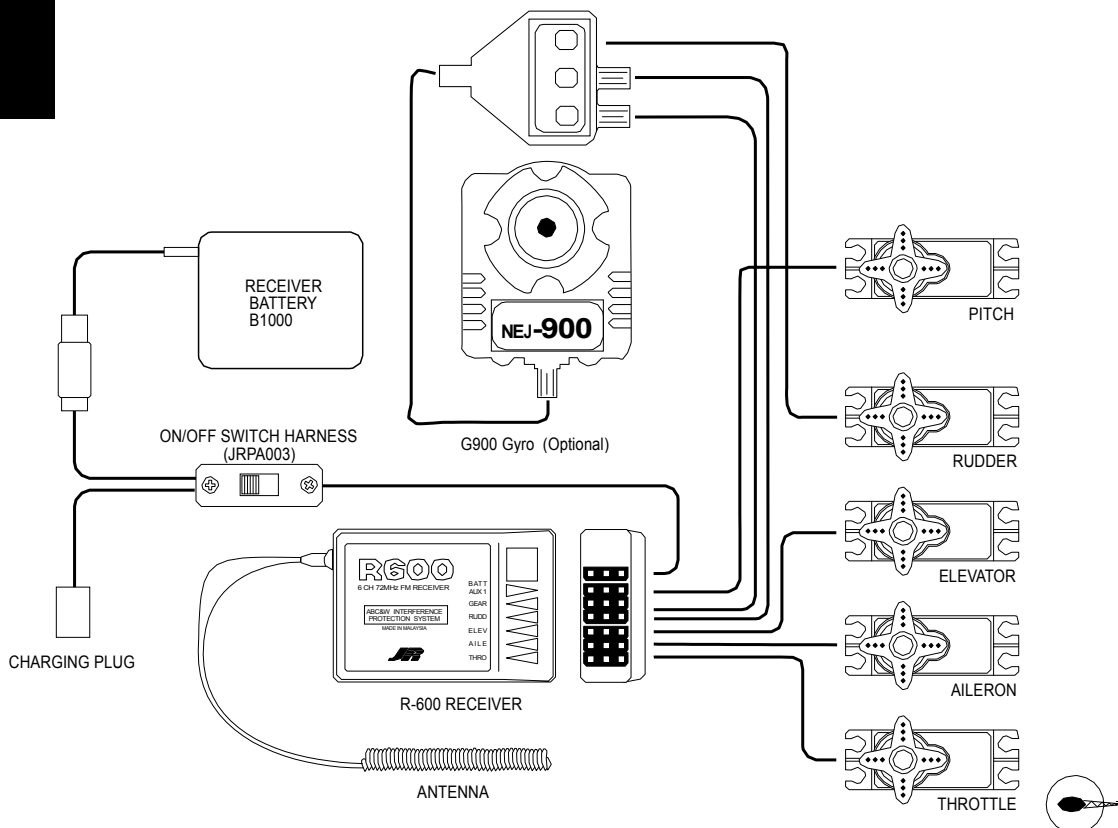

CHAPTER 3: KEY INPUT AND DISPLAY • Helicopter

3

KEY INPUT AND DISPLAY

BUTTON	USE
MODE	Used to move up through the available functions
CHANNEL	Used to select the desired channel
INCREASE	Used to increase the value of the selected function
DECREASE	Used to decrease the value of the selected function

To enter the system mode press the MODE and CHANNEL buttons simultaneously and hold while turning on the transmitter.

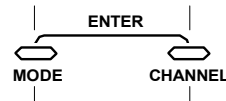

To enter the function mode press the MODE and CHANNEL buttons simultaneously while the transmitter is on.

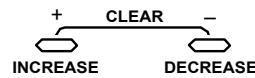

Press the INCREASE and DECREASE buttons simultaneously to clear the screen or return to factory preset.

CHAPTER 4: BATTERY ALARM AND DISPLAY • Helicopter

4

BATTERY ALARM AND DISPLAY

When the transmitter battery drops below 9.0 volts, the display will start to flash BAT and an audible alarm will sound for 8 beeps. These warnings mean you should land your aircraft immediately.

Note: During the period that the battery alarm is flashing, the input buttons will not function. If you are currently in the function mode, the transmitter will exit automatically and return to the normal display (see Section 5.1).

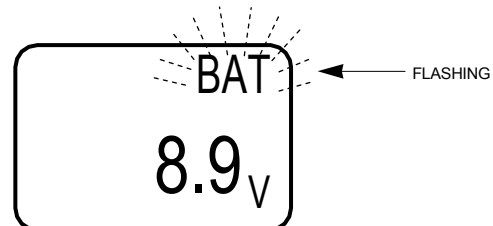

CHAPTER 5: INPUT MODE AND FUNCTION • Helicopter

5.1 NORMAL DISPLAY

When the power switch is turned on the screen will read as shown here in the diagram. This screen is referred to as the normal display.

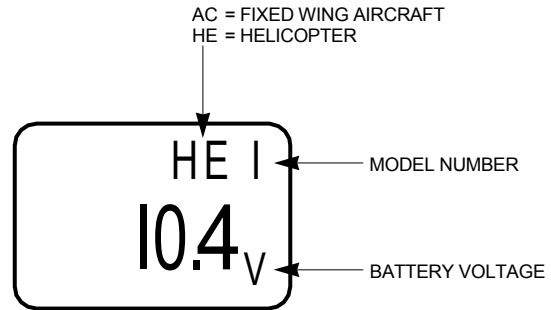

5.2 SYSTEM MODE

To enter the system mode press the MODE and CHANNEL buttons simultaneously while you turn on the transmitter. You can now select any of 8 system mode functions shown here in the flow chart. To exit the system mode, press the MODE and CHANNEL buttons simultaneously or turn off the transmitter. Press the MODE button to move through the system mode functions. Information for each function is located on the page number listed next to the function name.

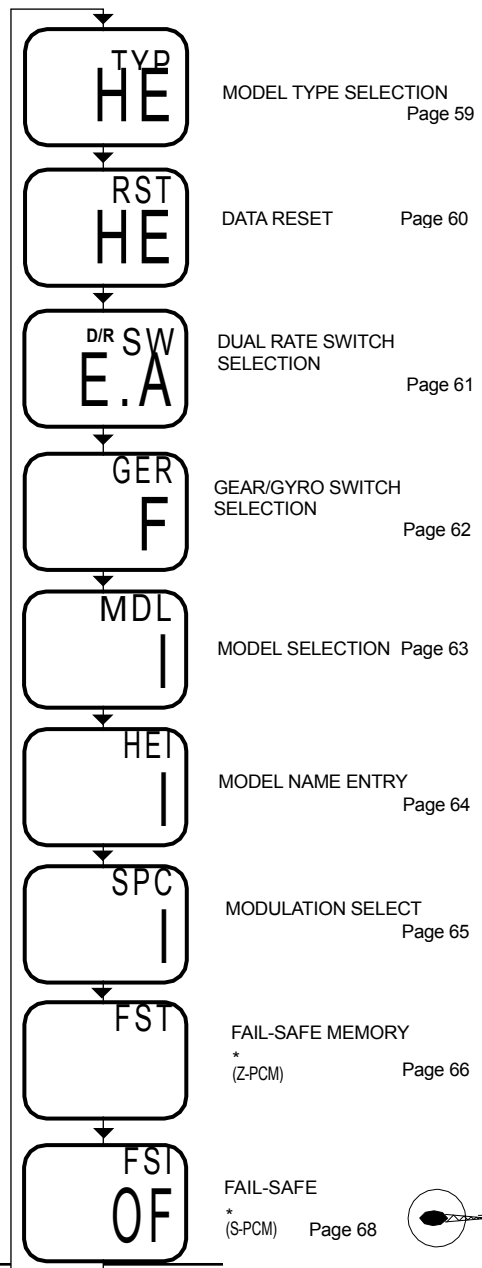

* Only visible when modulation type is selected for SPCM, or ZPCM modulation

CHAPTER 5: INPUT MODE AND FUNCTION

5.3 FUNCTION MODE

To enter the function mode, turn on the transmitter. Press the MODE and CHANNEL buttons simultaneously until a beep is heard. The display will change accordingly and show the last active function. Press the MODE button to scroll down through the functions one by one as shown in the flowchart at right. Once the appropriate function is selected, use the CHANNEL button to select the appropriate channel. Use the INCREASE and DECREASE buttons to adjust the values displayed on the screen.

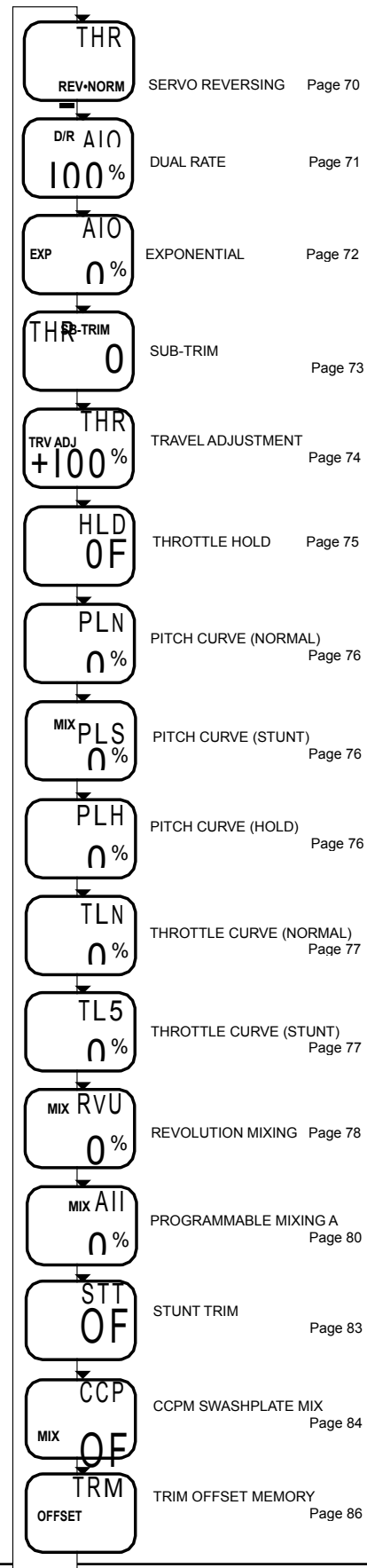

CHAPTER 6: FUNCTIONS • Helicopter (System Mode)

6.1 MODEL TYPE SELECTION • System Mode

Two types of aircraft programming are available with the XP652, airplane (AC) and helicopter (HE). When you enter the model type selection function, the current model type will appear on the screen. (The current model type being the factory preset or the last model used.) When you press the increase or decrease button to change the model type, the new

model type indicated on the screen will flash. For example, if the current model type is AC and you change to HE, HE will flash on the screen. The flashing alerts you to the change of model type and will stop once you move to the next function or exit the system mode.

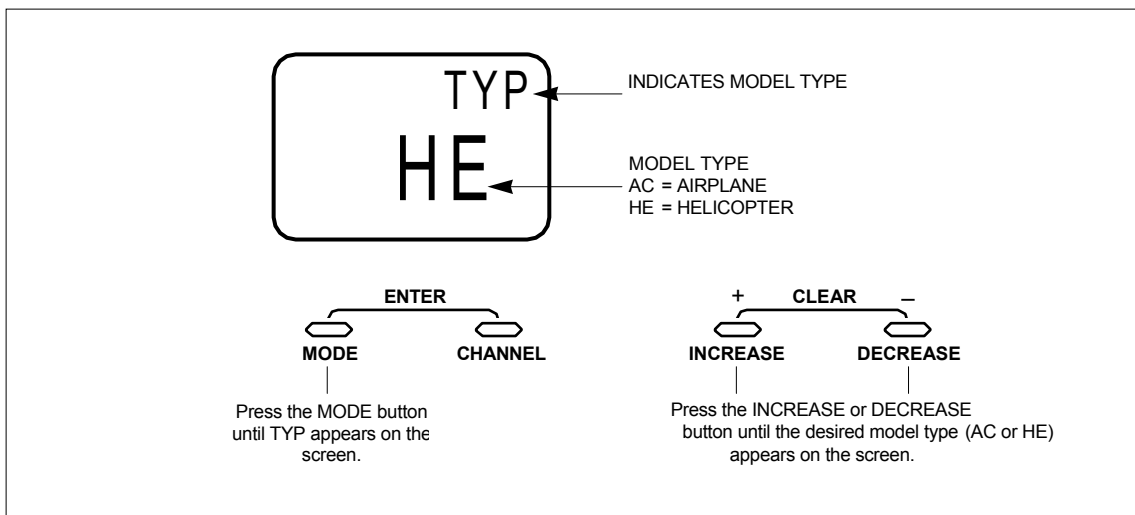

Accessing the Model Type Selection Function

1. Press the MODE and CHANNEL buttons simultaneously and hold.
2. Turn on the transmitter to enter the system mode.
3. Press the MODE button until TYP appears on the screen.
4. Press the INCREASE or DECREASE button until the desired model type appears on the screen (AC = airplane HE = helicopter).
5. Press the MODE button to access the data reset function.
6. To exit, press the MODE and CHANNEL buttons simultaneously.



6.2 DATA RESET • System Mode

The data reset function allows you to reset all the programming in the selected model (1-5) to the factory settings. Before using the data reset function it is important to enter the model selection function and check that the current

model number (1-5) indicated is the model that you want to reprogram to the factory settings. The model selection function is described in Section 6.5.

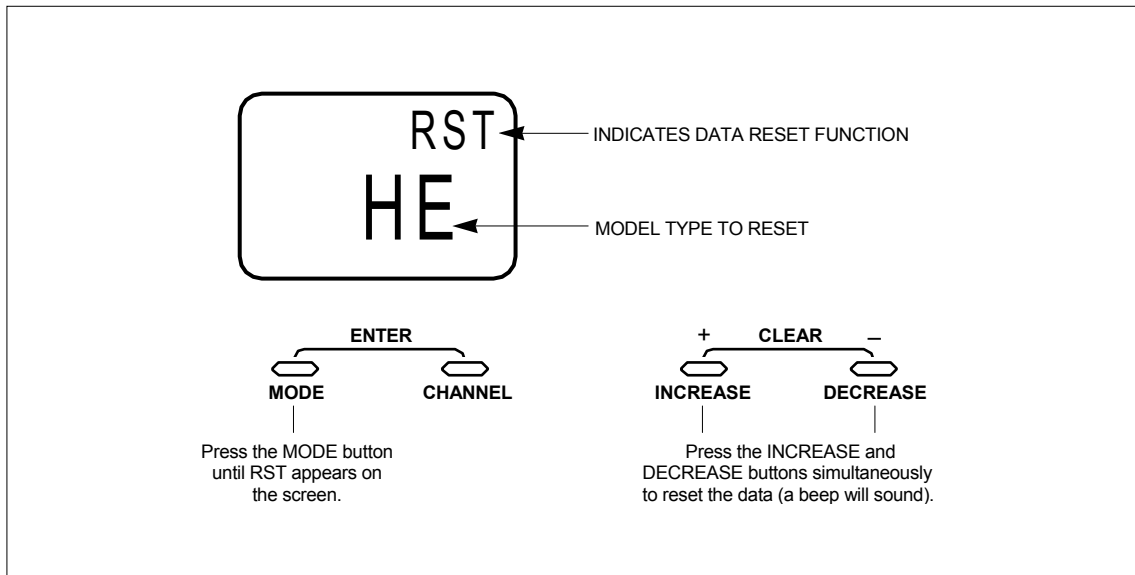

Accessing the Data Reset Function

1. Press the MODE and CHANNEL buttons simultaneously and hold.
2. Turn on the transmitter to enter the system mode.
3. Press the MODE button until RST appears on the screen.
4. Press the INCREASE and DECREASE buttons simultaneously to reset the data. (To confirm that the selected model's programming has been reset, a beep will sound and the AC or HE will momentarily disappear from the screen.)
5. Press the MODE button to access the dual rate switch selection function.
6. To exit, press the MODE and CHANNEL buttons simultaneously.



6.3 DUAL RATE SWITCH SELECTION • System Mode

The dual rate switch position is selectable and the elevator and aileron dual rates can be combined on one switch. This allows a single switch to be used when moving from high rates for wild maneuvers to low rates for mild maneuvers. Exponential Rate (EXP) is also available for both aileron and elevator and works in conjunction with the dual rate function to

provide mild control movements around neutral while allowing maximum servo travel. This reduces sensitivity in the middle portion of the stick control and still allows full travel at the end of the stick control. Refer to section 7.3 for exponential rate adjustment.

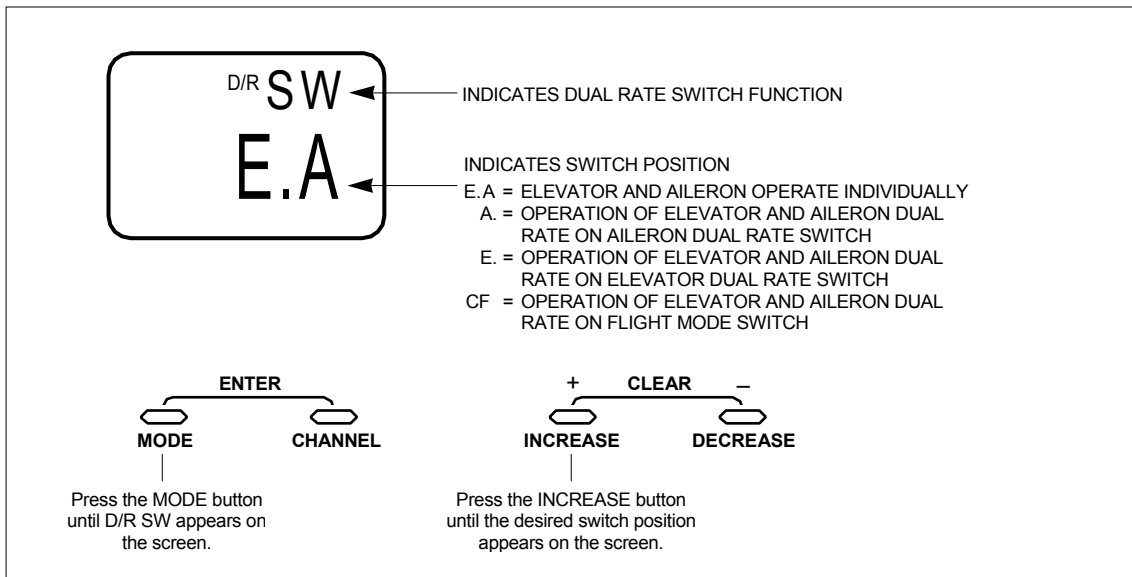

Accessing the Dual Rate Switch Selection Function

1. Press the MODE and CHANNEL buttons simultaneously and hold.
2. Turn on the transmitter to enter the system mode.
3. Press the MODE button until D/R SW appears on the screen.
4. Press the INCREASE button until the desired switch position, or CF for VTR, appears on the screen. To adjust the dual rate values see Section 7.2.
5. Press the MODE button to access the GER/GYRO SWITCH SELECTION function.
6. To exit, press the MODE and CHANNEL buttons simultaneously.



6.4 GEAR/GYRO SWITCH SELECTION • System Mode

The XP652 gear/gyro switch selection function enables the dual rate values of the gyro to be combined with one of four switches (flight mode, throttle hold, aileron dual rate, elevator dual rate). This feature is for use with gyros that offer a dual rate sensitivity adjustment such as the JRNEJ-900 Piezo Gyro

(JRPG900). The most common use for this feature would be to combine the gyro dual rate adjustment with the flight mode switch. This would then automatically alter the gyro sensitivity from normal (hover) to flight (forward flight) when the flight mode switch is in use.

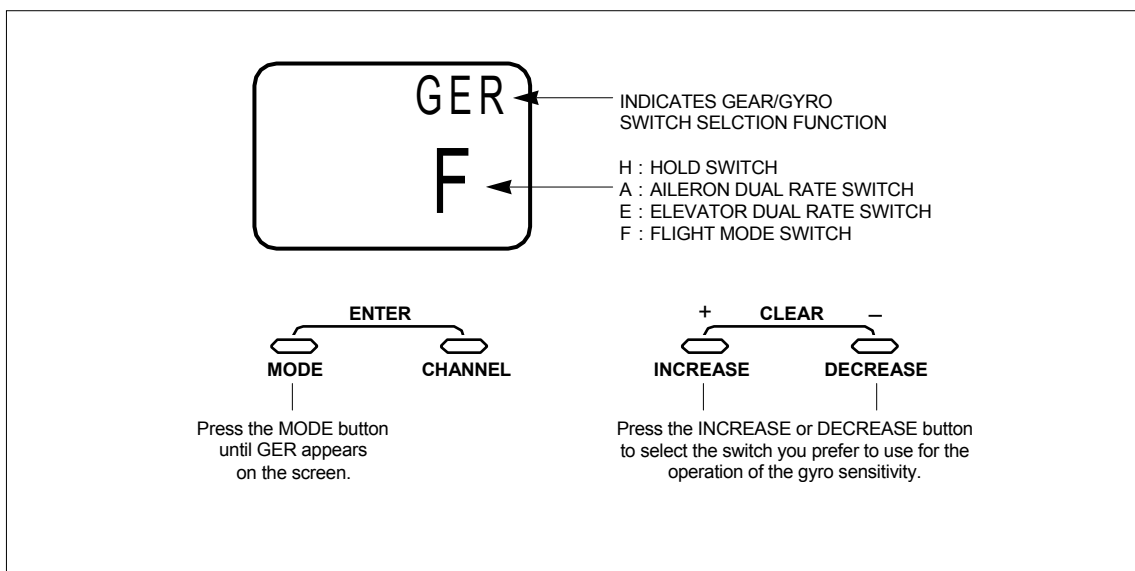

Accessing the Gear/Gyro Switch Selection Function

1. Press the MODE and CHANNEL buttons simultaneously and hold.
2. Turn on the transmitter to enter the system mode.
3. Press the MODE button until GER appears on the screen.
4. Press the INCREASE button to select the switch you prefer to use for the operation of the gyro sensitivity.
5. Press the MODE button to access the model selection function.
6. To exit, press the MODE and CHANNEL buttons simultaneously.

Note: The remote gain lead from the gyro should be plugged into channel 5 (Gear) of the receiver.



6.5 MODEL SELECTION • System Mode

The XP652 has memory for five models. It can store the settings for five airplanes, five helicopters or two airplanes and three helicopters, etc.

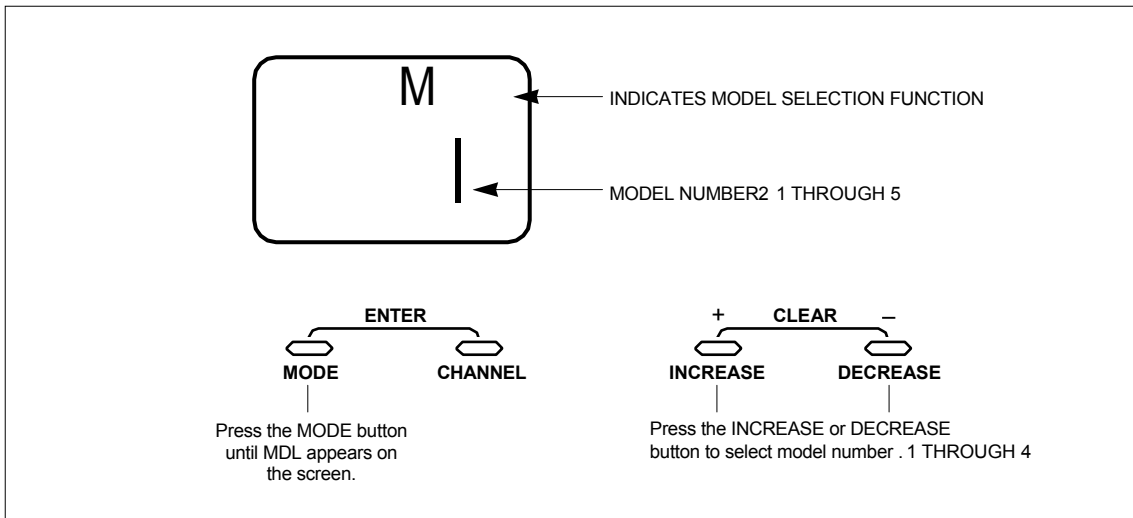

Accessing the Model Selection Function

1. Press the MODE and CHANNEL buttons simultaneously and hold.
2. Turn on the transmitter to enter the system mode.
3. Press the MODE button until MDL appears on the screen.
4. Press the INCREASE or DECREASE button to select model numbers 1 through 5.
5. Press the MODE button to access the model name entry function.
6. To exit, press the MODE and CHANNEL buttons simultaneously.



6.6 MODEL NAME ENTRY • System Mode

The XP652 allows a 3 digit name to be input for each of the five (5) models available. The current model will be displayed in the normal

display. This feature is useful to help identify different aircraft types, or model setups.

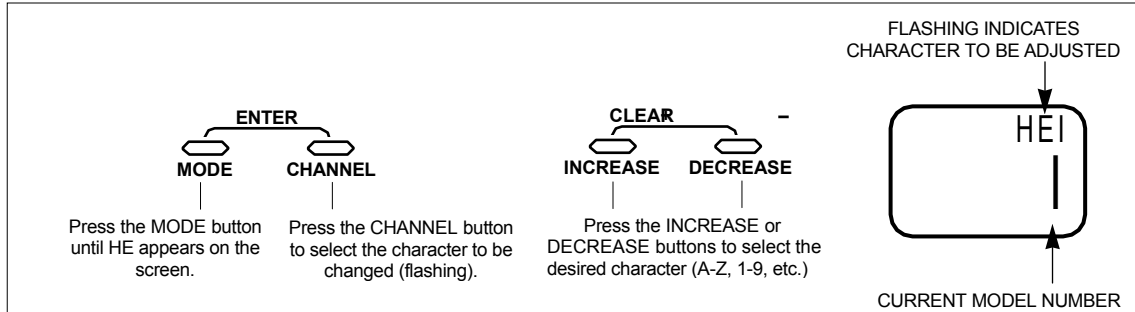

Accessing the Model Name Entry Function

1. Press the MODE and CHANNEL buttons simultaneously and hold.
2. Turn on the transmitter to enter the System Mode.
3. Press the MODE button until AC1 appears on the screen.
4. Press the INCREASE or DECREASE buttons to select the correct letter/number for the first character (flashing).
5. To adjust the remaining 2 characters, press the CHANNEL button until the desired character to be adjusted is flashing.
6. Press the MODE button to access the Modulation Select Function.
7. To exit, press the MODE and CHANNEL buttons simultaneously.



6.7 MODULATION SELECT • System Mode

The modulation select function enables your XP652 to transmit to a variety of JR receivers that are already, or may soon be, in existence. You can select from either PPM (FM), Z-PCM or S-PCM,

depending on the central processing unit within your receiver to utilize existing receivers, or to upgrade your XP652 flight pack for future models. Your system comes factory preset in the FM or PPM (Pulse Position Modulation) position so that it is compatible with the included R600 FM receiver.

Please refer to the receiver compatibility chart below when selecting the modulation type for various JR receivers.

Note: Once the proper modulation has been selected for a specific model number, the modulation type will remain the same for that model number, even during model number/type changes. In other words, if you have one model on FM/PPM and one model on PCM, the system will automatically change modulation types once the correct modulation has been selected for that model.

Tx Modulation	Compatible Receivers	# of Channels & Brief Description	Tx Modulation	Compatible Receivers	# of Channels & Brief Description
PPM (FM)	NER-226	6 (micro)	Z-PCM	NER-236	6 (micro)
PPM (FM)	NER-228	8	Z-PCM	NER-627XZ or 627 "G" series	7
PPM (FM)	NER-327x	7	Z-PCM	NER-J329P	9
PPM (FM)	NER-527x	7 (micro)	Z-PCM	NER-910XZ	10
PPM (FM)	NER-529x	9 (micro)	S-PCM	NER-D940S	10
PPM (FM)	NER-549	9	S-PCM	NER-649S	9
PPM (FM)	NER-600	6 (micro)	S-PCM	NER-950S	10

Accessing the Modulation Select Function

1. Press the MODE and CHANNEL buttons simultaneously and hold.
2. Turn on the transmitter to enter the System Mode.
3. Press the MODE button until PPM appears on the screen.
4. Press either the INCREASE or DECREASE buttons to change the modulation to the desired setting FM (PPM), Z-PCM (ZPC) or S-PCM (SPC).*
5. Press the MODE button to access the Model Type Function.
6. To exit, press the MODE and CHANNEL buttons simultaneously.

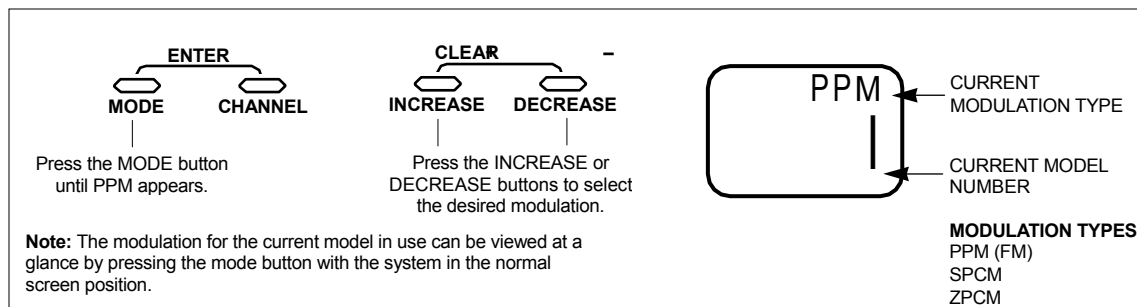

* **Note:** If either S-PCM or Z-PCM modulation is selected, pressing the MODE button will access the fail-safe/hold function.

6.8 FAIL-SAFE/HOLD (System Mode)

The Fail-Safe/Hold Function is available only when you use the XP652 transmitter in either of the PCM modulations — S-PCM or Z-PCM. This function is designed to help minimize damage to your airplane during a loss of signal to the receiver. The servos either assume the fail-safe presets or hold the last good signal position.

Note: In the PCM modulations, the Fail-Safe/Hold Function cannot be totally disabled so that the servos will react to interference in the same way as they do in a PPM system. This is only possible with the use of a PPM receiver and the transmitter in the PPM modulation.

Note: Since the actual screen appearance varies, depending on the modulation of your radio, refer to the appropriate modulation section which follows (Z-PCM, S-PCM).

As noted earlier, if you are in the PPM modulation, the Fail-Safe/Hold Function is not applicable. Therefore, the Fail-Safe/Hold Function will not appear on your LCD in the PPM mode.

Refer to the Modulation Selection Section for more information pertaining to the broadcast signal of your XP652 transmitter.

6.9 FAIL-SAFE/HOLD FUNCTION IN Z-PCM MODULATION (System Mode)

Hold (Z-PCM)

The Hold Function is automatically activated when the radio is turned ON and is in the Z-PCM modulation.

This function stops (or holds) the servos in the positions they were in just prior to the interference. Therefore, your airplane maintains the position held

immediately before the interference was experienced. When a clear signal is restored, the Hold Function releases, and control of the airplane returns to you.

If you would prefer your control surfaces to move to a chosen position during a loss of signal, please refer to the time delay/memory section below.

Accessing Fail-Safe/Hold (Z-PCM)

When the Fail-Safe Function is activated (i.e., when the signal is interrupted), the transmitter automatically moves each servo to a preset position. The position that each servo assumes is determined by you, as is the time length of interference that must occur before servo movement.

After the interference has ceased, control of the airplane returns immediately to you.

There are three time delays to choose from: 1/3 (0.3) second, 1/2(0.5) second and 1.0 second. These time delays are the amount of time it takes, starting the

moment the interference occurs, until the servos assume their preset positions.

1. Press the MODE and CHANNEL button simultaneously and hold.
2. Turn on the transmitter to enter the System Mode.
3. Press the MODE button until FST appears on the screen.

Note: If Fail-Safe does not appear on your LCD, it is because you are transmitting in PPM. Fail-Safe is not applicable in the PPM mode. Refer to the Modulation Mode Selection Section for more information.



6.9 FAIL-SAFE/ HOLD FUNCTION IN Z-PCM MODULATION (continued)

Setting Fail-Safe/Hold Time Delay/Memory In Z-PCM Modulation

1. After accessing the Fail-Safe Function, it is now time to adjust the Fail-Safe Time Presets.
2. Select among the three time delays (.3, .5, or 1.0

seconds) by pressing either the + or - keys until the desired setting appears on the screen.

Setting Servo Position Presets

1. Press the MODE button until FSM appears on the screen.
- Note:** If Hold position is selected (HO) this function/screen will not be present.
2. Set all controls to the desired fail-safe position, then press the + and - buttons simultaneously. A high pitch beep sound will confirm that the preset positions have been entered.
 3. Hold the transmitter sticks in the position that you want the servos to assume during signal loss conditions. You can determine fail-safe preset positions for the other channels by placing the potentiometers and switches in the positions that you want them to assume during interference.
 4. With the sticks, switches and potentiometers in the fail-safe positions, press the + and - keys simultaneously. This will enter these locations as the fail-safe memory settings. A high pitched

- beep will indicate that this setting has been stored.
5. To confirm that the input of data was successful, switch the transmitter OFF. The controls will move to the input locations. If not, repeat step 4 again.
 6. To exit the Fail-Safe Function, press the MODE and CHANNEL buttons simultaneously.

Note: These preset positions remain stored in the transmitter's memory until both the transmitter battery pack and the lithium back-up battery have been removed (or until data reset has been performed). Therefore, you do not have to reset the fail-safe each time you fly. Should you want to re-adjust the fail-safe presets, access the Fail-Safe Function and adjust the presets as you have just done. The transmitter automatically recalls the settings for the last fail-safe adjustment.

6.10 FAIL-SAFE/HOLD MEMORY IN S-PCM MODULATION (System Mode)

Hold Function (S-PCM)

The Hold Function is automatically activated when the radio is turned ON and in the S-PCM modulation.

This function stops (or holds) the servos in the positions they were in just prior to the interference.

Therefore, your aircraft maintains the position held immediately before the interference was experienced. When a clear signal is restored, the hold function releases, and control of the airplane returns to you.

Fail Safe/Hold Combination in S-PCM Modulation

The XP652 allows you to combine the hold and fail-safe presets for all six (6) channels on the receiver you can select fail-safe or hold independently for all channels on your aircraft. In other words, some channels will hold their last clear signal position, while others assume the preset position. Once the fail-safe has been activated by signal interruption (interference), the transmitter automatically moves the servos to a preset

position. The predetermined servo positions are set by you. In the S-PCM fail-safe, the time delay (the amount of time it takes, starting the moment the interference occurs, until the servos assume the preset positions) is fixed at .3, or 1/3, second.

After the interference has ceased, normal operation of the airplane returns to you immediately.



6.10 FAIL-SAFE/ HOLD MEMORY IN S-PCM MODULATION (continued)

Activating Servo Fail-Safe Pre-Sets by Channel (S-PCM)

1. Press the MODE and CHANNEL buttons simultaneously and hold.
2. Turn on the transmitter to enter the system mode.
3. Press the MODE button until FS1 appears on the screen. The #1 on the screen refers to the specific channel (1-6) to be adjusted.
4. Press the + or - button to activate (turn on) the preset position function for that channel.
5. Press the CHANNEL button to move to the next channel(s) to be adjusted (2-6). Repeat Step 4 for each channel to be activated.

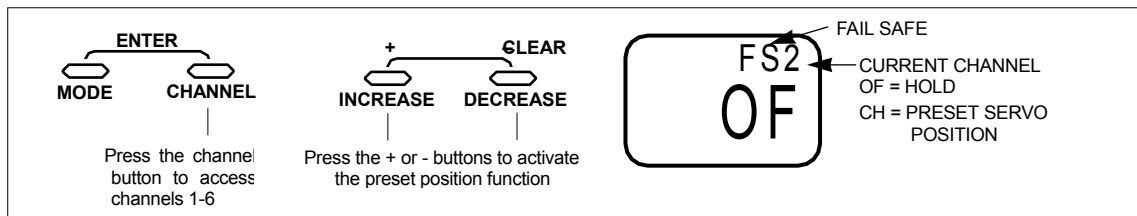

Note: If Hold Position (HO) is selected for all 6 channels, this Function/Screen will not be present.

Setting Servo Fail-Safe Presets in S-PCM Modulation

1. Press the Mode button until FSM appears on the screen.
 2. Set all controls to the desired Fail-Safe positions.
- Next press the + or - button simultaneously. A high pitch beep sound will confirm that the preset positions have been entered and accepted.

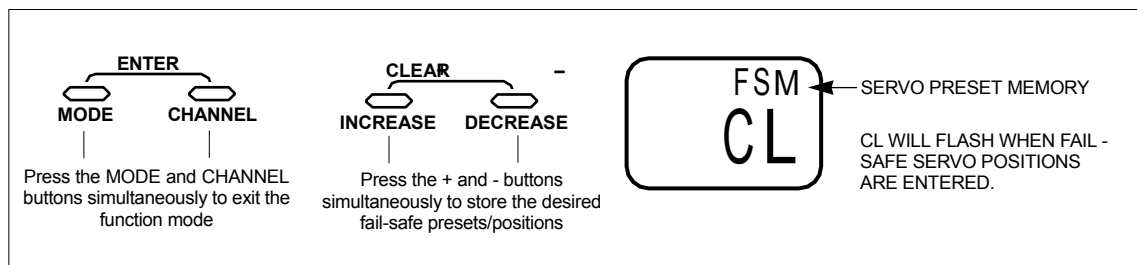

CHAPTER 7: FUNCTIONS • Helicopter (Function Mode)

7.1 SERVO REVERSING • Function Mode

Servo reversing is a very convenient function used in the setup of a new aircraft. It is used to change the direction of servo rotation in relation to the

corresponding stick movement. Servo reversing is available for all 6 channels.

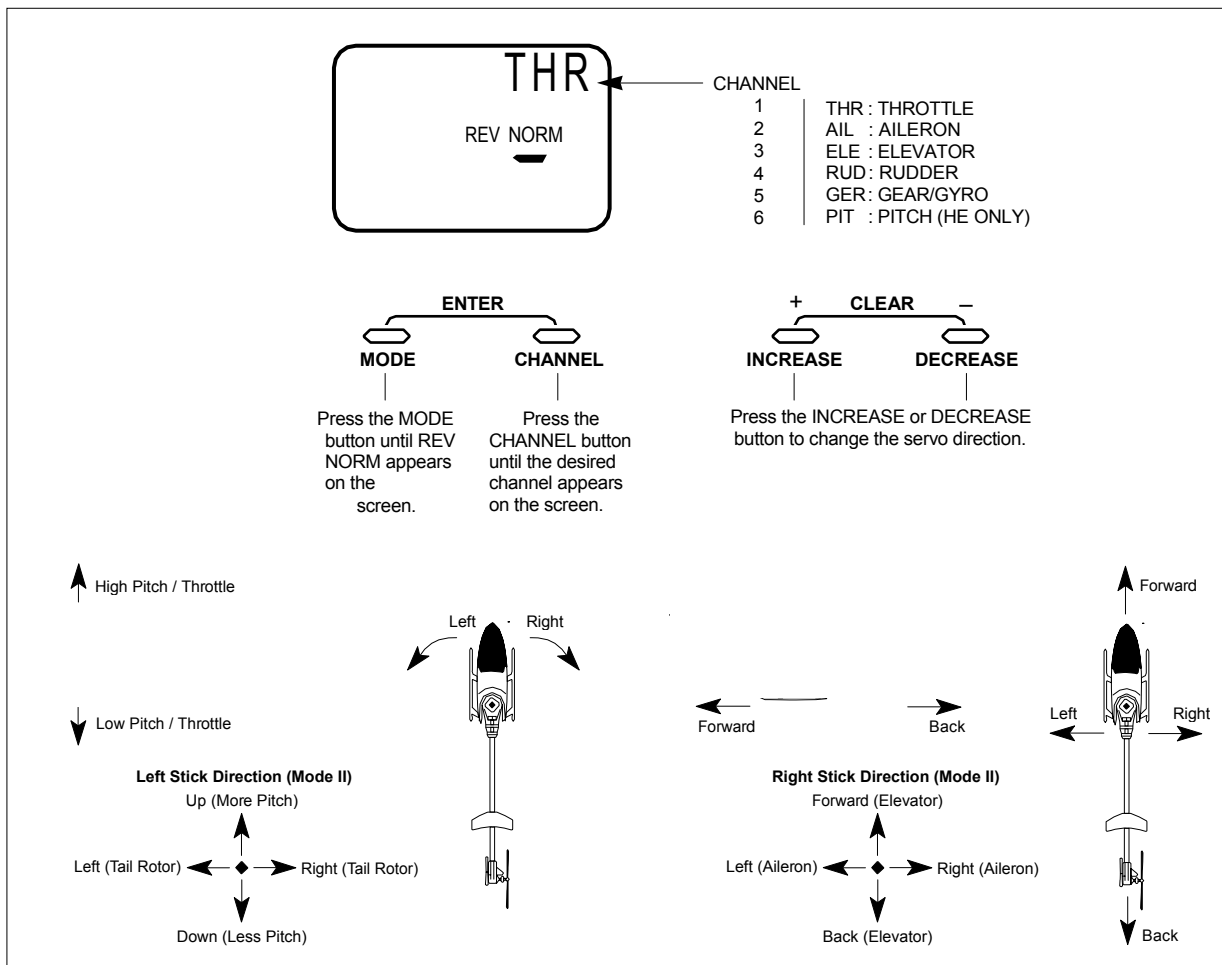

Accessing the Servo Reversing Function

1. Turn on the transmitter.
2. Press the MODE and CHANNEL buttons simultaneously to enter the function mode.
3. Press the MODE button until REV-NORM appears on the screen.
4. Press the CHANNEL button until the desired channel appears on the screen.
5. Press the INCREASE or DECREASE button to change the servo direction.
6. Press the MODE button to access the dual rate function.
7. To exit, press the MODE and CHANNEL buttons simultaneously.



7.2 DUAL RATE • Function Mode

Dual rate is available for the aileron and elevator channels. The purpose of this function is to allow for in-flight selection of two preset servo travels for each of these channels. The amount of travel is adjustable from 0-125%. The factory settings for both switch positions (0 and 1) is 100%. Either position may be selected as the low or high rate by placing the switches in the desired position and adjusting the value for that position. Operation of these switches is described in Section 6.3.

Different types of maneuvers require varying amounts of control movements. Snap rolls require large control movements, while smooth maneuvers like long slow rolls are best performed with smaller control movements. Dual rates allow you to change the control movements in flight at the flip of a switch. This allows you to execute maneuvers requiring both radical control movements and small control movements during a single flight.

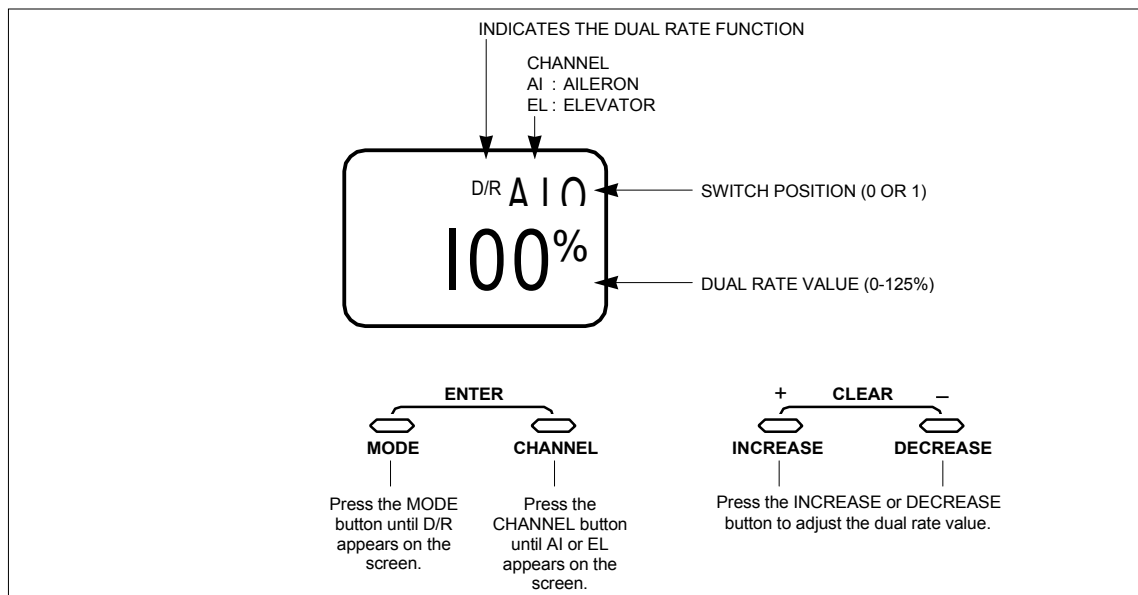

Accessing the Dual Rate Function

1. Turn on the transmitter.
2. Press the MODE and CHANNEL buttons simultaneously to enter the function mode.
3. Press the MODE button until D/R appears on the screen.
4. Press the CHANNEL button until the desired channel appears on the screen (AI = aileron or EL = elevator).
5. The number that appears directly to the right of the selected channel is the switch position. There are two switch positions, 0 and 1, for each of the channels. A 0 will appear when the selected dual rate switch is in the uppermost position and a 1 when the selected switch is in the lower position.
6. To change the switch selection you must enter the dual rate switch selection function in the system mode (see Section 6.3).
7. The number in the center of the screen indicates the current dual rate value for the selected switch position and channel. Press the INCREASE or DECREASE button to adjust the dual rate value (0 – 125%).
8. After adjusting the value for the 0 switch position, change to the 1 switch position and adjust the rates.
9. Press the CHANNEL button to select the other channel and adjust the dual rate value for both switch positions.
10. Press the MODE button to access the exponential rate feature.
11. To exit, press the MODE and CHANNEL buttons simultaneously.



7.3 EXPONENTIAL • Function Mode

Programmable exponential adjustments are offered on the aileron and elevator channels of your XP652 system. Exponential is a function that allows you to tailor the response rate of the controls as compared to the stick inputs. The purpose of exponential is to reduce the sensitivity in the middle portion of stick movement, while still allowing full travel at the end of the stick movement. In other words, the end result (travel) remains the same, although exponential changes the rate at which it achieves this travel.

The adjustable range of the Exponential Function is from 0–100%. Zero percent (0%) is linear stick control which means that the response rate is equal

throughout the stick control. One hundred percent (100%) is full exponential. The larger the exponential value, the less servo action, or sensitivity, you will notice around the neutral setting.

Note: The Exponential Function operates in conjunction with the Dual Rate Function. It is imperative to understand the Dual Rate Function prior to adjusting the exponential values.

Exponential may be selected independently for either the high or low rate (position 0 or 1), or both.

Note: The dual rate switch position is changed/ accessed by setting the appropriate dual rate switch to the 0 or 1 positions.

ENTER

MODE

Press the MODE button until EXP appears on the left side of the screen

CHANNEL

Press the CHANNEL button to select either aileron or elevator exponential

CLEAR

INCREASE

Press the + and - buttons to increase/decrease the exponential value (0 - 100%)

DECREASE

A GOOD STARTING POINT FOR EXPONENTIAL VALUE IS APPROXIMATELY 20% - 30%.

Accessing the Exponential Function

1. Turn on the transmitter.
2. Press the MODE and CHANNEL buttons simultaneously to enter the Function Mode.
3. Press the MODE button until EXP appears at the left side of the screen.
4. Press the CHANNEL button until the desired channel appears on the screen (AI or EL).
5. Using the appropriate dual rate switch, select the correct position to be adjusted (0 or 1).
6. Press the + or - buttons to increase/decrease the exponential value.
7. Press the MODE button to access the Sub-Trim Function.
8. To exit, press the MODE and CHANNEL buttons simultaneously.



7.4 SUB-TRIM • Function Mode

Sub-trim is an electronic trim that is available for each of the 6 channels. Sub-trim is particularly useful as it allows the mechanical trim levers to be returned to their neutral positions by adjusting /changing the servo's neutral position electronically, without the need to mechanically adjust the specific control linkage. This allows the same mechanical trim lever settings between the five models you can control

with this radio system. Sub-trim can also allow additional trim travel when mechanical trims do not provide enough movement.

Note: It is recommended to use as little subtrim as possible for adjustment. If more than 20-30 points are required, it is suggested that a mechanical linkage adjustment be performed.

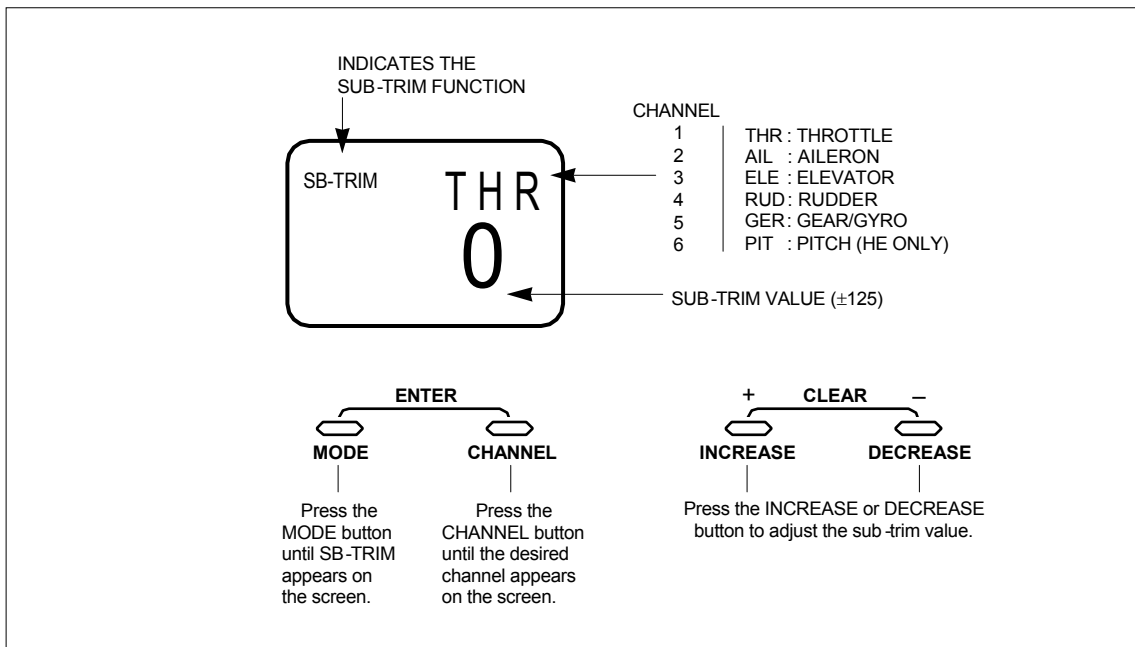

Accessing the Sub-Trim Function

1. Turn on the transmitter.
2. Press the MODE and CHANNEL buttons simultaneously to enter the function mode.
3. Press the MODE button until SB-Trim appears on the screen.
4. Press the CHANNEL button until the desired channel appears on the screen.
5. Press the INCREASE or DECREASE button to establish the desired amount of sub-trim.
6. Press the MODE button to access the TRAVEL ADJUSTMENT function.
7. To exit, press the MODE and CHANNEL buttons simultaneously.



7.5 TRAVEL ADJUSTMENT • Function Mode

The amount of servo travel is adjustable for each direction for each of the 6 channels individually. The adjustment range is from 0% to 150%. Travel adjustment is factory set at 100% for all channels.

The travel adjustment value displayed on the screen depends on the position of the stick or switch (e.g., flap switch, gear switch). This function is useful either to

maximize control surface travel, or to reduce travel to eliminate servo binding without the need for mechanical adjustment.

This function is also used to remove unwanted pitch-to-cyclic coupling when in CCPM Swashplate Mix mode. Please refer to page 84 of this manual for further information.

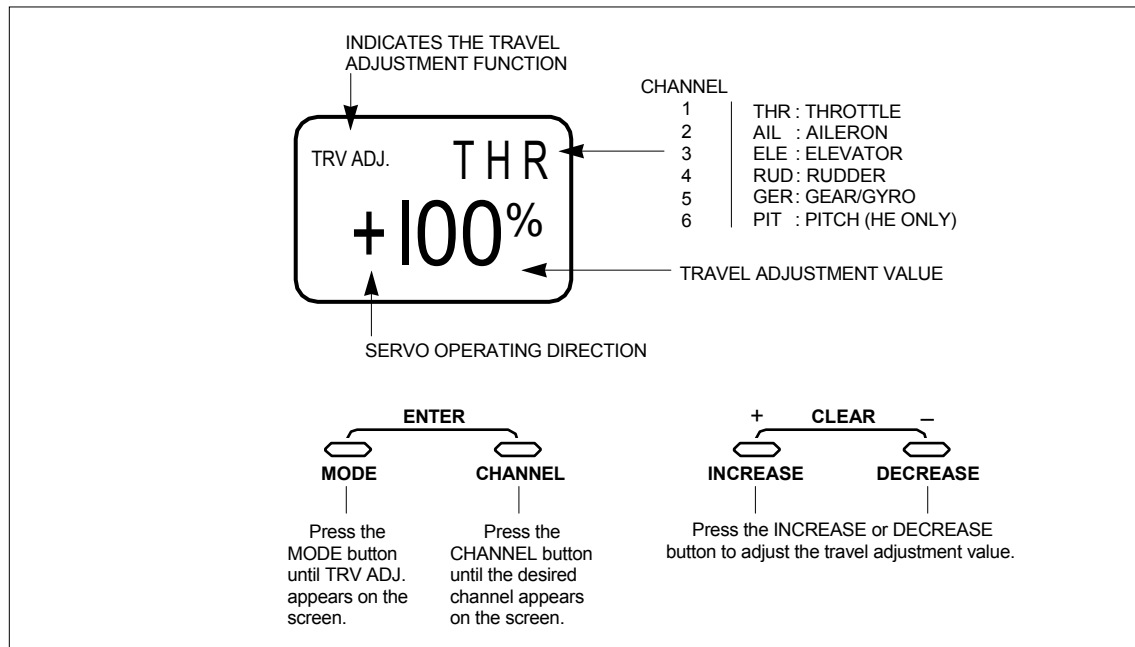

Accessing the Travel Adjustment Function

1. Turn on the transmitter.
2. Press the MODE and CHANNEL buttons simultaneously to enter the function mode.
3. Press the MODE button until TRV ADJ. appears on the screen.
4. Press the CHANNEL button until the desired channel appears on the screen.
5. Move the selected channel stick or switch in the direction that you want to adjust the travel. Press the INCREASE or DECREASE button to achieve the desired travel. Move the stick in the opposite direction to adjust the travel in the opposite direction.
6. The same may be done for all channels.
7. Press the MODE button to access the throttle hold function.
8. To exit, press the MODE and CHANNEL buttons simultaneously.



7.6 THROTTLE HOLD • Function Mode

The throttle hold function enables the throttle servo to be held in a specific location, while allowing the collective pitch servo to move independently with the throttle stick. The purpose of this function is for practicing autorotation landings with the helicopter's engine at idle. When the throttle

hold switch is changed from off to activated, there will be a third adjustable pitch curve added to the pitch curve function. The throttle hold switch is located on the top right rear corner of the transmitter. The throttle hold is on in the forward position. In the back position, the throttle hold function is off.

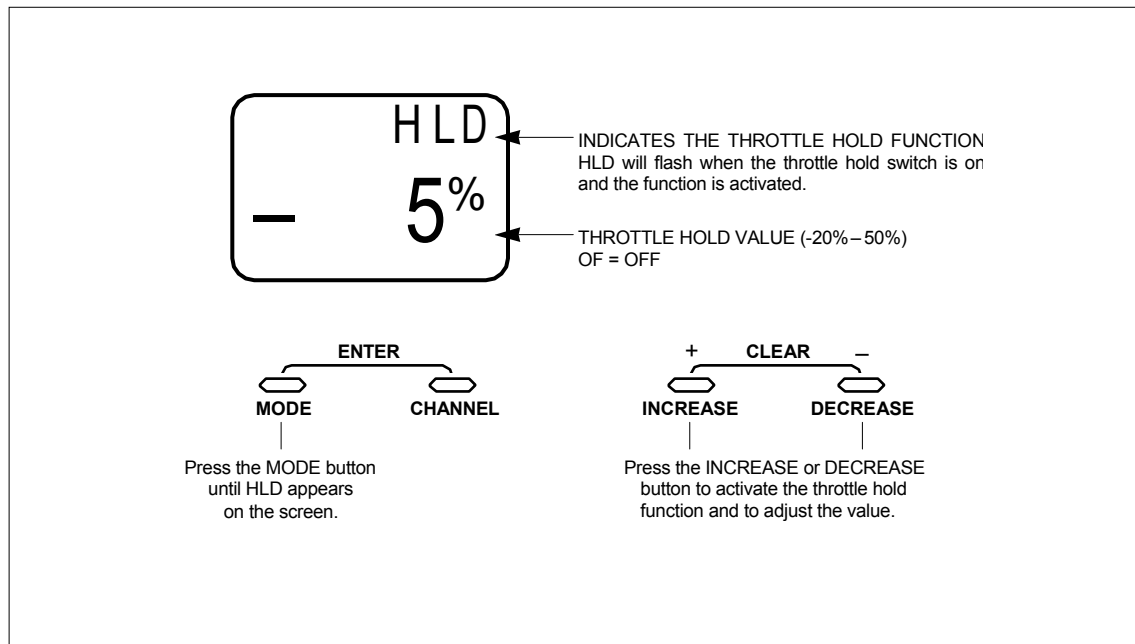

Accessing the Throttle Hold Function

1. Turn on the transmitter.
2. Press the MODE and CHANNEL buttons simultaneously to enter the function mode.
3. Press the MODE button until HLD appears on the screen.
4. The factory setting for the throttle hold function is off. (**Note:** When the throttle hold function is off, the throttle hold pitch curve will not appear in the pitch curve function). Press the INCREASE or DECREASE button to activate the throttle hold function. (The throttle hold pitch curve will now appear in the pitch curve function). To inhibit the throttle hold function, press the INCREASE and DECREASE buttons simultaneously.
5. Using the INCREASE or DECREASE button, adjust the throttle hold value to deliver a reliable engine idle speed. To do this, set the throttle trim to your normal starting idle setting (1/2, 3/4, etc.). Next, with the engine off, adjust your throttle hold value so that, when you change the throttle hold from on to off, there is no movement of the servo arm. The normal range of throttle hold is from -2 (1/2 trim) to +15 (full high trim).
6. Press the MODE button to access the pitch curve function.
7. To exit, press the MODE and CHANNEL buttons simultaneously.



7.7 PITCH CURVE • Function Mode

The XP652 offers 3 separate pitch curves with 3 adjustable reference points per curve. This function allocates a separate pitch curve setting during normal, stunt, and throttle hold modes to maximize flight performance. Once the pitch curves are established, each can be activated in flight using the 2-position flight mode switch and the throttle hold switch.

Each of the 3 reference points of the pitch curve are independently adjustable from 0–100%. These 3 points correspond to the low, middle, and high positions of the throttle stick (collective).

The graph below shows samples of pitch curves in the normal (N), stunt (S) and throttle hold (H) conditions. The factory preset values for all 3 pitch curves are: Low 0%, Middle 50%, and High 100%.

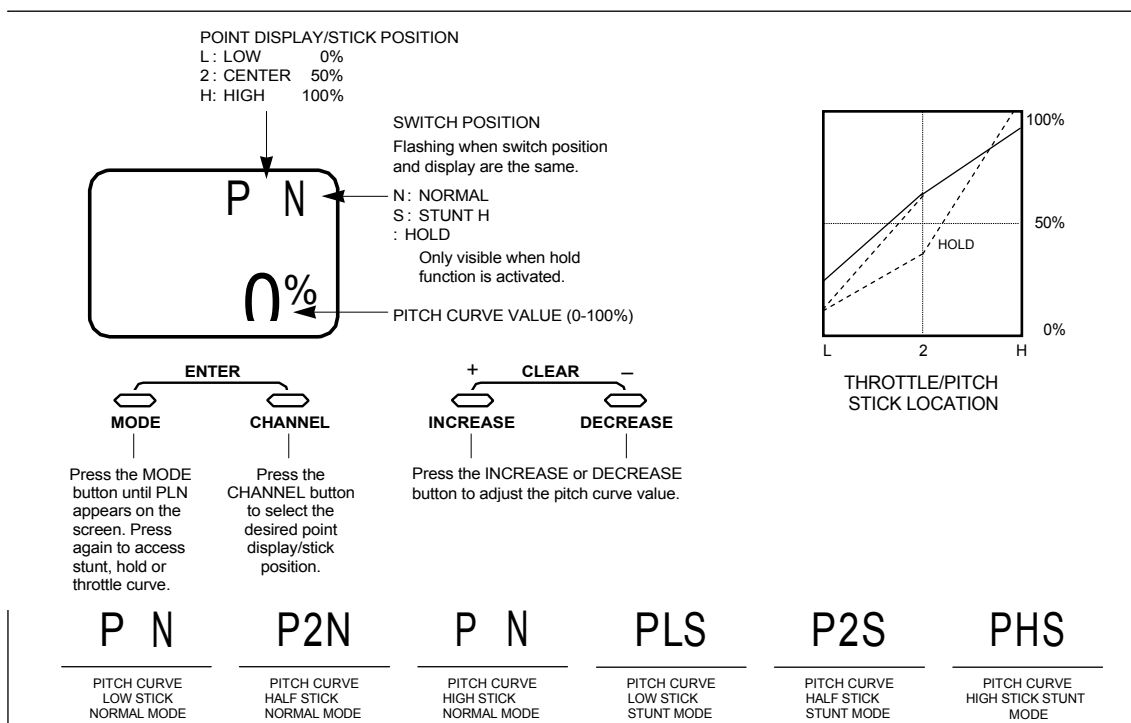

Accessing the Pitch Curve Function

1. Turn on the transmitter.
2. Press the MODE and CHANNEL buttons simultaneously to enter the function mode.
3. Press the MODE button until PLN appears on the screen. The letter to the far right indicates the specific pitch curve section that you are in (N, S or H). The letter in the center indicates the reference point that you are in (L, 2 or H).
4. Press the CHANNEL button to select the reference point of the pitch curve you want to change.
5. Press the INCREASE or DECREASE button to change the value of the current reference point. The range of each point is 0–100% in 1% intervals.
6. To set the pitch curve for the stunt (flight) mode, press the MODE button once. Then, repeat Steps 5 and 6 to adjust.
7. To set the pitch curve for the throttle hold mode, press the MODE button once. Then, repeat Steps 5 and 6 to adjust.
8. Press the mode button to access the throttle curve function.
Note: If throttle hold is not activated, the throttle curve function will be accessed.
9. To exit, press the MODE and CHANNEL buttons simultaneously.



7.8 THROTTLE CURVE • Function Mode

Adjustment of the throttle curve is very similar to the pitch curve adjustment described in the preceding section. A thorough understanding of the pitch curve section will make the throttle curve section easier to understand.

There are two independent types of throttle curves available — normal and stunt. The normal, or hover, throttle curve has 3 reference points (L, 2, H) and the stunt, or flight, throttle curve has 2 reference points (L, 2).

The two throttle curves are activated by the flight mode switch located on the top left rear corner of the transmitter. The throttle curve is in the normal condition when the flight mode switch is in the back position. The throttle curve is in the stunt condition when the flight mode switch is in the forward position.

Note: In stunt mode (S), the high position of the throttle curve is preset to 100%, and is not adjustable.

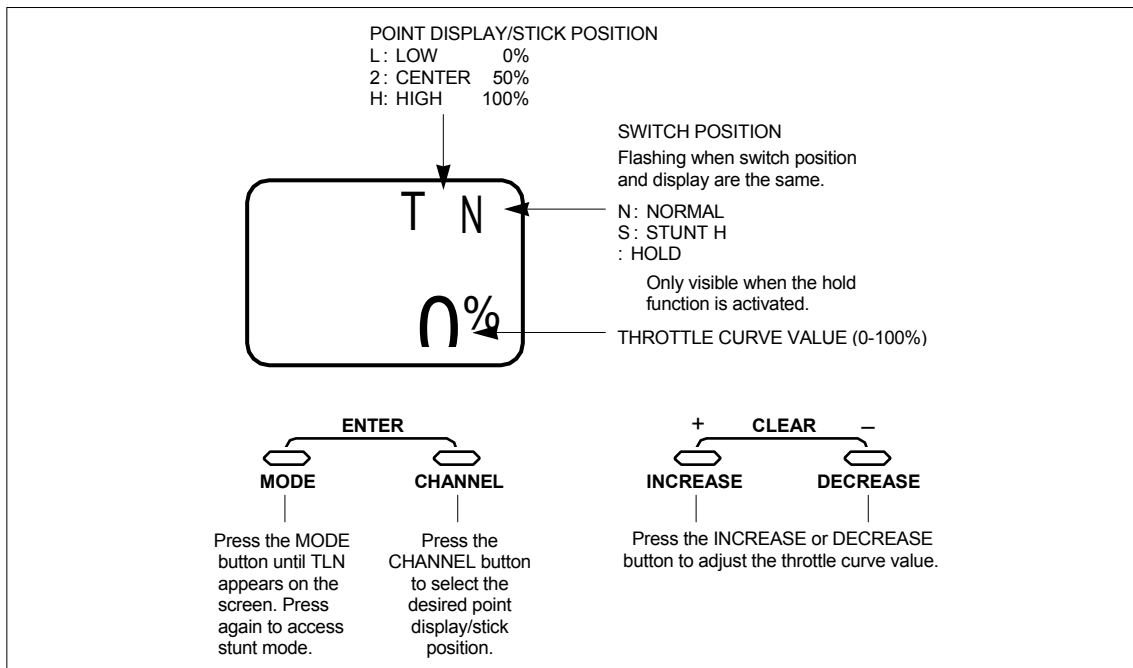

Accessing the Throttle Curve Function

1. Turn on the transmitter.
2. Press the MODE and CHANNEL buttons simultaneously to enter the function mode.
3. Press the MODE button until TLN appears on the screen. The letter to the far right indicates the specific throttle curve section that you are in (N, S or H). The letter in the center indicates the reference point that you are in.
4. Press the CHANNEL button to select the reference point of the throttle curve you want to change (L, 2 or H*).
5. Press the INCREASE or DECREASE button to change the value of the current reference point. The range of each point is 0–100% in 1% intervals.
6. To set the throttle curve for the stunt (flight) mode, press the MODE button once. Then, repeat Steps 5 and 6 to adjust.
7. Press the MODE button once to access the revolution mixing function.
8. To exit, press the MODE and CHANNEL buttons simultaneously.

* Normal mode only.



7.9 **REVOLUTION MIXING • Function Mode**

The revolution mixing function combines tail rotor input with the throttle/collective function to counteract the torque created by the main rotor blades. When properly adjusted, the helicopter will climb and descend without a tendency to yaw in either direction.

Since the torque created by the main rotor blades varies with different throttle/pitch settings, it is necessary for the tail rotor blades to change pitch at the same time. The “U” or up mixing adjusts the tail rotor compensation from the mid to high throttle stick setting. The “D” or down mixing adjusts the tail rotor compensation from the mid to the low throttle stick setting.

Thus, if you were to move the throttle from the low to

high positions, the tail rotor servo will move from the “D” to the “U” settings.

Revolution Mixing Set-up Procedure

First, set up the helicopter so that it will maintain a stable hover with the tail rotor trim in the center position. Next, bring the helicopter into a steady vertical climb. The body of the helicopter will move in the opposite direction to the main rotor rotation. Increase the “U” or up mixing until the helicopter climbs without the tendency to rotate. At a safe altitude, reduce the throttle. The helicopter will descend, and the body will turn in the same direction as the main rotor blades. Increase the “D” or down mixing until the helicopter descends without the tendency to rotate.

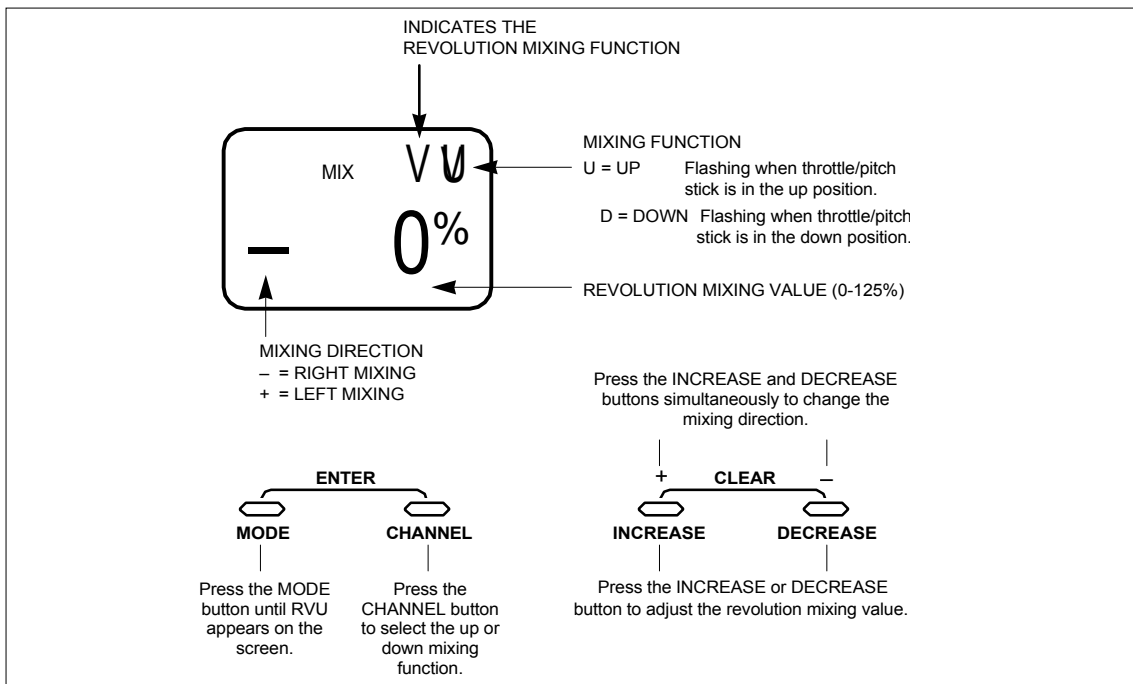

Accessing the Revolution Mixing Function

1. Turn on the transmitter.
2. Press the MODE and CHANNEL buttons simultaneously to enter the function mode.
3. Press the MODE button until RVU appears on the screen.
4. Press the CHANNEL button to select the up or down mixing function.
5. Press the INCREASE or DECREASE button to adjust the mixing value of the applicable function.

6. Press the INCREASE and DECREASE buttons simultaneously to reset the mixing value to 0%. To change the mixing direction, press the INCREASE and DECREASE buttons simultaneously again.
7. Press the MODE button to access the RUDDER OFFSET function.
8. To exit, press the MODE and CHANNEL buttons simultaneously.



7.10 RUDDER OFFSET • Function Mode

When the throttle hold switch is on (during autorotations), the revolution mixing feature becomes inactive. The rudder offset function is designed to automatically change the tail blade pitch when the throttle hold switch is on, providing a

straight descent during autorotations. The adjustable range of the rudder offset is L125 – 0 – R125. This feature is only applicable for helicopters using a “driven” or “limited slip” type tail rotor system during autorotations.

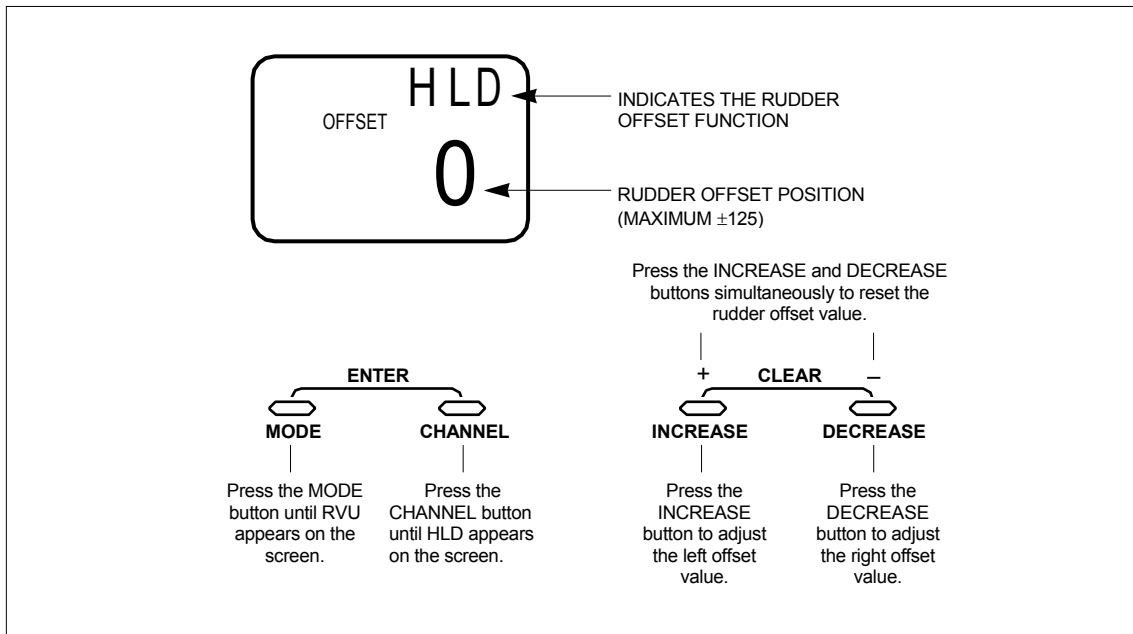

Accessing the Rudder Offset Function

1. Turn on the transmitter.
2. Press the MODE and CHANNEL buttons simultaneously to enter the function mode.
3. Press the MODE button until RVU appears on the screen.
4. Press the CHANNEL button until HLD appears on the screen.
5. From the 0 offset, press the DECREASE button to enter a right offset value or the INCREASE button to enter a left offset value. To reset the rudder offset value, press the INCREASE and DECREASE buttons simultaneously.
6. Press the MODE button to access the program mix A function.
7. To exit, press the MODE and CHANNEL buttons simultaneously.



7.11 PROGRAMMABLE MIXING (A) • Function Mode

The XP652 in helicopter mode offers one (1) programmable mix to be used for a number of different purposes. The functions allow mixing any one channel to any other channel.

The mix can remain ON at all times, or be switched OFF in flight using a number of different switches. (Refer to Chart A). Each channel is identified by channel numbers 1-6 (i.e., 2 = aileron, 4 = rudder, etc. — see Chart B) The channel appearing first is known as the “master channel,” or the channel to which you want to mix. The second channel is known as the “slave channel,” or the channel that is being mixed into the master channel. For example, ELEV-AILE

would indicate elevator to aileron mixing each time the elevator stick is moved, the elevator will deflect, and the aileron will automatically move in the direction and to the value input. Mixing is proportional, so small inputs of the master channel will produce small outputs of the slave channel. Each programmable mix has a mixing “offset.” The purpose of the mixing offset is to redefine the neutral position of the slave channel.

The Elevator-Aileron mix mentioned above is most commonly used to help trim the helicopter for proper “loop tracking.” This type of mix should be used only by pilots who are comfortable with their programming abilities with the XP652.

Chart A Switch Selection

SWITCH	MIX A
Always ON	ON
Flight Mode Switch Position 1 ON Flight	F1
Mode Switch Position O ON	FO
Throttle Hold Switch	H

Chart B Channel Numbers

CHANNEL NUMBER	FUNCTION
1	Throttle Aileron
2	Elevator Rudder
3	Gear Pitch (AUX1)
4	
5	
6	

Accessing the Programmable Mixing Function

1. Turn on the transmitter
2. Press the + and - buttons simultaneously to enter the Function Mode
3. Press the MODE button until MIX A11 appears at the top right corner of the screen. This is program mix A.

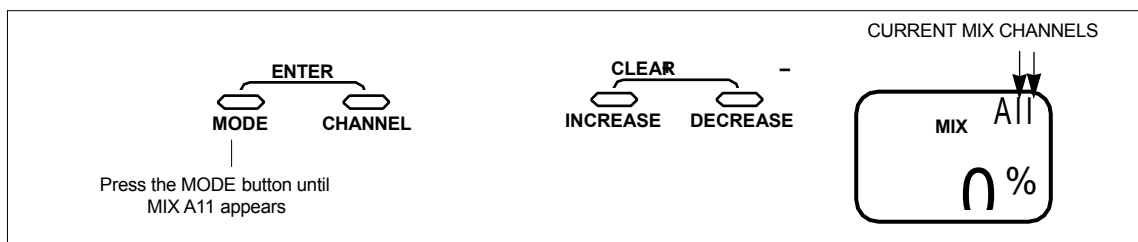

7.11 PROGRAMMABLE MIXING (A) • Function Mode (continued)

Assigning Channels

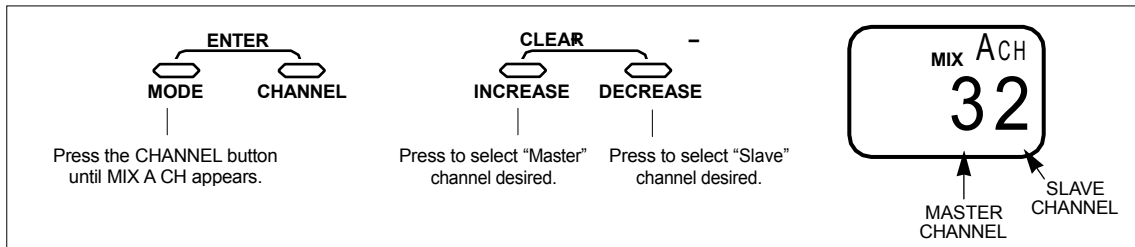

1. Press the CHANNEL button twice until MIX A CH appears on the screen.
2. Press the + button to select the desired "Master Channel" (1-6).
3. Press the - button to select the desired "slave channel" (1-6). Refer to Chart B on the preceding page for channel number clarification.

Switch Selection

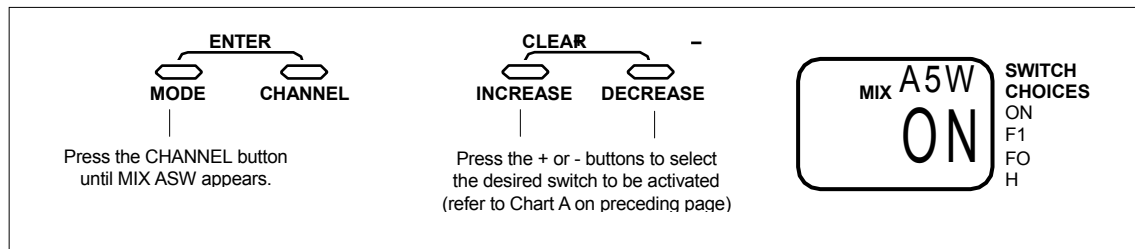

1. Press the Channel button once until MIX ASW appears.
2. Press the + or - button to select the desired switch to be used to activate the mixing, or leave as ON if a constant mix is desired. (Refer to Chart A on the preceding page for possible mix/switch selections.)



7.11 PROGRAMMABLE MIXING (A) • Function Mode (continued)

Mixing Value Adjustment

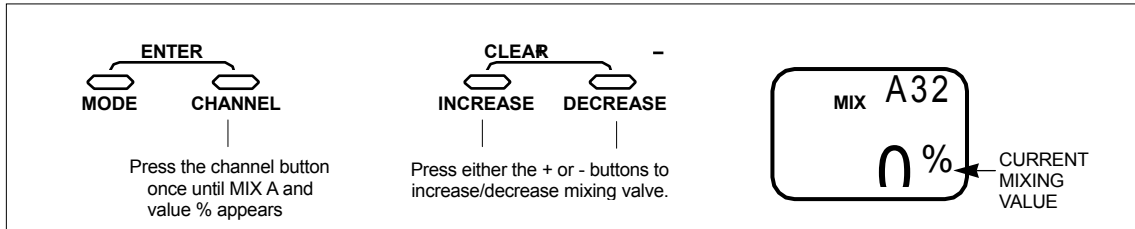

1. Press the CHANNEL button once until MIX A appears, with the mixing value located at the bottom of the screen.
2. To set the slave channels mixing valve, move and hold the master channel control stick to the direction to be adjusted (up/down — left/right), then press the + key to add + mixing value, or the - key to add - mixing value (+/-125%). When the

master channels stick is moved, the display will automatically show the mixing valve for the current stick direction.

Note: If a mix switch position other than ON is selected, it will be necessary to move the selected switch to the ON, or active, position to adjust the mixing value. OF will appear on the screen if the selected mixing switch is in the off position.

Mixing Offset Adjustment

The purpose of the mixing offset feature is to redefine the neutral position of the slave channel to be mixed. Any desired position may be selected for the offset reference point. To set the offset position, place the master channel's stick to the desired position and press either the + or - keys.

This position is now stored in the memory and its offset value from the neutral position of the master channel is indicated numerically on the LCD display. Then, the mixing value at the determined offset position is now set at 0.

Accessing the Offset Function

1. Press the CHANNEL button once until offset appears in the center of the screen.
 2. Place the master channel stick to the desired position of slave channel offset, then press either the + or - button to store.
 3. Press the MODE button once to access the stunt trim function.
 4. To exit the Function Mode, press the MODE and CHANNEL buttons simultaneously.
- Note:** If a mix switch position other than ON has been selected, it will be necessary to move the selected switch to the ON or active position to set the offset value. OF will appear on the screen if the selected mixing switch is in the OFF position.

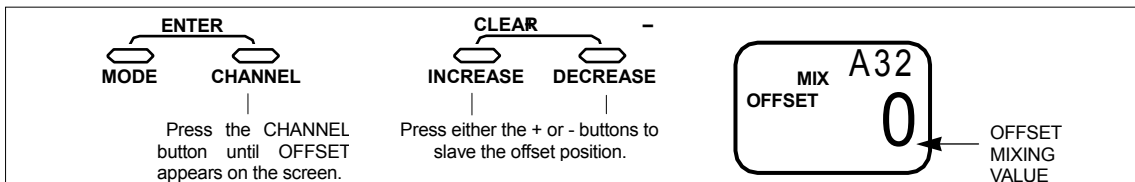

7.12 STUNT TRIM • Function Mode

The Stunt Trim Function is a trim position setting for aileron, elevator and rudder for use during forward flight maneuvers. This function is activated when in the Flight Mode 1 position only.

Center the elevator stick. Note which direction the helicopter pitches. If the helicopter pitches up, land the model and add down stunt trim. Repeat until no pitching occurs.

Note: When this function is activated, the trim levers of the aileron, elevator and rudder are inactive. The maximum adjustment range is approximately 30 degrees.

Next, check the rudder. Add rudder stunt trim until the tail tracks directly behind the helicopter. Finally, adjust the aileron stunt trim in the same manner until no rolling occurs. When properly adjusted, your helicopter will fly straight and level at full speed with no correction or trim required.

To adjust the stunt trim, fly your helicopter in a straight line at full throttle/pitch in Flight Mode 1.

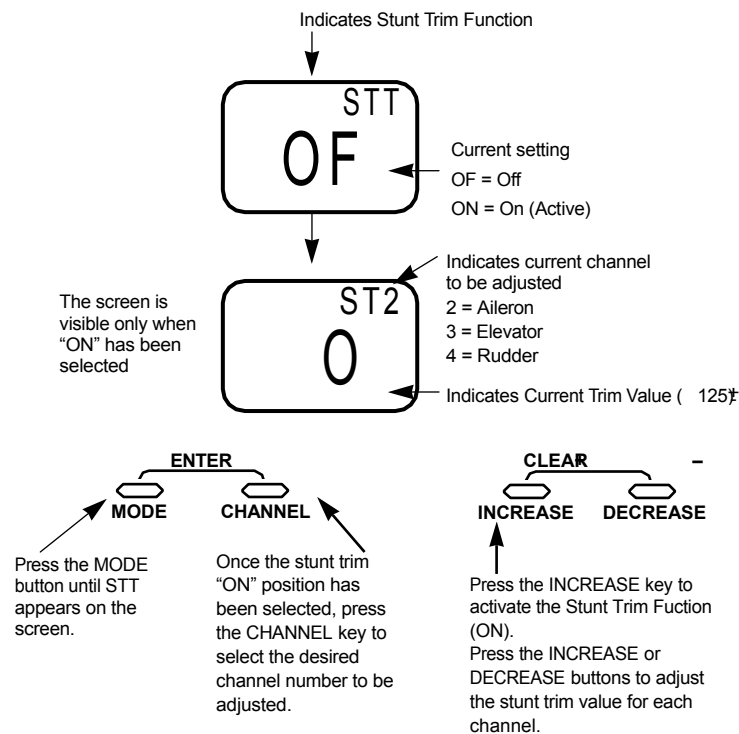

Accessing the Stunt Trim Function

1. Trim on the transmitter.
2. Press the MODE and CHANNEL buttons simultaneously to enter the Function Mode.
3. Press the MODE button until STT appears on the screen.
4. Press the increase button once to activate the Stunt Trim Function. "ST2" will appear on the screen, indicating that the stunt trim function is now "on."
5. Press the channel button to select the desired channel number to be adjusted.
6. Press the INCREASE or DECREASE buttons to select the desired trim value for each channel (125)†
7. Press the MODE button once to access the CCPM Swashplate Mix Function.
8. To exit, press the MODE and CHANNEL buttons simultaneously.



7.13 CCPM SWASHPLATE MIXING • Function Mode

The CCPM Swashplate Mixing Function (Cyclic Collective Pitch Mixing) of the XP652 system is designed to allow the XP652 to be used in model helicopters that utilize a 120° CCPM-type swashplate control system. CCPM is a type of pitch mixing where the three servos are connected directly to the

swashplate of the helicopter and physically move both in unison and independently for all changes in pitch/cyclic. Please refer to the diagram below for proper 120° three servo CCPM identification and connection.

3 Servos (120 degrees) CCPM Mixing

Note: The CCPM Swashplate Mixing Function is designed for use only with helicopters that incorporate the special 120° three servo CCPM control system design. Use of the CCPM Function in a non-CCPM-equipped model can result in an uncontrollable condition.

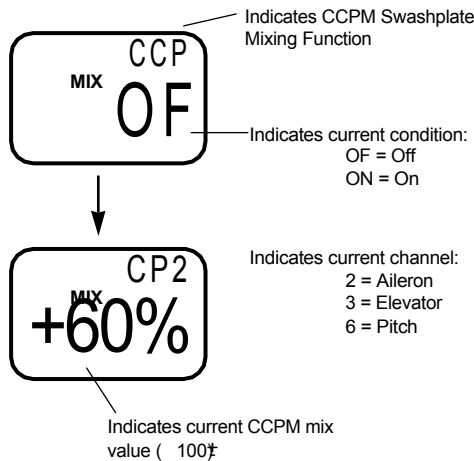
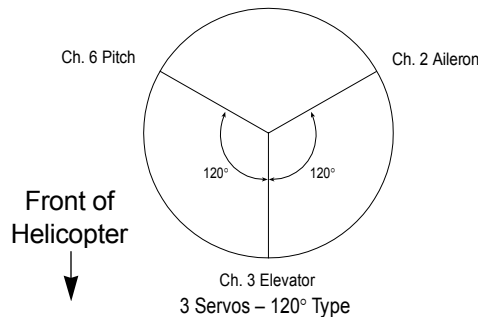

Please refer to the helicopter manufacturer's instructions for proper mixing values. Please also note that if control system interaction exists (pitch to aileron, pitch to elevator movement, etc.), it will be necessary to alter the travel adjust values for channels 2, 3, and 6 to correct this situation. Please refer to page 74 of this manual for further information.

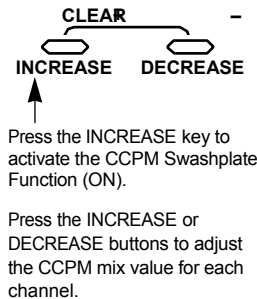
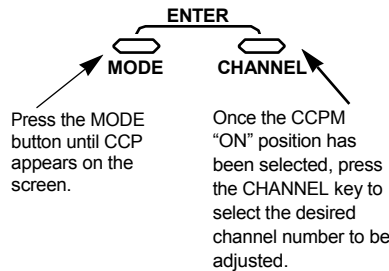

7.13 CCPM SWASHPLATE MIXING • Function Mode (continued)

Accessing the CCPM Swashplate Mixing Function

1. Turn on the transmitter
2. Press the MODE and CHANNEL buttons simultaneously to enter the Function Mode.
3. Press the MODE button until CCP appears on the screen.
4. Press the INCREASE button once to activate the CCPM Swashplate Mix Function. The screen will then move to the "CP2" screen, indicating that the CCPM function is now "on."
5. Press the CHANNEL button to select the desired channel number to be adjusted.
6. Press the INCREASE or DECREASE buttons to select the desired mixing value for each channel (100)±
7. Press the MODE button once to access the Trim Offset Value Function.
8. To exit, press the MODE and CHANNEL buttons simultaneously.



7.14 TRIM OFFSET MEMORY

The Trim Offset Memory Function of your XP652 allows you to test fly your aircraft and correct for any built-in trim requirements. After you adjust the aileron, elevator and/or rudder trim levers during the test flights, the trim levers are no longer in their center, or neutral, positions. The use of trim offset allows you to return the trims to their center, or neutral, positions without readjusting the control surface linkages mechanically.

This function is very useful when switching from model to model. It allows your trims to remain in their neutral positions while retaining their corrections. Using this feature, you can easily switch among the five (5) model memories without the need to readjust for each aircraft's individual trim requirements.

Note: In helicopter mode, the trim offset memory values stored will alter the servo position in both normal and stunt modes. Separate adjustments each mode is not possible, except through the stunt trim function (page 83).

Accessing the Trim Offset Memory Function

1. First, test fly your aircraft and adjust the aileron, elevator and/or rudder trim levers. After all adjustments have been made, land your helicopter. DO NOT adjust/reposition any of the trim levers at this time.
2. Turn on the transmitter.
3. Press the MODE and CHANNEL buttons simultaneously to enter the Function Mode.
4. Press the MODE button until TRM offset appears on the screen.

CAUTION: Do not attempt to adjust the Trim Offset Memory Function while your model's engine is running. Please stop your aircraft's engine before entering the Function Mode.

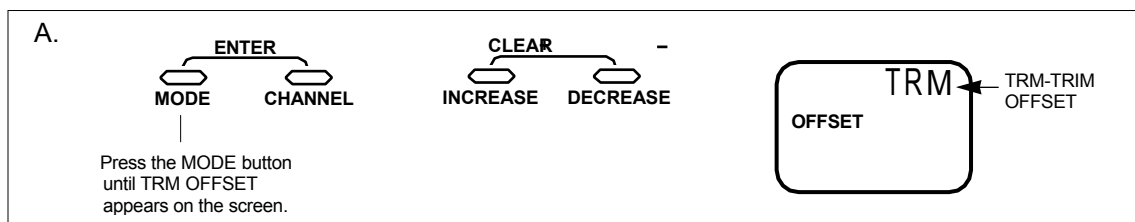

Accessing the Trim Offset Memory Function

5. Press the + or - buttons. MOV + CL should appear on the screen.

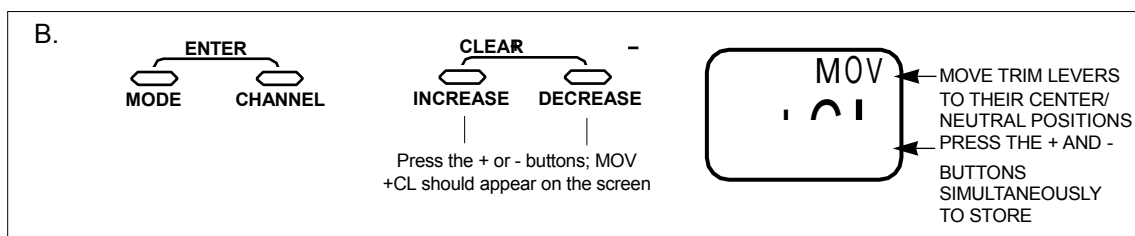

7.14 TRIM OFFSET MEMORY (continued)

Accessing the Trim Offset Memory Function (continued)

6. Move all trim levers to their center positions, then press the + or - keys simultaneously to store the trim offsets. The screen should appear as shown:
7. Press the MODE and CHANNEL buttons simultaneously to exit the function mode.

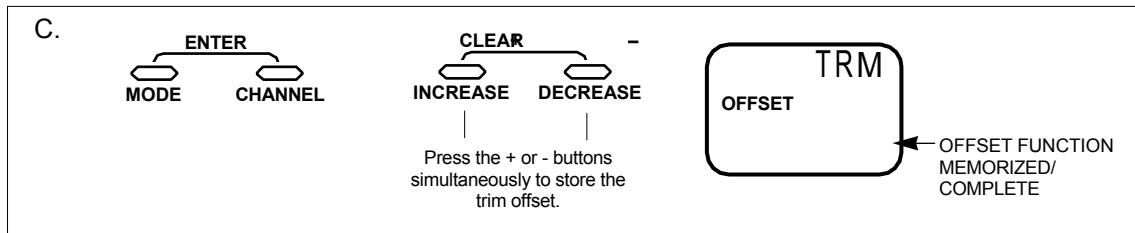

Over Trim

If OVR appears on the screen when the trim levers are moved to their center positions, this indicates that the amount of offset trim for one or more channels is in

excess of the acceptable limits. If this situation occurs, a mechanical adjustment of the control linkage will be necessary.

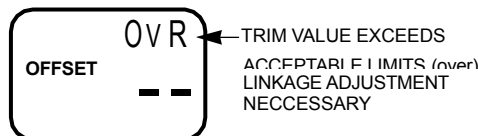

Clearing Trim Offset Memory

This feature is useful if you wish to clear all trim offset stored within the XP652's memory without affecting the data stored for other functions. The most common use for this feature is if you have disassembled/

repaired your model and would like to return all servos/trims to their "true neutral" positions before linkage installation/initial test flights.



7.14 TRIM OFFSET MEMORY (continued)

Accessing the Offset Trim Clear Function

1. Turn on the transmitter
2. Press the MODE and CHANNEL buttons simultaneously to enter the Function Mode.
3. Press the MODE button until TRM OFFSET appears on the screen.

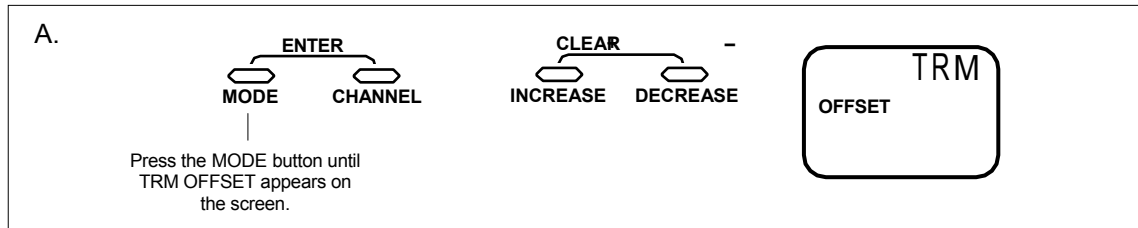

4. Press the CHANNEL button once; CL should appear at the bottom of the screen:

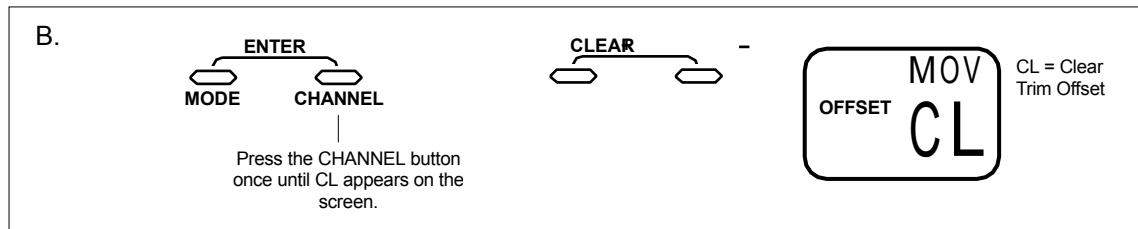

5. Press the + and - keys simultaneously .0 should appear on the screen indicating that the offset trim memory has been reset to 0, or neutral trim.
6. Press the MODE and CHANNEL buttons simultaneously to exit the function mode.

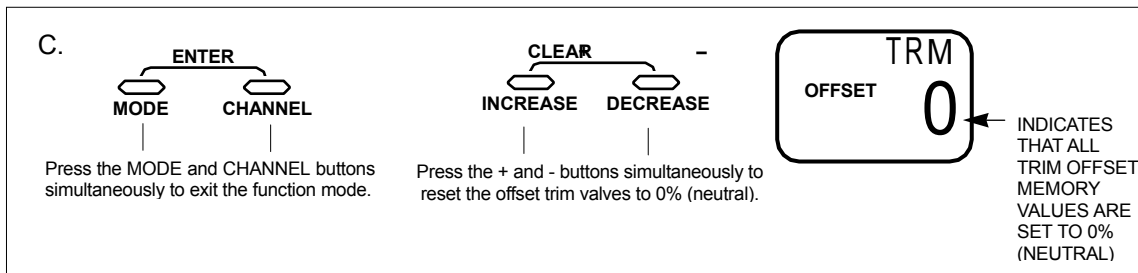

CHAPTER 8: DATA SHEETS • XP6452 Helicopter

8.1 ERGO .32/.46 (INITIAL SETUP)

Modulation S-PCM • Z-PCM • PPM (FM)

Model Number 1

Model Name E32

* Note: Before flying, confirm that all controls function in their proper direction.

CHANNEL	THR (1)	AIL (2)	ELE (3)	RUD (4)	GER (5)	PITCH (6)
* REVERSE SW	NORM • <input type="checkbox"/>	<input type="checkbox"/> NORM • REV	<input type="checkbox"/> NORM • REV	NORM • <input type="checkbox"/> REV	<input type="checkbox"/> NORM • REV	NORM • <input type="checkbox"/> REV
SUB-TRIM	Adjust so that no trim is required					
TRAVEL ADJUST (TRV ADJ.)	Adjust for full power	+ 80 %	+ 80 %	+ 100 %	+ 100 %	+ 150 %
	Adjust for engine off	- 80 %	- 80 %	- 100 %	- 100 %	-
FAIL-SAFE (S-PCM)	Adjust only if S-PCM modulation is selected					

FAIL-SAFE TIME (ZPCM)	Adjust only if Z-PCM modulation is selected
-----------------------	---

D/R SW	Factory Pre-Sets
--------	------------------

GEAR SW	Factory Pre-Sets
---------	------------------

THRO HOLD (HLD)	<input type="checkbox"/> ON <input type="checkbox"/> OFF	POSITION
		± Adjust for idle

REVO-MIX (RV)	+ UP (U)	35 %
	- DOWN (D)	35 %
HOLD RUDD OFFSET (OFFSET HLD)		±

STUNT TRIM			ON • OFF
AIL (2)	ELE (3)	RUD (4)	
+	+	+	
-	-	-	
Adjust Stunt Trim values as needed.			

			AIL (AI)	ELEV (EL)
DUAL RATE	POS 0	D/R	%	90 %
		EXP	%	20 %
EXP	POS 1	D/R	%	100 %
		EXP	%	20 %

		L	2	H
THRO CURVE TLN, T2N, THN,	N	0	50	100%
TLS, T2S	S	40	50%	
PITCH CURVE PLN, P2N, PHN,	N	-2° pitch	5° pitch	10° pitch
PLS, P2S, PHS,	S	-5° pitch	5° pitch	8.5° pitch
PLH, P2H, PHH	H	-5° pitch	5° pitch	13° pitch

		CHANNEL MASTER SLAVE	MIX SWITCH	OFFSET	+GAIN	-GAIN
PROG. MIX	A	→	ON • F1 • FO • H			

TRIM OFFSET	Store trim positions after initial test flight	CCPM MIXING		ON • OFF	
		AIL (2) + %	ELE (3) + %	Pitch (6) + %	
		-	-	-	-



CHAPTER 8: DATA SHEETS • XP652 Helicopter

8.2 ERGO .46 (INITIAL SETUP WITH 3D PITCH/THROTTLE CURVES)

Modulation S-PCM • Z-PCM • PPM (FM)

Model Number 2

Model Name E46

* Note: Before flying, confirm that all controls function in their proper direction.

CHANNEL	THR (1)	AIL (2)	ELE (3)	RUD (4)	GER (5)	PITCH (6)
* REVERSE SW	NORM • <input type="checkbox"/>	<input type="checkbox"/> NORM • REV	<input type="checkbox"/> NORM • REV	NORM • <input type="checkbox"/> REV	<input type="checkbox"/> NORM • REV	NORM • <input type="checkbox"/> REV
SUB-TRIM	Adjust so that no trim is required					
TRAVEL ADJUST	Adjust for full power	+ 80 %	+ 80 %	+ 100 %	+ 100 %	+ 150 %
(TRV ADJ.)	Adjust for engine off	- 80 %	- 80 %	- %	400	100 % -
FAIL-SAFE (S-PCM)	Adjust only if S-PCM modulation is selected					

FAIL-SAFE TIME (Z-PCM)	Adjust only if Z-PCM modulation is selected
------------------------	---

D/R SW	EA • A • E • <input type="checkbox"/> CF
--------	--

GEAR SW	Factory Pre-Sets
---------	------------------

THRO HOLD (HLD)	<input type="checkbox"/> ON	OF	POSITION
			± Adjust for idle

REVO-MIX (RV)	+	UP (U)	30 %
	-	DOWN (D)	30 %
HOLD RUDD OFFSET (OFFSET HLD)			±

STUNT TRIM		ON • OFF
AIL (2)	ELE (3)	RUD (4)
+	+	+
-	-	-
Adjust Stunt Trim values as needed.		

			AIL (AI)	ELEV (EL)
DUAL RATE	POS 0	D/R	90 %	90 %
		EXP	20 %	20 %
EXP	POS 1	D/R	100 %	100 %
		EXP	20 %	20 %

		L	2	H
THRO CURVE TLN, T2N, THN,	N	0	50	100%
TLS, T2S	** S	100	5%	/
PITCH CURVE PLN, P2N, PHN,	N	-2° pitch	5° pitch	10° pitch
PLS, P2S, PHS,	** S	-10° pitch	0° pitch	10° pitch
PLH, P2H, PHH	H	-5° pitch	5° pitch	13° pitch

CCPM MIXING		ON • OFF
AIL (2)	ELE (3)	Pitch (6)
+	+	+
-	-	%

		CHANNEL MASTER SLAVE	MIX SWITCH	OFFSET	+GAIN	-GAIN
PROG. MIX	A	→	ON • F1 • FO • H			

TRIM OFFSET	Store trim positions after initial test flight	** Note: Flight mode "S" (Stunt) shown is for 3D type flying only and is not recommended for use by entry level pilots.
-------------	--	---

CHAPTER 8: DATA SHEETS • XP652 Helicopter

8.3 ERGO .60 SPORT (INITIAL SET UP)

Modulation S-PCM • Z-PCM • PPM (FM)

Model Number 3

Model Name E60

* Note: Before flying, confirm that all controls function in their proper direction.

CHANNEL	THR (1)	AIL (2)	ELE (3)	RUD (4)	GER (5)	PITCH (6)
* REVERSE SW	NORM • <input type="checkbox"/>	<input type="checkbox"/> NORM • REV	<input type="checkbox"/> NORM • REV	NORM • <input type="checkbox"/> REV	<input type="checkbox"/> NORM • REV	NORM • <input type="checkbox"/> REV
SUB-TRIM	Adjust so that no trim is required					
TRAVEL ADJUST	Adjust for full power	+ 100 %	+ 100 %	+ 150 %	+ 100 %	+ 100 %
(TRV ADJ.)	Adjust for engine off	- 100 %	- 100 %	- 150 %	- 100 %	-
FAIL-SAFE (S-PCM)	Adjust only if S-PCM modulation is selected					

FAIL-SAFE TIME (ZPCM)	Adjust only if Z-PCM modulation is selected
-----------------------	---

D/R SW	Factory Pre-Sets
--------	------------------

GEAR SW	Factory Pre-Sets
---------	------------------

THRO HOLD (HLD)	<input type="checkbox"/> ON <input type="checkbox"/> OFF	POSITION
		± Adjust for idle

REVO-MIX (RV)	+	UP (U)	40 %
	-	DOWN (D)	20 %
HOLD RUDD OFFSET (OFFSET HLD)		±	

STUNT TRIM		ON • OFF
AIL (2)	ELE (3)	RUD (4)
+	+	+
-	-	-
Adjust Stunt Trim values as needed.		

			AIL (AI)	ELEV (EL)
DUAL RATE	POS 0	D/R	%	90 %
		EXP	%	25 %
EXP	POS 1	D/R	%	100 %
		EXP	%	30 %

		L	2	H
THRO CURVE	N	0	50	100%
TLN, T2N, THN, TLS, T2S	S	%	%	/
PITCH CURVE	N	-2° pitch	5° pitch	10° pitch
PLN, P2N, PHN, PLS, P2S, PHS,	S	-5° pitch	5° pitch	9° pitch
PLH, P2H, PHH	H	-5° pitch	5° pitch	13° pitch

CCPM MIXING		ON • OFF
AIL (2)	ELE (3)	Pitch (6)
+	+	+
-	-	%

	CHANNEL MASTER SLAVE	MIX SWITCH	OFFSET	+GAIN	-GAIN
PROG. MIX	A →	ON • F1 • FO • H			



TRIM OFFSET Store trim positions after initial test flight

CHAPTER 8: DATA SHEETS • XP652 Helicopter

8.4 DATA SHEETS

Modulation S-PCM • Z-PCM • PPM (FM)

Model Number _____

Model Name _____

CHANNEL	THR (1)	AIL (2)	ELE (3)	RUD (4)	GER (5)	PITCH (6)
* REVERSE SW	NORM •	NORM • REV	NORM • REV	NORM • REV	NORM • REV	NORM • REV
SUB-TRIM						
TRAVEL ADJUST	+ %	+ %	+ %	+ %	+ %	+ %
(TRV ADJ.)	- %	- %	- %	- %	- %	- %
FAIL-SAFE (S-PCM)						

FAIL-SAFE TIME (Z-PCM)	
------------------------	--

D/R SW	EA • A • E • CF
--------	-----------------

GEAR SW	F • H • A • E
---------	---------------

THRO HOLD (HLD)	ON OF	POSITION
		±

REVO-MIX (RV)	+	UP (U)	%
	-	DOWN (D)	%
HOLD RUDD OFFSET (OFFSET HLD)		±	

STUNT TRIM		ON • OFF
AIL (2) +	ELE (3) +	RUD (4) +
-	-	-
Adjust Stunt Trim values as needed.		

			AIL (AI)	ELEV (EL)
DUAL RATE	POS 0	D/R	%	%
		EXP	%	%
EXP	POS 1	D/R	%	%
		EXP	%	%

		L	2	H
THRO CURVE TLN, T2N, THN,	N	%	%	%
TLS, T2S	S	%	%	%
PITCH CURVE PLN, P2N, PHN,	N			
PLS, P2S, PHS,	S			
PLH, P2H, PHH	H			

CCPM MIXING		ON • OFF
AIL (2) +	ELE (3) +	Pitch (6) +
-	0%	

		CHANNEL MASTER SLAVE	MIX SWITCH	OFFSET	+GAIN	-GAIN
PROG. MIX	A	→	ON • F1 • FO • H			

TRIM OFFSET	
-------------	--



IMPORTANT INFORMATION

1

GENERAL NOTES

Radio controlled models are a great source of pleasure. Unfortunately, they can also pose a potential hazard if not maintained and operated properly. It is imperative that you install your radio control system correctly. Additionally, your level of piloting competency must be high enough to ensure that you are able to control your aircraft under all conditions. If you are a newcomer to radio controlled flying, please seek help from an experienced pilot or your local hobby shop.

Listed below are some safety Dos and Don'ts that must be followed by all pilots:

- Ensure that your batteries have been properly charged prior to initial flight.
- Keep track of the time that the system is turned on so that you will have an idea of how long you can safely operate your system.
- Perform a ground range check prior to the initial flight of the day. See the "Daily Flight Checks Section" below for information on how to do so.
- Check all control surfaces prior to each takeoff.
- Use frequency flags.
- Do not fly your model near spectators, parking areas, or at any other area that could result in injury to people or damage of property.
- Do not fly during adverse weather conditions. Poor visibility can cause disorientation and loss of control of your aircraft. Strong winds can cause similar problems.
- Do not fly unless your frequency is clear. **Warning:** Only one transmitter at a time can operate on a given frequency. If you turn on your transmitter while someone else is operating a model on your frequency, both pilots will lose control of their models. Only one person can use a given frequency at a time. It does not matter if it is AM, FM or PCM — **only one frequency at a time.**
- Do not point the transmitter antenna directly toward the model. The radiation pattern from the tip of the antenna is inherently low.
- Do not take chances. If at any time during flight you observe any erratic or abnormal operation, land immediately and do not resume flight until the cause of the problem has been ascertained and corrected.

2

DAILY FLIGHT CHECKS

1. Check the battery voltage on both the transmitter and the receiver battery packs. Do not fly below 9.0 volts on the transmitter or below 4.7 volts on the receiver. To do so can cause a crash of your aircraft.

Note: When you check these batteries, ensure that you have the polarities correct on your expanded scale voltmeter.

2. Check all hardware (linkages, screws, nuts, bolts) prior to each day's flight. Be sure that binding does not occur and that everything is properly secured.
3. Ensure that all surfaces are moving in the proper manner.
4. Perform a ground range check before each day's flying session. The range check should be as follows:
 - Do not extend the transmitter antenna at this time. Turn the transmitter "on."
 - Turn the model "on."
 - Slowly walk away from the model while moving the control surfaces. The aircraft should function properly at a distance of 75–100 feet.
5. Just prior to starting your aircraft, turn "off" your transmitter and then turn it back "on." Do this each time you start your aircraft. If any critical switches are on without your knowledge, the transmitter alarm will warn you at this time.
6. Ensure that all trim levers are in the proper location.
7. Check to be sure that all servo pigtails and switch harness plugs are secured in the receiver. Also, make sure that the switch harness moves completely in both directions.

14. WARRANTY AND SERVICE INFORMATION

3

WARRANTY COVERAGE

Your new equipment is warranted to the original purchaser against manufacturer defects in material and workmanship for one year from the date of purchase. During this period, Horizon Service Center will repair or replace, at our discretion, any component that is found to be factory defective at no cost to the purchaser. This warranty is limited to the original purchaser of the unit and is not transferable.

This warranty does not apply to any unit which has been improperly installed, mishandled, abused, or

damaged in a crash, or to any unit which has been repaired or altered by any unauthorized agencies. Under no circumstances will the buyer be entitled to consequential or incidental damages. This limited warranty gives you specific legal rights; you also have other rights which may vary from state to state. As with all fine electronic equipment, do not subject your unit to extreme temperatures, humidity or moisture. Do not leave it in direct sunlight for long periods of time.

4

REPAIR SERVICE INSTRUCTIONS

In the event that your equipment needs service, please follow the instructions listed below:

1. Check all on/off switches to be sure they are off. This will speed the repair process of checking battery condition.
2. Return your system components only (transmitter, receiver, servos, etc.). Do not return your system installed in a model car, boat, plane, etc.
3. Use the original carton/packaging (molded foam container), or equivalent, to ship your unit. Do not use the carton itself as a shipping carton; you should package the equipment carton within a sturdy shipping container using additional packing material to safeguard against damage during transit. **Include complete name and address information inside the carton, as well as clearly writing it on the outer label/return address area.** Ship your equipment fully insured and prepaid. Horizon Service Center is not responsible for any damages incurred during shipping.
4. Include detailed information explaining your operation of the equipment and problem(s) encountered. Provide an itemized list of equipment enclosed and identify any particular

area/function which may better assist our technicians in addressing your concerns. Date your correspondence and include your name, mailing address, and **a phone number where you can be reached during the business day.**

5. **Warranty Repairs.** To receive warranty service you must include a legible photocopy of your original dated sales receipt to verify your proof-of-purchase date. Providing that warranty conditions have been met, your radio will be repaired without charge.
6. **Normal Non-Warranty Repairs.** Should your repair cost exceed 50% of the retail purchase cost, you will be provided with an estimate advising you of your options.

Within your letter, advise us of the payment method you prefer to use. Horizon Service Center accepts VISA or MasterCard, please include your card number and expiration date.

Mail your system to:

Horizon Service Center
4105 Fieldstone Road
Champaign, Illinois 61822
(217) 355-9511
www.horizonhobby.com

FREQUENCY CHART

5

FREQUENCY CHART

72 MHz requires no special license to operate.

50/53 MHz requires the operator to have an FCC amateur radio license (Ham).

72 MHz		72 MHz		50MHz	
CH.NO.	FREQUENCY	CH.NO.	FREQUENCY	CH.NO.	FREQUENCY
15	72.090	36	72.510	00	50.800
16	72.110	37	72.530	01	50.820
17	72.130	38	72.550	02	50.840
18	72.150	39	72.570	03	50.860
19	72.170	40	72.590	04	50.880
20	72.190	41	72.610	05	50.900
21	72.210	42	72.630	06	50.920
22	72.230	43	72.650	07	50.940
23	72.250	44	72.670	08	50.960
24	72.270	45	72.690	09	50.980
25	72.290	46	72.710		
26	72.310	47	72.730		
27	72.330	48	72.750		
28	72.350	49	72.770		
29	72.370	50	72.790		
30	72.390	51	72.810		
31	72.410	52	72.830		
32	72.430	53	72.850		
33	72.450	54	72.870		
34	72.470	55	72.890		
35	72.490	56	72.910		
		57	72.930		
		58	72.950		
		59	72.970		
		60	72.990		

53 MHZ		
CH. NO.	FREQUENCY	FLAG COLOR
A1	53.100	Black/Brown
A2	53.200	Black/Red
A3	53.300	Black/Orange
A4	53.400	Black/Yellow
A5	53.500	Black/Green
A6	53.600	Black/Blue
A7	53.700	Black/Purple
A8	53.800	Black/Gray

***Channels 11–14 are not available**



