





8-3

MAIN ROTOR BLADE ATTACHMENT (BLADES NOT INCLUDED)

Two sets required

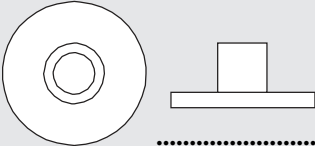
2 pcs
Socket Head Bolt, 4 x 35 mm	
2 pcs
Lock Nut, 4 mm	
4 pcs
Main Rotor Blade Spacers, 4 mm (12 mm Grip)	
2 pcs
Socket Head Bolt, 5 x 35 mm	
2 pcs
Lock Nut, 5 mm	

Hold the 4 mm Lock Nut while tightening using a Wiha 7 mm Nut Driver or equivalent.

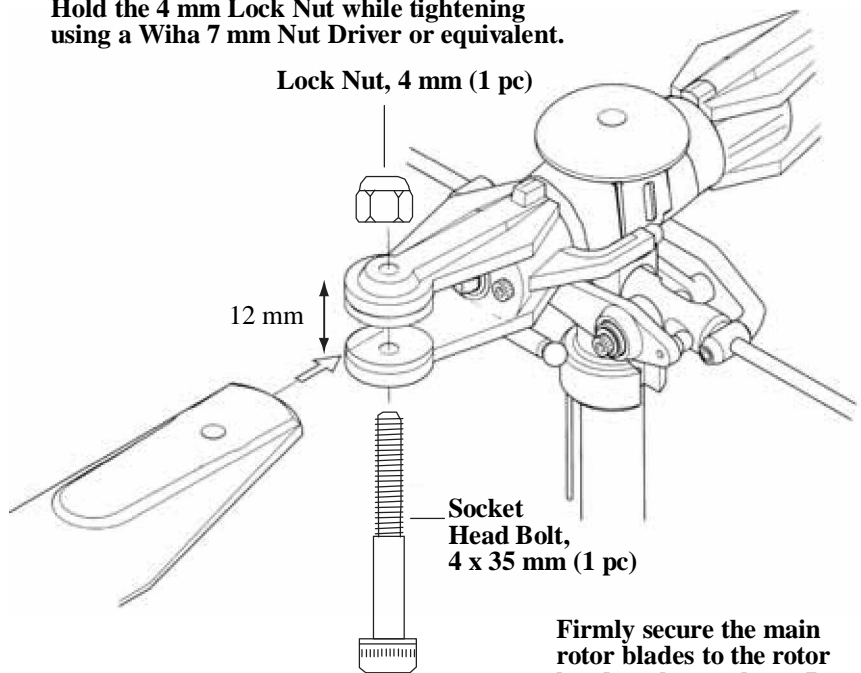

Firmly secure the main rotor blades to the rotor head as shown above. Be sure to note the proper direction of the rotor blades when assembling (clockwise rotation). Main blades should be tightened so they can pivot when moderate pressure is applied. Do not allow the main blades to swing freely within the main blade holders.

Note:

5 mm bolts are placed top down, 4 mm bolts are inserted bottom up.

Insert the main rotor blade spacers as shown.

Apply a light drop of CA adhesive to hold the main rotor blade spacers in place.

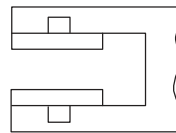

FINAL PREFLIGHT CHECK

Once all assemblies have been completed, please review the following suggestions before attempting initial flights.

- Review the instruction book and confirm that all assembly steps have been completed thoroughly.
- Check to insure that all servos are operating smoothly and in the correct direction. Also verify that there is no binding in the control rods and that each servo horn is secured with a servo horn mounting screw.
- Check to insure that all bolts and screws have been completely tightened and secured with threadlock where indicated.
- Verify that the gyro is operational and compensating in the correct direction (detailed in Section 7, page 61).
- Make sure that both the transmitter and receiver have been fully charged (refer to your radio system instructions for proper charging procedures).
- Check to insure that the throttle is working properly and in the correct direction.

BLADE TRACKING ADJUSTMENT

Blade “tracking” is an adjustment to the main rotor blade pitch that must be accomplished during the initial test flights.

Although the blade pitch angle in each blade may appear equal, it is still possible for a set of main rotor blades to run “out of track,” making adjustment necessary. Main rotor blades that are out of track with one another can cause vibration, instability, and a loss of power due to additional drag.

On the initial flight, it will be necessary to increase the blade speed to just before

lift-off rpm and view the rotor disc at eye level from a safe distance (approximately 15 to 20 feet).

Note which blade is running low (by colored tracking tape) and increase the pitch of the low blade one turn of the ball link at a time until each blade runs in track (on the same plane).

Please refer to the diagrams below to identify the different tracking situations, as well as several methods to mark each rotor blade for tracking identification.

BLADE TRACKING IDENTIFICATION

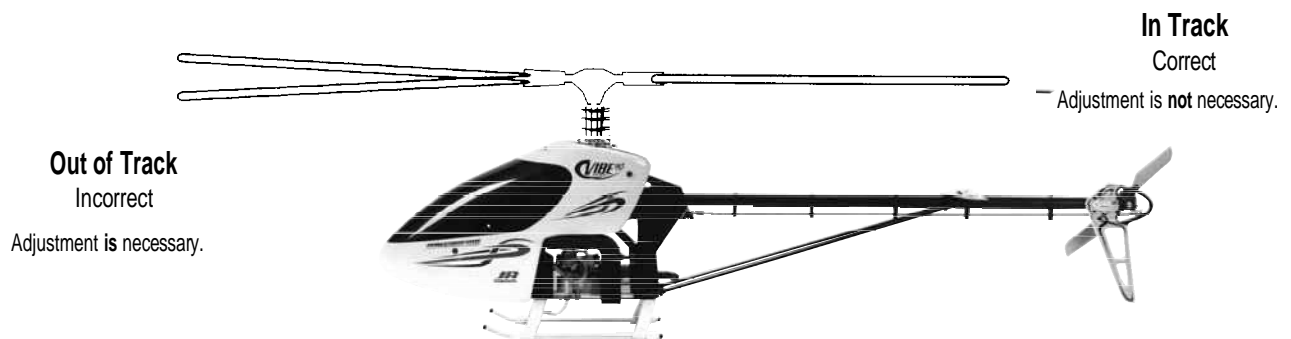

Caution: Be sure to maintain a safe distance from the helicopter (15 to 20 feet) when tracking main rotor blades.

Blade Labeling for Tracking Purposes

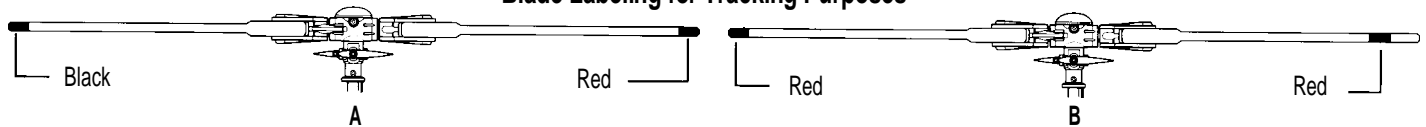

- A: Use two different blade tracking tape colors (e.g., black and red) at the tip of each main rotor blade.
- B: Use the same color blade tracking tape located at different positions on each rotor blade.

Note: Adding additional blade tracking tape to the rotor blades at this stage will make it necessary to re-static balance the main rotor blades.

GENERAL MAINTENANCE

Engine

After each day of flying, fully drain the fuel tank. Then start the engine and let it idle until the engine and the fuel line are completely burned off. It is also suggested that an after-run oil be used to prevent premature engine corrosion.

Check All Nuts and Bolts

A helicopter is subject to high vibration during flight. It is important to check that all screws, nuts and bolts are properly secured after each day of flying. It is also suggested that you perform a "quick" inspection between each initial test flight for approximately the first 6 to 10 flights.

Main Rotor Head

It will be necessary for the main rotor head dampers to be checked/and or replaced every 30–50 flights to maintain maximum rotor head performance. When replacing the main rotor head dampers, apply a light coating of oil to the dampers to prolong life.

It is also suggested at this time that the rotor head thrust bearings be lubricated using a high speed grease. This will prolong the visibility of the thrust bearings.

Tail Gear Case

The tail gear case should be repacked with grease every 50 or so flights. the tail pitch slider and mechanism should be oiled lightly every 5–10 flights to help reduce wear.

Washout Base

Lubricate the washout base using light oil every 10–15 flights to insure smooth operating and reduce wear. Inspect the washout base every 50–75 flights. If excess wear is noted, replace as needed.

Tail Pitch Slider

Lubricate the tail pitch slider using light oil every 5–10 flights to insure smooth operation and reduce wear.

Check Ball Link Wear

Check to insure that all universal links fit freely but securely to the control balls. If there is excessive play noted, adjust and or replace the universal link in question.

Battery Maintenance

Check to insure that your batteries are properly mounted and charged. The most frequent cause of crashes (aside from pilot error) is battery failure or disconnection. Be certain that your batteries are fully charged and limit your flight time to 3 or 4 flights between charging. If more flight time is required, purchase a reliable quick field charger.

Cleaning

At the end of each flight or flying session, wipe down your helicopter with a clean towel or rag. This is also a good time to inspect all parts for tightness or fatigue. Remember, a clean, well-maintained helicopter will provide you with many hours of trouble-free flight.

Ball Links

Check ball links every 15–20 flights for increased play and looseness. Adjust the ball links using pliers to tighten the ball race if needed.

P-1

ASSEMBLY PROCESS – MAIN ROTOR HEAD 1

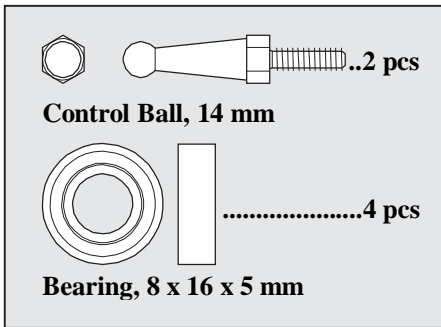

Use caution when inserting the main blade holder bearings so as not to distort/damage the main blade holders.
 Make two main blade holders.

TEAM TIP: JB Weld the bearings into the blade holders to reduce play in the blade holders.

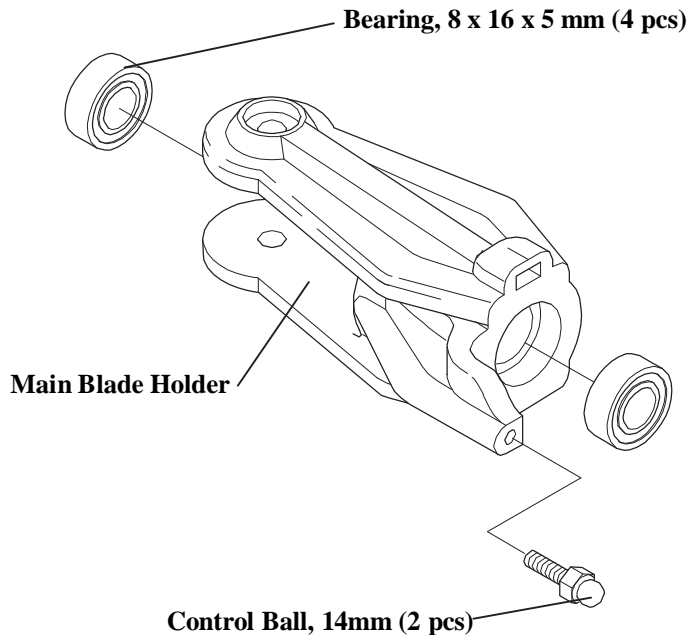

P-2

ASSEMBLY PROCESS – MAIN ROTOR HEAD 2

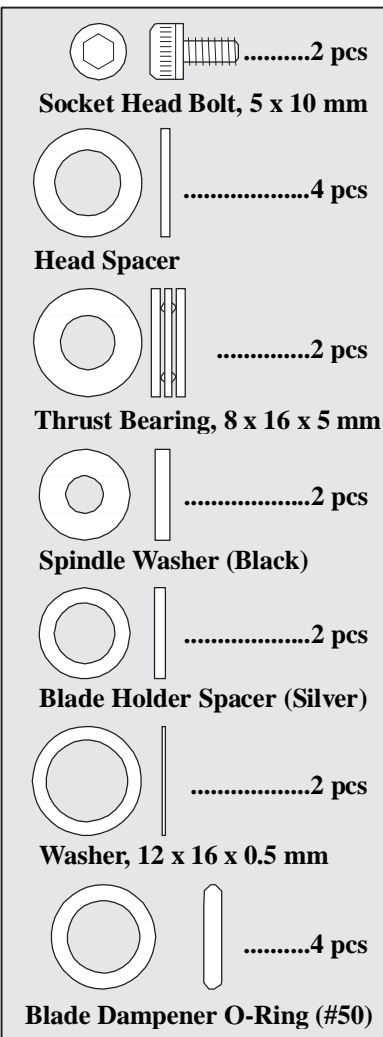

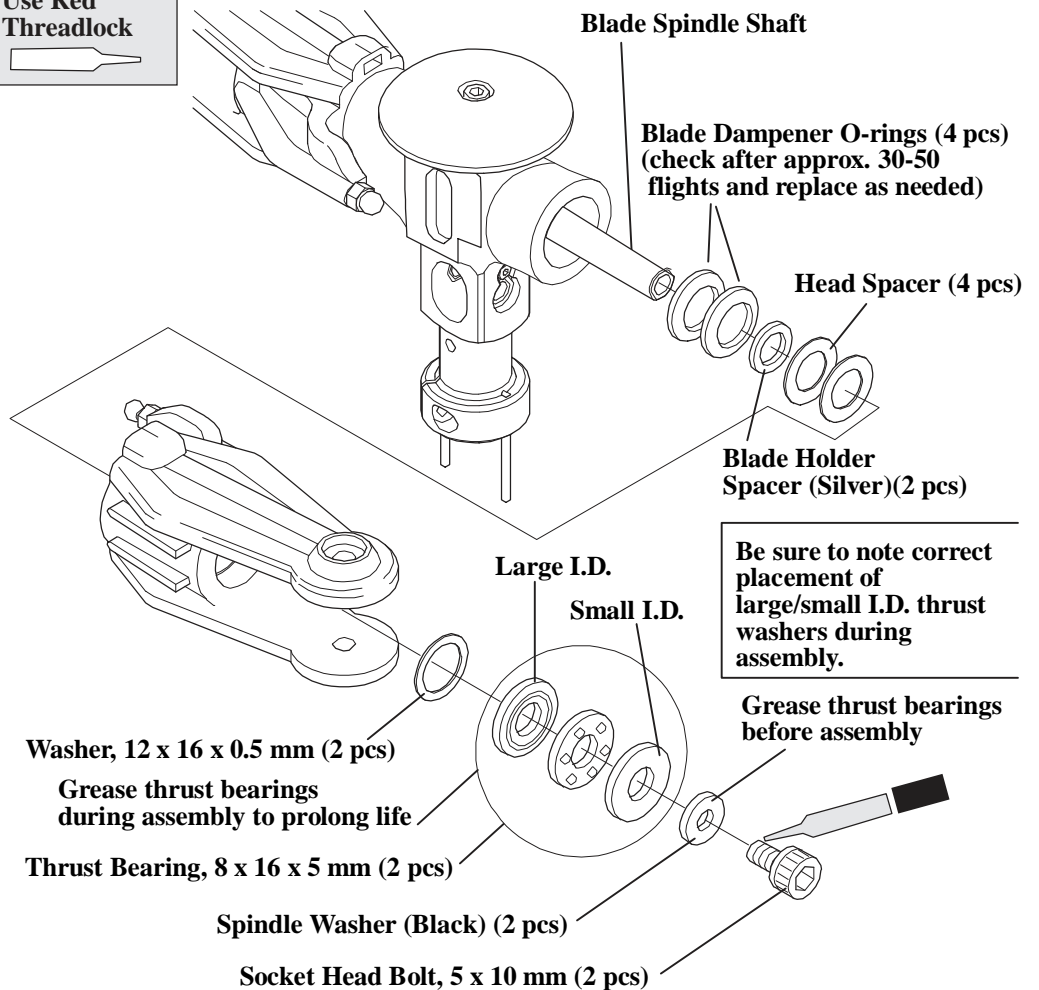

Use Red Threadlock



P-3

ASSEMBLY PROCESS PARTS – MAIN ROTOR HEAD 3





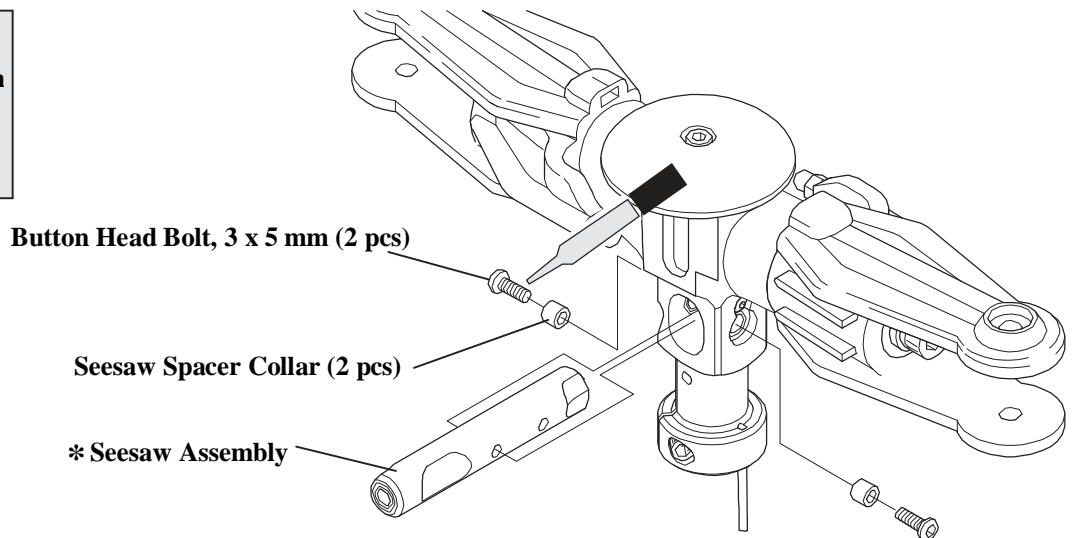

- 2 pcs
Button Head Bolt, 3 x 5 mm
- 2 pcs
Seesaw Spacer Collar

* Be sure to note correct placement of the front and the back of the seesaw assembly



P-4

ASSEMBLY PROCESS – MAIN ROTOR HEAD 4





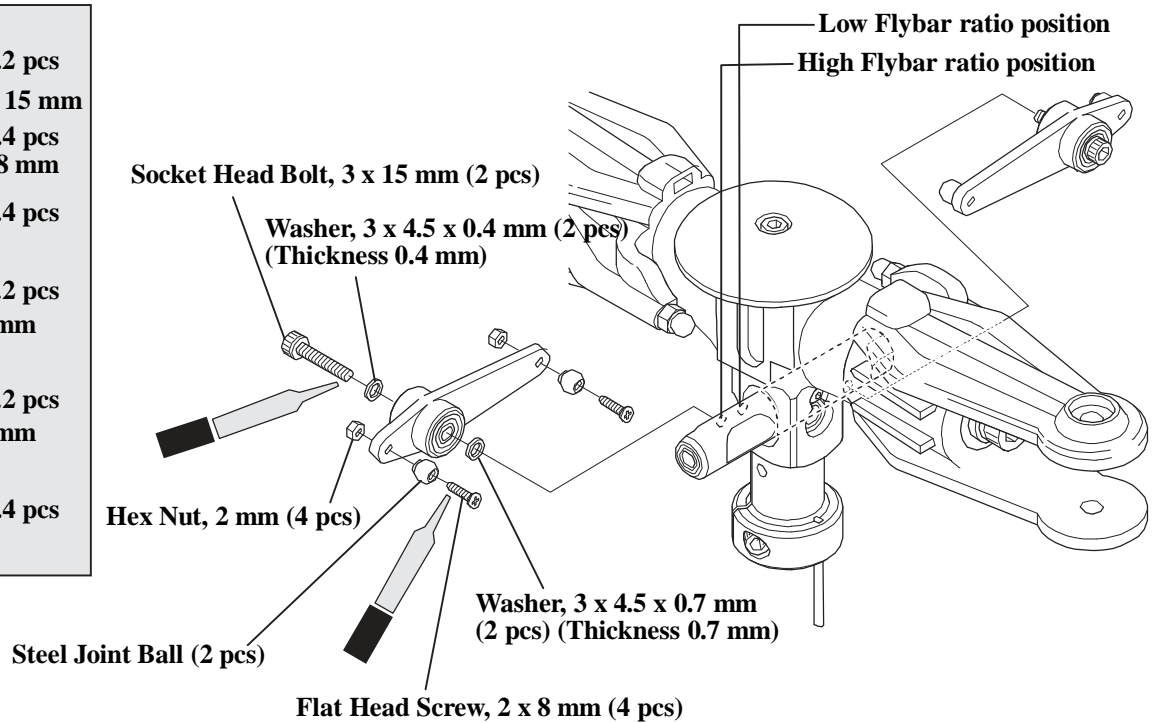







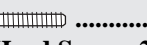

- 2 pcs
Socket Head Bolt, 3 x 15 mm
- 4 pcs
Flat Head Screw, 2 x 8 mm
- 4 pcs
Steel Joint Ball
- 2 pcs
Washer, 3 x 4.5 x 0.7 mm
(Thickness 0.7 mm)
- 2 pcs
Washer, 3 x 4.5 x 0.4 mm
(Thickness 0.4 mm)
- 4 pcs
Hex Nut, 2 mm

Use Red Threadlock

P-5

ASSEMBLY PROCESS – WASHOUT UNIT

	2 pcs
Socket Head Bolt, 3 x 15 mm		
	2 pcs
Flat Head Screw, 2 x 10 mm		
	4 pcs
Flange Bearing, 3 x 8 x 4 mm		
	2 pcs
Washout Link Pin		
	4 pcs
CA Stopper Ring, 2 mm		
	2 pcs
Washer, 3 x 4.5 x 0.4 mm		
	2 pcs
Spacer, 3 x 5 x 1.8 mm		
	2 pcs
Steel Joint Ball		



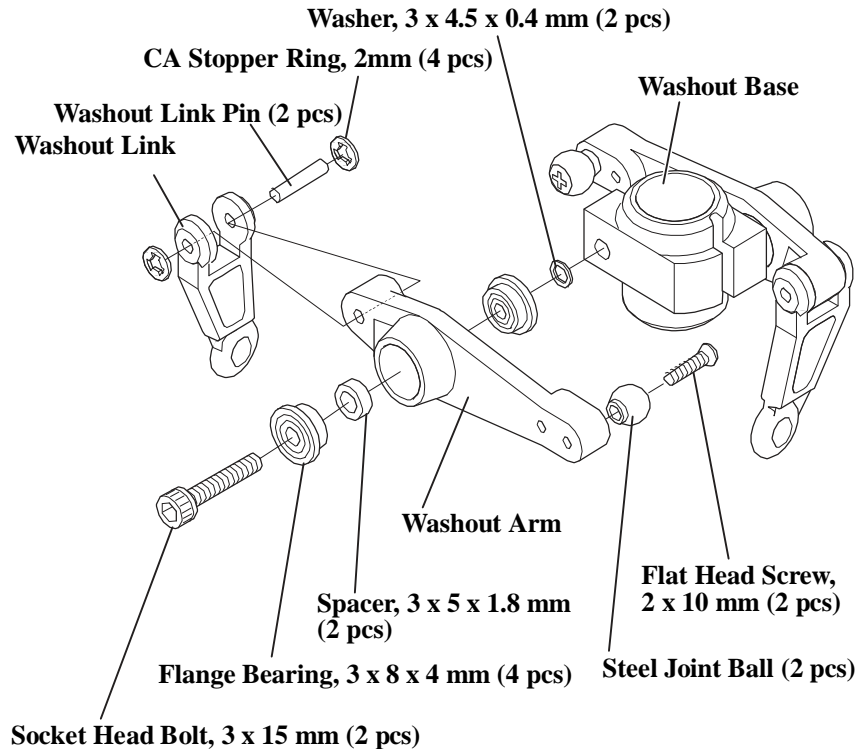

P-6

ASSEMBLY PROCESS – TAIL SLIDE RING

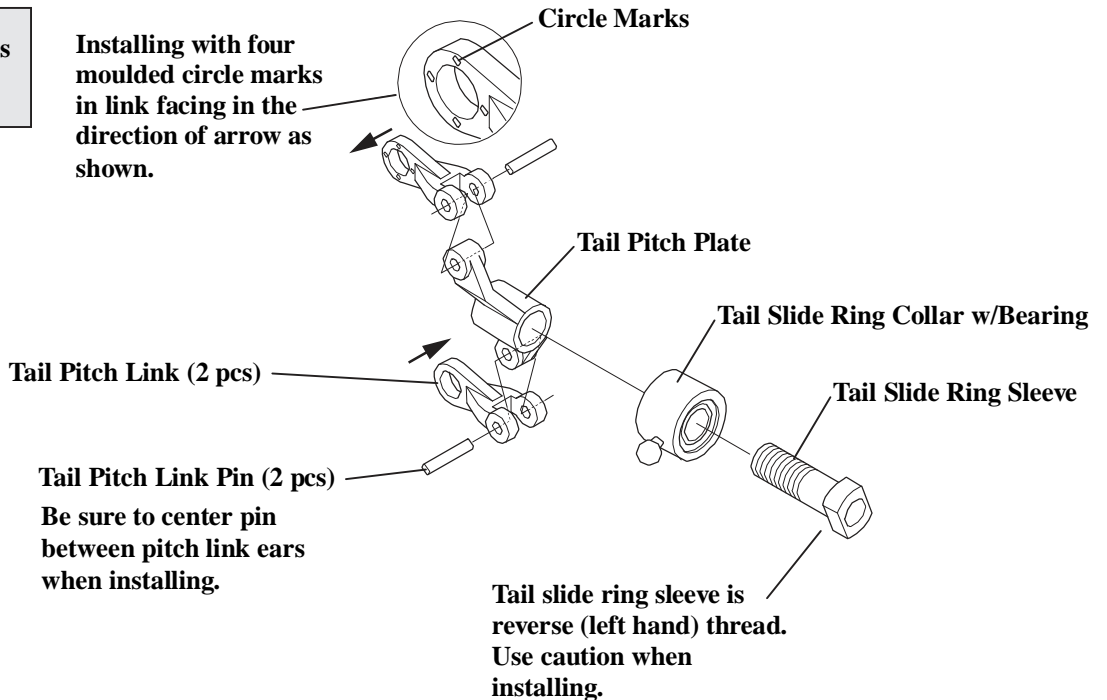

	2 pcs
Tail Pitch Link Pin		



- 2 pcs
Flat Head Screw, 2 x 8 mm
- 2 pcs
Steel Joint Ball

Make two flybar control arms.

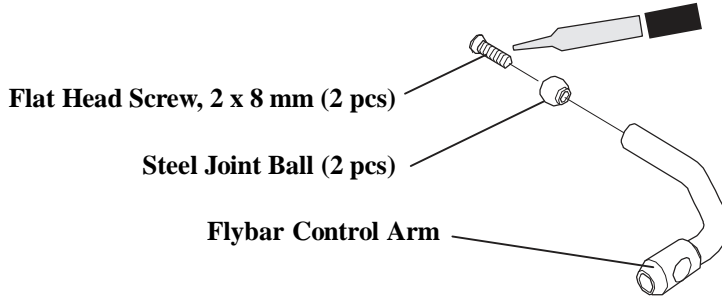
Use Red Threadlock



XP8103 Vibe 90 3D Data Sheet, 120° CCPM

MODEL NO. _____
 MODEL NAME _____

VIBE 90 3D

MODULATION SPCM - ZPCM - PPM _____

DUAL-RATE • EXP	0	D/R	AILE	ELEV	RUDD
		EXP	100%	100%	100%
	1	D/R	25%	25%	25%
		EXP	100%	100%	100%
		EXP	0%	0%	+65%

AUTO D/R (POS. 1)	ST1	INH • ACT
	ST2	INH • ACT
	HOLD	INH • ACT
	AUX2	HOLD SW • PIT.TRIM • INH
INPUT SEL	GEAR	ACT • INH

	THRO	AILE	ELEV	RUDD	GEAR	PIT	AUX2	AUX3
REVERSE SW	NORM ○	NORM • REV	NORM • REV	NORM • REV	NORM • REV	NORM • REV	NORM • REV	NORM • REV
SUB-TRIM	ADJUST SO THAT NO TRIM IS REQUIRED							
TRAVEL ADJUST	H 150%	L 115%	D 115%	L 150%	+ 100%	H 115%	+ 150%	+ 150%
	L 150%	R 115%	U 115%	R 150%	- 100%	L 115%	- 150%	- 150%
FAIL SAFE (SPCM)	SET TO DESIRED SETTINGS							

Throttle travel must be set to 150% if program mixing is to be used.

	EXP	L	1	2	3	H	
THRITTLE CURVE	N	OFF ON	0%	38%	56%	74%	100%
	1	OFF ON	100%	75%	55%	75%	100%
	2	OFF ON	100%	75%	55%	75%	100%
PITCH CURVE	N	OFF ON	0°	25%	47%	80%	95%
	1	OFF ON	0°	25%	50%	75%	95%
	2	OFF ON	0°	25%	50%	75%	95%
	H	OFF ON	0°		50%		100%

GYRO SENS	INH • RUDD/R ○ AUTO	0	Set gain	
		1	per Gyro's instruction settings.	
			NORM	0
			STNT	1
			HOLD	0
		INVT		
SWASH MIX		AILE	+50%	
3 SERVO		ELEV	+50%	
120°		PIT	+60%	
EXPACT				

THRO HOLD	INH • ACT	POS
		Set for Idle

TRIM STEP	SYSTEM	MODE
AILE	2	
ELEV	2	
RUDD	1	

PROGRAM MIX	MIX1	CHANNEL AILE→THRO	SW ON	EXP OFF ON	L 20	1 -	2 0	3 -	H 20	SW F-S12
	MIX2	ELEV→THRO	ON	OFF ON	20	-	0	-	20	F-S12
					+POS		-POS		OFFSET	
	MIX3	ELEV→AILE			+14%		+14%		0	F-S12

XP9303 Vibe 90 3D Data Sheet, 120° CCPM

MODEL NO. _____

MODEL NAME _____

VIBE 90 3D

	THRO	AIL	ELEV	RUDD	GEAR	PITCH	AUX2	AUX3
REVERSE SW	<input type="radio"/> NORM <input type="radio"/> REV	<input type="radio"/> NORM <input type="radio"/> REV	<input type="radio"/> NORM <input type="radio"/> REV	<input type="radio"/> NORM <input type="radio"/> REV	<input type="radio"/> NORM <input type="radio"/> REV	<input type="radio"/> NORM <input type="radio"/> REV	<input type="radio"/> NORM <input type="radio"/> REV	<input type="radio"/> NORM <input type="radio"/> REV
SUB TRIM	Adjust so that no Sub Trim is needed							
TRAVEL ADJUST	+ 100% - 100%	L 115% R 115%	U 115% D 115%	L 150% R 150%	L 100% R 100%	U 115% D 115%	+100% - 100%	+100% - 100%
FAIL-SAFE (SPCM)	Set to desired settings							

DUAL RATE/EXP	0	D/R	100%	100%	100%
		EXP D/R	25%	25%	25%
	1	EXP	100%	100%	100%
			30%	30%	30%

AUTO D/R	POS0	<input type="radio"/> ACT	INH
	POS1	<input type="radio"/> ACT	INH
	POS2	<input type="radio"/> ACT	INH

INPUT SEL	AUX2	HOLD PIT	INH
	AUX3	ACT	INH
	GEAR	ACT	INH

THRO CURVE	EXP	0	1	2	3	4	5	6	
	N	ON/OFF	0	—	56	—	68	74	100
	1	ON/OFF	100	—	75	55	75	—	100
PITCH CURVE	N	ON/OFF	0	—	25	47	80	—	95
	1	ON/OFF	0	—	25	50	75	—	95
	2	ON/OFF	0	—	25	50	75	—	95
	H	ON/OFF	—	—	—	50	—	—	100

GYRO SENS	RUDD D/R	INH	0	Set gain per Gyro's instruction settings.
		<input type="radio"/> AUTO	1	
			NORM	0
			STNT HOLD	1
		1		

THRO HOLD	<input type="radio"/> ACT	INH	POS
			Set for idle %
	<input type="radio"/> ACT	INH	OFFSET
			%

PROGRAMMABLE MIX	CHANNEL	SW	EXP	0	1	2	3	4	5	6
	MIX1	→		ON/OFF						
	MIX1	→		ON/OFF						
					+POS			-POS		OFFSET
	MIX1	→								
	MIX1	→								
	MIX1	→								

TRIM STEP
AIL 2
ELEV 2
RUDD 1

SWASHPLATE MIXING	AIL	+50
NORM <input type="radio"/> 3 SERVO 120	ELEV	+50
3 SERVO 140	PIT	+60

XP9303 Vibe 90 3D Data Sheet, 140° CCPM

MODEL NO. _____

MODEL NAME _____

	THRO	AIL	ELEV	RUDD	GEAR	PITCH	AUX2	AUX3
REVERSE SW	(NORM REV)	(NORM REV)	(NORM REV)	(NORM REV)	(NORM REV)	(NORM REV)	(NORM REV)	(NORM REV)
SUB TRIM			Adjust so that no Sub Trim is needed					
TRAVEL ADJUST	+ 100% - 100%	L 115% R 115%	U 115% D 115%	L 150% R 150%	L 100% R 100%	U 115% D 115%	+100% - 100%	+100% - 100%
FAIL-SAFE (SPCM)	Set to desired settings							

			AIL	ELEV	RUDD
DUAL RATE/EXP	0	D/R	100%	100%	100%
		EXP	25%	25%	25%
	1	D/R	100%	100%	100%
		EXP	30%	30%	30%

AUTO D/R	POS0	(ACT) INH
	POS1	(ACT) INH
	POS2	(ACT) INH

INPUT SEL	AUX2	HOLD PIT INH
	AUX3	ACT INH
	GEAR	ACT INH

THRO CURVE	EXP	0	1	2	3	4	5	6	
	N	ON/OFF	0	—	56	—	68	74	100
	1	ON/OFF	100	—	75	55	75	—	100
PITCH CURVE	2	ON/OFF	100	—	75	55	75	—	100
	N	ON/OFF	0	—	25	47	80	—	95
	1	ON/OFF	0	—	25	50	75	—	95
	2	ON/OFF	0	—	25	50	75	—	95
	H	ON/OFF	—	—	—	50	—	—	100

GYRO SENS	INH	0	Set gain per Gyro's instruction settings.	
		1		
	RUDD D/R	(AUTO)	NORM	0
			STNT HOLD	1
			1	

THRO HOLD	(ACT) INH	POS
		Set for idle %
	ACT INH	OFFSET
		%

PROGRAMMABLE MIX	CHANNEL	SW	EXP	0	1	2	3	4	5	6
	MIX1	→		ON/OFF						
	MIX1	→		ON/OFF						
					+POS			-POS		OFFSET
	MIX1	→								
	MIX1	→								
	MIX1	→								

TRIM STEP	
AIL	2
ELEV	2
RUDD	1

SWASHPLATE MIXING		AIL	+50
NORM	3 SERVO 120	ELEV	+50
	(3 SERVO 140)	PIT	+60

10X Vibe 90 3D Data Sheet, 120° CCPM

MODEL NO. (84) _____

MODEL NAME (81) _____

Vibe 90 3D

	THRO	AILE	ELEV	RUDD	GEAR	PITCH	AUX2	AUX3	AUX4	AUX5	
REVERSE SW (11)	<input checked="" type="radio"/> R <input type="radio"/> N	<input type="radio"/> R <input checked="" type="radio"/> N	<input checked="" type="radio"/> R <input type="radio"/> N	<input checked="" type="radio"/> R	<input checked="" type="radio"/> N	<input type="radio"/> R <input checked="" type="radio"/> N	<input checked="" type="radio"/> R <input type="radio"/> N	<input type="radio"/> R <input checked="" type="radio"/> N	<input type="radio"/> R <input checked="" type="radio"/> N	<input type="radio"/> R <input checked="" type="radio"/> N	<input type="radio"/> R <input checked="" type="radio"/> N
TRAVEL ADJUST (12)	H 100%	L 115 %	D 115 %	L 150 %	+ 100%	+ 115%	+ 100%	+ 100%	+ 100%	+ 100%	L
SUB-TRIM (15)	100%	R 115 %	U 115 %	R 150 %	100%	115 %	100%	100%	100%	100%	
TRIM RATE (83)											

		AILE	ELEV	RUDD	
D/R EXP (13)	0	D/R	100 %	100 %	100 %
		EXP	25 %	25 %	25 %
		TYPE	LIN/EXP	LIN/EXP	LIN/EXP
	1	D/R	100 %	100 %	100 %
		EXP	30 %	30 %	30 %
		TYPE	LIN/EXP	LIN/EXP	LIN/EXP
2	D/R	100 %	100 %	100 %	
	EXP	30%	30%	30%	
	TYPE	LIN/EXP	LIN/EXP	LIN/EXP	
AUTO D/R (23)	ST-1	INH- <input checked="" type="radio"/> ACT	0- <input checked="" type="radio"/> 1- <input type="radio"/> 2	0- <input checked="" type="radio"/> 1- <input type="radio"/> 2	0- <input checked="" type="radio"/> 1- <input type="radio"/> 2
	ST-2	INH- <input checked="" type="radio"/> ACT	0- <input checked="" type="radio"/> 1- <input type="radio"/> 2	0- <input checked="" type="radio"/> 1- <input type="radio"/> 2	0- <input type="radio"/> 1- <input checked="" type="radio"/> 2
	ST-3	INH- <input type="radio"/> ACT	0- <input type="radio"/> 1- <input checked="" type="radio"/> 2	0- <input type="radio"/> 1- <input checked="" type="radio"/> 2	0- <input type="radio"/> 1- <input checked="" type="radio"/> 2
	ST-4	INH- <input type="radio"/> ACT	0- <input type="radio"/> 1- <input checked="" type="radio"/> 2	0- <input type="radio"/> 1- <input checked="" type="radio"/> 2	0- <input type="radio"/> 1- <input checked="" type="radio"/> 2
	HOLD	INH- <input checked="" type="radio"/> ACT	0- <input type="radio"/> 1- <input checked="" type="radio"/> 2	0- <input type="radio"/> 1- <input checked="" type="radio"/> 2	0- <input type="radio"/> 1- <input checked="" type="radio"/> 2

THROTTLE HOLD (16)	HOLD SW	INH- <input checked="" type="radio"/> HOLD <input type="radio"/> GEAR
	POS	Adjust for idle
	AUTO CUT	INH- <input checked="" type="radio"/> ACT POS
	Delay	1/4 1/2 3/4 1

FUNCTION SELECT (17)	FLIGHT EXTRA GEAR SW	<input checked="" type="radio"/> GEAR <input checked="" type="radio"/> AILE <input checked="" type="radio"/> GEAR <input checked="" type="radio"/> HOLD
	AUX2 SW	INH- <input checked="" type="radio"/> ACT
	PIT. LEVER	LOW HI
	ADT STUNT	INH- <input checked="" type="radio"/> ACT INH- <input checked="" type="radio"/> ACT

GYRO SENS (44)	INH- <input checked="" type="radio"/> AUX3 <input type="radio"/> AUTO	0	Set gain per Gyro's instruction settings			
		1				
		2				
		NR	S1	S2	S3	S4
	0	1	1	1	1	2

	CHANNEL		TRIM	SW	OFFSET	+GAIN	-GAIN	
	MASTER	SLAVE						
PROGRAM MIX (51) - (58)	5	1	INH- <input checked="" type="radio"/> ACT	OFF <input type="radio"/> ON	NR-S1-S2-S3-S4 HD-AX2-GER			
		2	INH- <input checked="" type="radio"/> ACT	OFF <input type="radio"/> ON	NR-S1-S2-S3-S4 HD-AX2-GER			
	5	3	INH- <input type="radio"/> ACT	OFF <input type="radio"/> ON	NR-S1-S2-S3-S4 HD-AX2-GER	EXP	L 1 2 3 4 5 6 H	
		5	INH- <input checked="" type="radio"/> ACT	OFF <input type="radio"/> ON	NR-S1-S2-S3-S4 HD-AX2-GER	OFF ON	IN 0 OUT	100
	5	7	INH- <input checked="" type="radio"/> ACT	OFF <input type="radio"/> ON	NR-S1-S2-S3-S4 HD-AX2-GER	OFF ON	IN 0 OUT	100
		8	INH- <input checked="" type="radio"/> ACT	OFF <input type="radio"/> ON	NR-S1-S2-S3-S4 HD-AX2-GER	OFF ON	IN 0 OUT	100

		EXP		L	1	2	3	4	5	6	H
THRO CURVE (18) TH,TRIM=SLOW HOV.T=CENTER	N	OFF	IN	0	13	28	74	80	_____	_____	100
		ON	OUT	0	47	56	68	74	_____	_____	100
			HOV.SEL	---	HOV	HOV	HOV	HOV	HOV	HOV	HOV
	1	OFF	IN	0	25	48	75	_____	_____	_____	100
		ON	OUT	100	75	55	75	_____	_____	_____	100
	2	OFF	IN	0	25	48	74	88	_____	_____	100
		ON	OUT	100	75	55	75	_____	_____	_____	100
	3	OFF	IN	0	_____	_____	_____	_____	_____	_____	100
		ON	OUT	0	_____	_____	_____	_____	_____	_____	100
	4	OFF	IN	0	_____	_____	_____	_____	_____	_____	100
		ON	OUT	_____	_____	_____	_____	_____	_____	_____	_____
	PITCH CURVE (68) P,TRIM=CENTER HOV.P=CENTER	N	OFF	IN	0	13	32	80	_____	_____	_____
ON			OUT	0	25	47	80	_____	_____	_____	97
			HOV.SEL	---	HOV	HOV	HOV	HOV	HOV	HOV	HOV
1		OFF	IN	0	12	85	_____	_____	_____	_____	100
		ON	OUT	0	16	88	_____	_____	_____	_____	95
2		OFF	IN	0	12	85	_____	_____	_____	_____	100
		ON	OUT	0	16	88	_____	_____	_____	_____	95
3		OFF	IN	0	_____	_____	_____	_____	_____	_____	100
		ON	OUT	_____	_____	_____	_____	_____	_____	_____	_____
4		OFF	IN	0	_____	_____	_____	_____	_____	_____	100
		ON	OUT	_____	_____	_____	_____	_____	_____	_____	_____
HOLD		OFF	IN	0	50	_____	_____	_____	_____	_____	100
	ON	OUT	0	60	_____	_____	_____	_____	_____	100	

Rudder Throttle 4 1 MIX (41)		+15%
		-15%
MODESELECTION	NR-S1-S2-S3-S4-AX2	

FAIL-SAFE (77)	Z	MODE	HOLD • 1.0s • 0.5s • 0.25s
		MEMORY	
	S	MEMORY	THROTTLE 1/4 STICK

Aileron Throttle 2 1 MIX (42)		+20%
		-20%
MODESELECTION	NR-S1-S2-S3-S4-AX2	

SWASHPLATE MIXING TYPE (65)	1SERVO • <u>SERVO-120°CCPM</u> • 3SERVO-140°CCPM			
	1SERVO	ELE AL	D	%
			U	%
	SWITCH	AL ELE	L	%
		R	%	
3SERVO 120°CCPM	AL	ELE	50 %	PTT +60 %
3SERVO 140°CCPM	AL	%	ELE %	PTT %

Elevator Throttle 3 1 MIX (43)		+20%
		-20%
MODESELECTION	NR-S1-S2-S3-S4-AX2	

10X Vibe 90 3D Data Sheet, 140° CCPM

MODEL NO. (84) _____

MODEL NAME (81) _____

Vibe 90 3D

	THRO	AILE	ELEV	RUDD	GEAR	PITCH	AUX2	AUX3	AUX4	AUX5	
REVERSE SW (11)	<input checked="" type="radio"/> R <input type="radio"/> N	<input type="radio"/> R <input checked="" type="radio"/> N	<input checked="" type="radio"/> R <input type="radio"/> N	<input checked="" type="radio"/> R	<input checked="" type="radio"/> N	<input type="radio"/> N	<input checked="" type="radio"/> R <input type="radio"/> N	<input checked="" type="radio"/> R <input type="radio"/> N	<input checked="" type="radio"/> R <input type="radio"/> N	<input checked="" type="radio"/> R <input type="radio"/> N	<input checked="" type="radio"/> R <input type="radio"/> N
TRAVEL ADJUST (12)	H 100%	L 115 %	D 115 %	L 150 %	100%	115%	150%	150%	150%	150%	150% L
SUB-TRIM (15)	100%	R 115 %	U 115 %	R 150 %	100%	115%	150%	150%	150%	150%	
TRIM RATE (83)	Adjust so that no Sub-Trim is needed										

		AILE	ELEV	RUDD	
D/R EXP (13)	0	D/R	100 %	100 %	100 %
		EXP	25 %	25 %	25 %
		TYPE	LIN/EXP	LIN/EXP	LIN/EXP
	1	D/R	100 %	100 %	100 %
		EXP	30 %	30 %	30 %
		TYPE	LIN/EXP	LIN/EXP	LIN/EXP
2	D/R	100 %	100 %	100 %	
	EXP	30%	30%	30%	
	TYPE	LIN/EXP	LIN/EXP	LIN/EXP	
AUTO D/R (23)	ST-1	INH- <input checked="" type="radio"/> ACT	0 - <input checked="" type="radio"/> 1 - <input type="radio"/> 2	0 - <input checked="" type="radio"/> 1 - <input type="radio"/> 2	0 - <input checked="" type="radio"/> 1 - <input type="radio"/> 2
	ST-2	INH- <input checked="" type="radio"/> ACT	0 - <input checked="" type="radio"/> 1 - <input type="radio"/> 2	0 - <input checked="" type="radio"/> 1 - <input type="radio"/> 2	0 - <input type="radio"/> 1 - <input checked="" type="radio"/> 2
	ST-3	INH- <input type="radio"/> ACT	0 - <input type="radio"/> 1 - <input checked="" type="radio"/> 2	0 - <input type="radio"/> 1 - <input checked="" type="radio"/> 2	0 - <input type="radio"/> 1 - <input checked="" type="radio"/> 2
	ST-4	INH- <input type="radio"/> ACT	0 - <input type="radio"/> 1 - <input checked="" type="radio"/> 2	0 - <input type="radio"/> 1 - <input checked="" type="radio"/> 2	0 - <input type="radio"/> 1 - <input checked="" type="radio"/> 2
	HOLD	INH- <input checked="" type="radio"/> ACT	0 - <input type="radio"/> 1 - <input checked="" type="radio"/> 2	0 - <input type="radio"/> 1 - <input checked="" type="radio"/> 2	0 - <input type="radio"/> 1 - <input checked="" type="radio"/> 2

THROTTLE HOLD (16)	HOLD SW	INH- <input checked="" type="radio"/> GEAR
	POS	Adjust for idle
	AUTO CUT	INH- <input type="radio"/> ACT POS
	Delay	1/4 1/2 3/4 1

FUNCTION SELECT (17)	FLIGHT EXTRA GEAR	<input checked="" type="radio"/> GEAR <input checked="" type="radio"/> AILE <input checked="" type="radio"/> GEAR	
	SW	<input checked="" type="radio"/> HOLD	
	AUX2 SW	INH- <input type="radio"/> ACT	
	PIT. LEVER	LOW	INH- <input type="radio"/> ACT
		HI	INH- <input type="radio"/> ACT
	ADT STUNT	INH- <input checked="" type="radio"/> ACT	

GYRO SENS (44)	INH- <input type="radio"/> AUX3 <input type="radio"/> AUTO	0	Set gain per Gyro's instruction settings					
		1						
		2						
			NR	S1	S2	S3	S4	HD
		0	1	1	1	1	2	

			CHANNEL	TRIM	SW	OFFSET	+GAIN	-GAIN	
			MASTER	SLAVE					
PROGRAM MIX (51) - (58)	5	1	INH		OFF	NR-S1-S2-S3-S4			
		ACT		ON	HD-AX2-GER				
	5	2	INH		OFF	NR-S1-S2-S3-S4			
		ACT		ON	HD-AX2-GER				
	5	3	INH		OFF	NR-S1-S2-S3-S4			
		ACT		ON	HD-AX2-GER				
	5	5	INH		OFF	NR-S1-S2-S3-S4	EXP	IN 0	100
		ACT		ON	HD-AX2-GER	ON	OUT	-	---
5	7	INH		OFF	NR-S1-S2-S3-S4	EXP	IN 0	100	
	ACT		ON	HD-AX2-GER	ON	OUT			
5	8	INH		OFF	NR-S1-S2-S3-S4	EXP	IN 0	100	
	ACT		ON	HD-AX2-GER	ON	OUT			

		EXP		L	1	2	3	4	5	6	H
THRO CURVE (18) TH,TRIM=SLOW HOV.T=CENTER	N	OFF	IN	0	13	28	74	80	_____	_____	100
		ON	OUT	0	47	56	68	74	_____	_____	100
			HOV.SEL	---	HOV	HOV	HOV	HOV	HOV	HOV	HOV
	1	OFF	IN	0	25	48	75	_____	_____	_____	100
		ON	OUT	100	75	55	75	_____	_____	_____	100
	2	OFF	IN	0	25	48	74	88	_____	_____	100
		ON	OUT	100	75	55	75	_____	_____	_____	100
	3	OFF	IN	0	_____	_____	_____	_____	_____	_____	100
		ON	OUT	0	_____	_____	_____	_____	_____	_____	100
	4	OFF	IN	0	_____	_____	_____	_____	_____	_____	100
		ON	OUT	_____	_____	_____	_____	_____	_____	_____	_____
	PITCH CURVE (68) P,TRIM=CENTER HOV.P=CENTER	N	OFF	IN	0	13	32	80	_____	_____	_____
ON			OUT	0	25	47	80	_____	_____	_____	97
			HOV.SEL	---	HOV	HOV	HOV	HOV	HOV	HOV	HOV
1		OFF	IN	0	12	85	_____	_____	_____	_____	100
		ON	OUT	0	16	88	_____	_____	_____	_____	95
2		OFF	IN	0	12	85	_____	_____	_____	_____	100
		ON	OUT	0	16	88	_____	_____	_____	_____	95
3		OFF	IN	0	_____	_____	_____	_____	_____	_____	100
		ON	OUT	_____	_____	_____	_____	_____	_____	_____	_____
4		OFF	IN	0	_____	_____	_____	_____	_____	_____	100
		ON	OUT	_____	_____	_____	_____	_____	_____	_____	_____
HOLD		OFF	IN	0	50	_____	_____	_____	_____	_____	100
	ON	OUT	0	60	_____	_____	_____	_____	_____	100	

Rudder Throttle		+15%
4 1		
MIX (41)		-15%
MODE SELECTION	NR-S1-S2-S3-S4-AX2	

FAIL-SAFE (77)	Z	MODE	HOLD • 1.0s • 0.5s • 0.25s
		MEMORY	
	S	MEMORY	THROTTLE 1/4 STICK

Aileron Throttle		+20%
2 1		
MIX (42)		-20%
MODE SELECTION	NR-S1-S2-S3-S4-AX2	

SWASHPLATE MIXING TYPE (65)	1SERVO • 3SERVO-120°CCPM • 4SERVO-140°CCPM			
	1SERVO	ELE AL	D	%
			U	%
	SWITCH	AL ELE	L	%
		R	%	
3SERVO 120°CCPM	AL	%	ELE	%
3SERVO 140°CCPM	AL		ELE	50%
			PTT	+60%

Elevator Throttle		+20%
3 1		
MIX (43)		-20%
MODE SELECTION	NR-S1-S2-S3-S4-AX2	



START SHAFT/CLUTCH/ENGINE ASSEMBLY

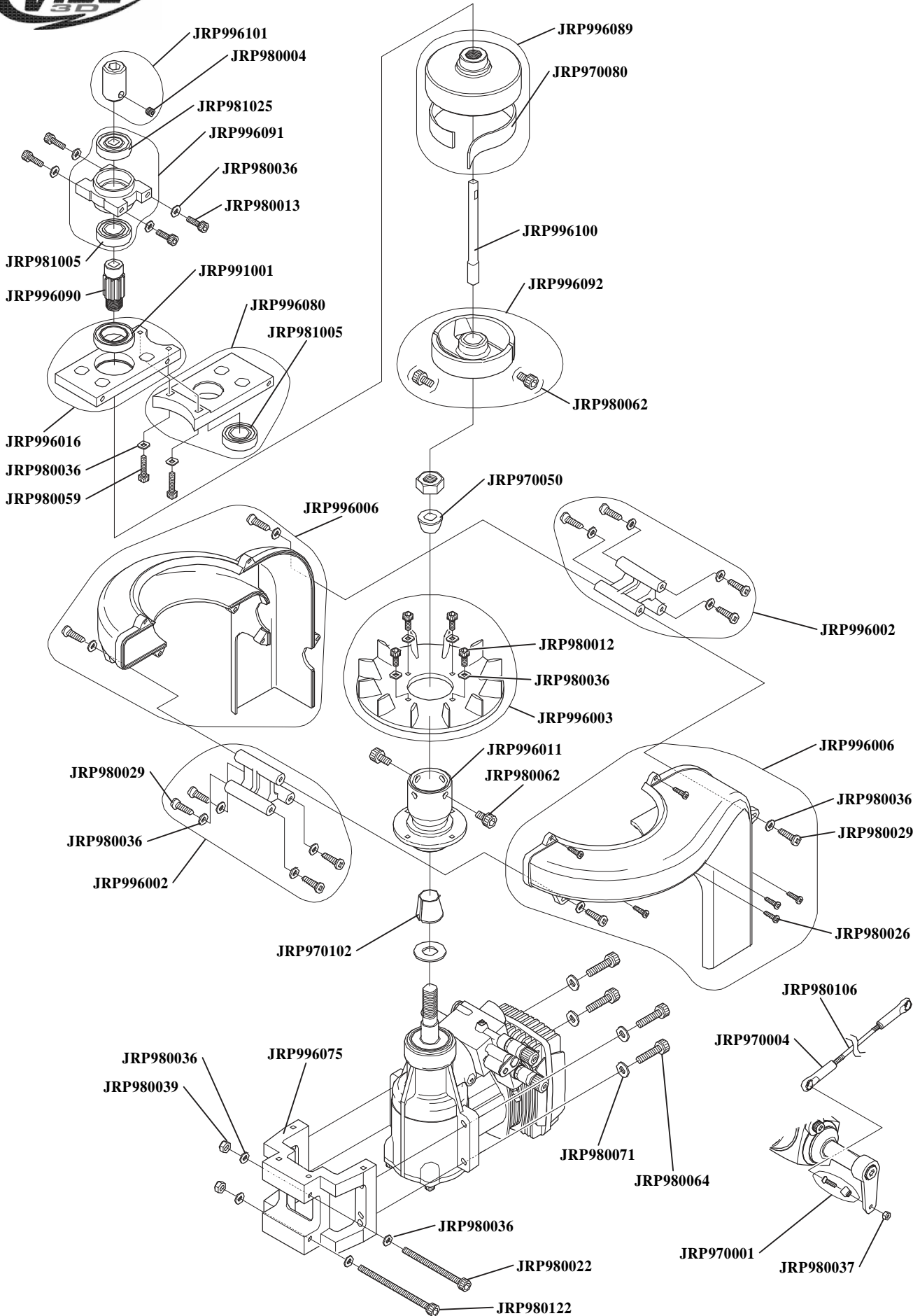

VIBE 90 3D MANUAL PARTS LISTINGS
Start Shaft/ Clutch/ Engine Assembly

Part #	Description	Quantity	Comments/ Additional Contents
996101	Hex Shaft Adaptor	1	Complete w/ 4 x 4 mm set screw
980004	Set Screw, 4 x 4 mm	10	
981025	Bearing, Sealed, 5 x 19 x 6 mm	2	
996091	Start Shaft Bearing Block w/BB	1	
980036	Flat Washer, 3 mm	10	
980013	Socket Head Bolt, 3 x 8 mm	10	
996089	Clutch Bell Assembly w/BB	1	Complete w/bearing & clutch lining
970080	Clutch lining	1	
996100	Start Shaft	1	
996092	Clutch Assembly	1	Complete w/two 4 x 6 mm bolts
980062	Socket Head Bolt, 4 x 6 mm	10	
981005	Ball Bearing, 10 x 19 x 7 mm	2	
996090	Pinion Gear, 11 Tooth	1	
991001	Ball Bearing, 15 x 24 x 5 mm	1	
996080	Long Bearing Block "B"	1	Complete w/bearing
996016	Long Bearing Block "A"	1	Complete w/bearing
980059	Socket Head Bolt, 3 x 14 mm	10	
970050	Taper Collet "B", Upper	1	
996006	Cooling Fan Shroud	1	1-left, 1-right half complete w/screws
996002	Cooling Shroud Brackets	2	Complete w/screws and washers
996003	Cooling Fan Blades	1	Complete w/screws and washers
996011	Cooling Fan Hub	1	
980062	Socket Head Bolt, 4 x 6 mm	10	
970001	Steel Joint Ball w/2 x 8 mm Screw	10	Complete w/ten 2 x 8 mm screws
980037	Hex Nut, 2 mm	10	
970004	Universal Ball Link	10	
996075	Engine Mount	1	
970102	Taper Collet "C", Lower	1	



MAIN FRAME/LANDING GEAR/AUTOROTATION ASSEMBLY

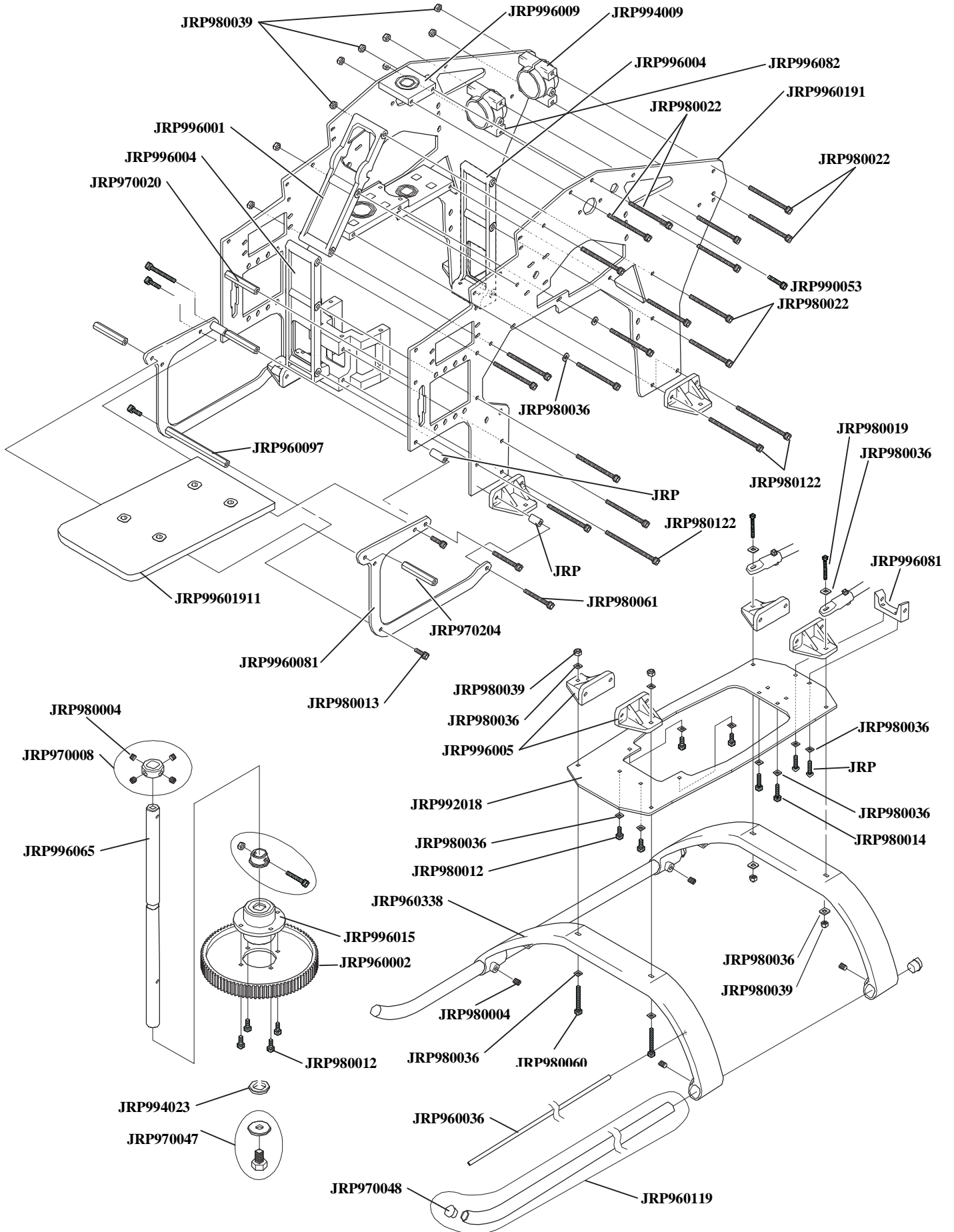

VIBE 90 3D MANUAL PARTS LISTINGS
Main Frame/Landing Gear/Autorotation Assembly

Part #	Description	Quantity	Comments/ Additional Contents
980039	Nylon Lock Nut, 3 mm Low Profile	10	
996009	Upper Main Shaft Bearing Block w/BB	1	Complete with ball bearing
996082	Tail Boom Mounting Clamp, 2-piece	1	
994009	Tail Boom Mounting Clamp, 1-piece	1	
996004	I-Beam Cross member "B"	2	
9960191	Main Frame Set	1	Complete Set (2 pcs)
980022	Socket Head Bolt, 3 x 40 mm	10	
996001	I-Beam Cross member "A"	1	
970020	Main Frame Cross member, 32 mm	2	
980061	Socket Head Bolt, 3 x 25 mm	10	
980014	Socket Head Bolt, 3 x 10 mm	10	
990053	Socket Head Bolt, 3.5 x 6 mm	10	
970018	Mixing Lever Spacer	2	
980036	Flat Washer, 3 mm	10	
980019	Socket Head Bolt, 3 x 22 mm	10	
980122	Socket Head Bolt, 3 x 50 mm	10	
980013	Socket Head Bolt, 3 x 8 mm	10	
960097	Main Frame Cross member, 48 mm	2	
9960081	Fuel Tank Mounting Frames	2	
970204	Canopy Mounting Standoff	2	
99601911	Front Radio Bed	1	
980004	Set Screw, 4 x 4 mm	10	
970008	Main Shaft Collar	1	Complete w/four 4 x 4 mm set screws
996065	Main Rotor Shaft, Hardened	1	
996005	Landing Strut Mounts	4	
980014	Socket Head Bolt, 3 x 10 mm	10	
992018	Carbon Bottom Frame Plate	1	
996081	Rear Grounding Bracket	1	
980012	Socket Head Bolt, 3 x 6 mm	10	
960338	Landing Struts, White	2	
980004	Set Screw, 4 x 4 mm	10	
980060	Socket Head Bolt, 3 x 20 mm	10	
960036	Antenna Tube	3	
960119	Landing Skids	2	Complete w/four skid caps
970048	Landing Skid Caps	4	
996015	Autorotation Assembly	1	
960002	88T Molded Main Drive Gear	1	(standard)
970047	Main Shaft Washer and Bolt	1	Complete w/one 6 x 10 mm hex bolt
994001	Steel Auto Hub Washer	1	

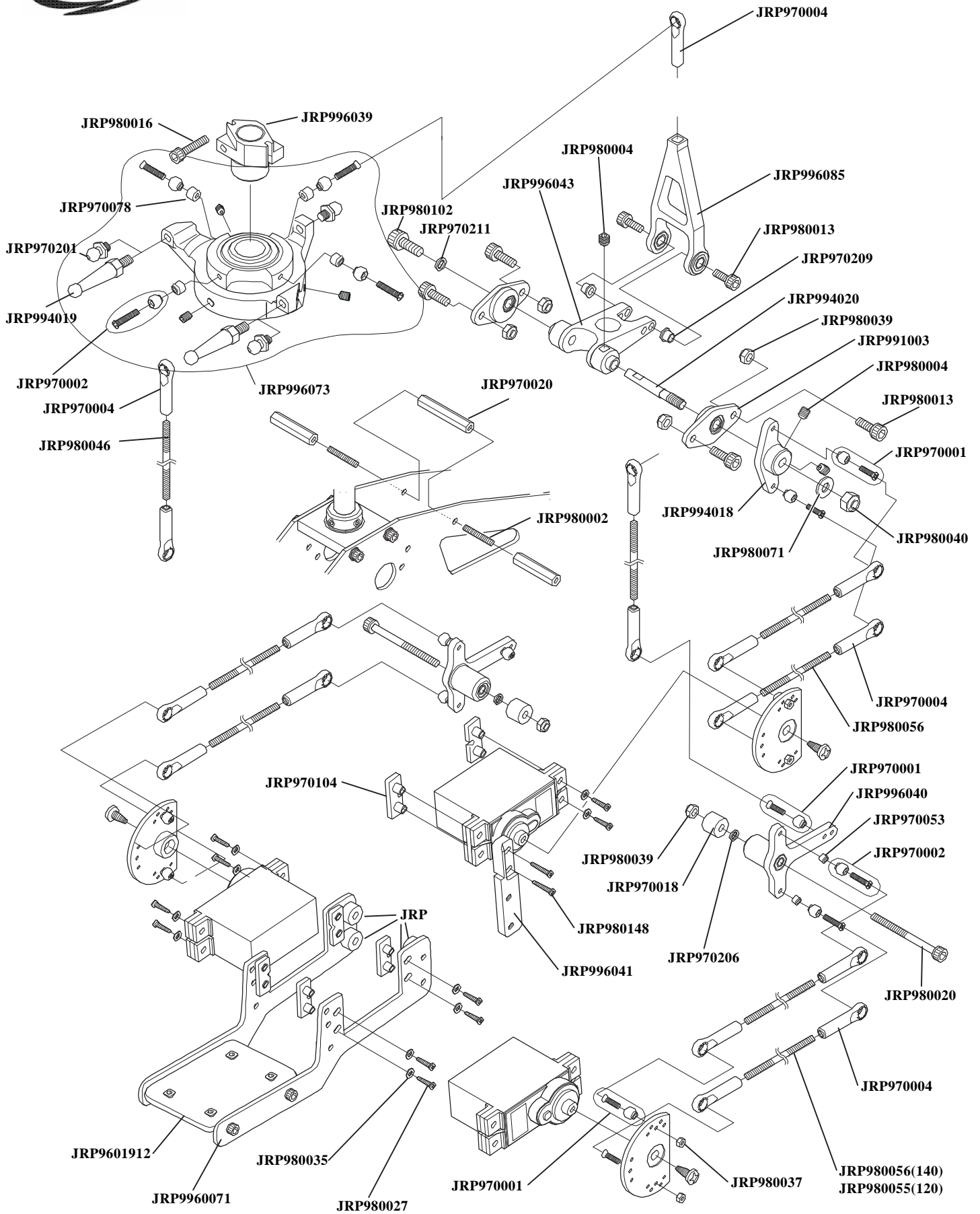

VIBE 90 3D MANUAL PARTS LISTINGS
Swashplate/CCPM Control System

Part #	Description	Quantity	Comments/ Additional Contents
JRP970001	Joint Balls w/8 mm Screws	10	
JRP970002	Joint Balls w/10 mm Screws	10	
JRP970004	Universal Links	10	
JRP970018	Mixing Lever Spacer	2	
JRP970020	Main Frame Standoff, 32 mm	2	
JRP970053	Control Ball Spacer	2	
JRP970078	Control Ball Spacer, 2.75 mm	2	
JRP970082	Washer, 3 x 4.5 x 4 mm	2	
JRP970104	Servo Mounting Plates	8	
JRP970201	Control Ball, 4 mm	2	
JRP970206	CCPM T Lever Spacer	2	
JRP970209	CCPM A Arm Collar	2	
JRP970211	Shaft Washer, CCPM	2	
JRP980002	Set Screws, 3 x 4 mm	10	
JRP980004	Set Screws, 4 x 4 mm	10	
JRP980013	Socket Head Bolts, 3 x 8 mm	10	
JRP980016	Socket Head Bolts, 3 x 15 mm	10	
JRP980020	Socket Head Bolts, 3 x 28 mm	10	
JRP980022	Socket Head Bolts, 3 x 40 mm	10	
JRP980027	Self Tapping Screws, 2 x 8 mm	10	
JRP980035	Plate Washer, 2.6 mm	10	
JRP980037	Hex Nuts, 2 mm	10	
JRP980039	Nylon Lock Nuts, 3 mm	10	
JRP980040	Nylon Lock Nuts, 4 mm	10	
JRP980046	Control Rod, 2.3 x 60 mm	2	
JRP980056	Control Rod, 2.3 x 85 mm	2	
JRP980067	Set Screws, 3 x 3 mm	10	
JRP980071	Plate Washers, 4 mm	10	
JRP980102	Socket Head Bolts, 4 x 10 mm	10	
JRP980148	Self Tapping Screws, 2.6 x 15 mm	10	
JRP991003	CCPM Control Arm Block w/BB	1	
JRP994018	CCPM Elevator Control Arm	1	
JRP994019	Control Ball, 20 mm	2	
JRP994020	CCPM Control Arm Shaft	1	
JRP996073	CCPM Swashplate Assembly	1	Complete with control balls and screws
JRP996040	CCPM T Lever Assembly w/BB	1	
JRP996041	CCPM Top Servo Mounting Post	1	
JRP996085	CCPM A-Arm Assembly	1	
JRP996043	CCPM Elevator Arm Assembly	1	
JRP996039	Aluminum Washout Base	1	
JRP9960071	Carbon Upper Servo Mount	2	
JRP9601912	Carbon Upper Gyro Tray	1	
JRP99	2.5 mm Spacers	4	
JRP980055	Control Rod, 2.3 x 70 mm	2	

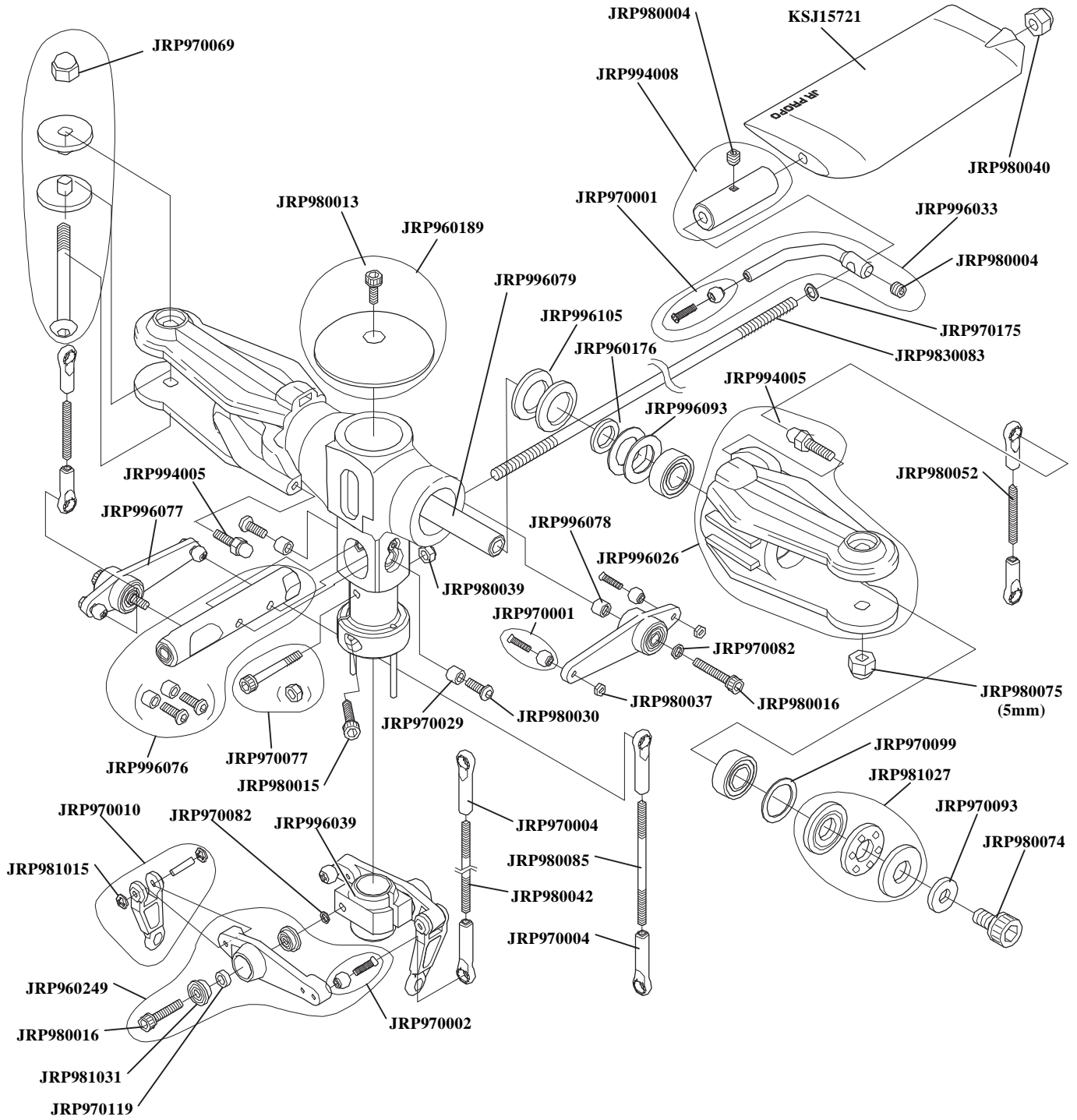

VIBE 90 3D MANUAL PARTS LISTINGS
Main Rotor Head/ Washout Assembly

Part #	Description	Quantity	Comments/ Additional Contents
980013	Socket Head Bolt, 3 x 8 mm	10	
980004	Set Screw, 4 x 4 mm	10	
KSJ15721	3D Flybar Paddles	2	
994008	Flybar Weights	2	Complete w/set screws
960189	Head Button	1	Complete w/one 3 x 8 mm socket head bolts
996079	Blade Spindle Shaft	1	Complete w/two 5 x 10 mm socket head bolts
980040	Nylon Lock Nut, 4 mm	10	
996033	Flybar Control Arm	2	Complete w/steel joint ball and screws
996105	O-Ring Dampeners, 8pc (2 hard, 2 soft)	4	
996074	Main Rotor Hub	1	
970098	Universal Ball Link (short)	10	
994005	Control Ball, 14 mm	2	
980001	Set Screw, 3 x 4 mm	10	
980052	Control Rod, 2.3 x 15 mm	2	
996077	Seesaw Mixing Arm Assm. w/BB	1	Complete w/all hardware
980039	Nylon Lock Nut, 3 mm Low Profile	10	
970115	Washer, .03 x 4.5 x 0.7	10	
996026	Main Blade Holder	2	
996099	Blade Grip Control Ball, 14mm	2	
970082	Washer, .03 x 4.5 x 0.4	10	
980037	Hex nut, 2 mm	10	
980030	Button Head Bolt, 3 x 5 mm	10	
970069	Blade Bolts w/Spacers	2	Complete w/two 4 mm bolts, and 12 mm grip spacers
980075	Nylon Lock Nut. 5mm	10	
980016	Socket Head Bolt, 3 x 15 mm	10	
970029	Seesaw Spacer Collar	2	
970077	Main Rotor Shaft Bolt, 3 x 22 mm	2	Complete w/two lock nuts and washers
996076	Seesaw Shaft Assembly	1	Complete w/all hardware
970010	Washout Link	2	Complete w/all hardware
981015	CA Stopper Ring	10	
960013	Washout Base	1	
970004	Universal Ball Link	10	
980085	Control Rod, 2.3 x 55 mm	2	
980042	Control Rod, 2.3 x 30 mm	2	
981026	Bearing, 8 x 16 x 5 mm	2	
970099	Washer, 12 x 16 x 0.5 mm	2	
981027	Thrust Bearing, 8 x 16 x 5 mm	2	
970093	Spindle Shaft Washer	2	
980074	Socket Head Bolt, 5 x 10 mm	10	
960249	Washout Arm w/BB	1	Complete w/all hardware
980016	Socket Head Bolt, 3 x 15 mm	10	
981031	Bearing w/Flange, 3 x 8 x 4 mm	2	
970119	Spacer, 3 x 5 x 1.8 mm	2	
996078	Seesaw Mixing Arm Collars	2	
996093	Head Spacers (4)	4	
9830083	Flybar, 530 mm	1	

VIBE⁹⁰ 3D TAIL DRIVE SYSTEM/SHAFT DRIVE PARTS

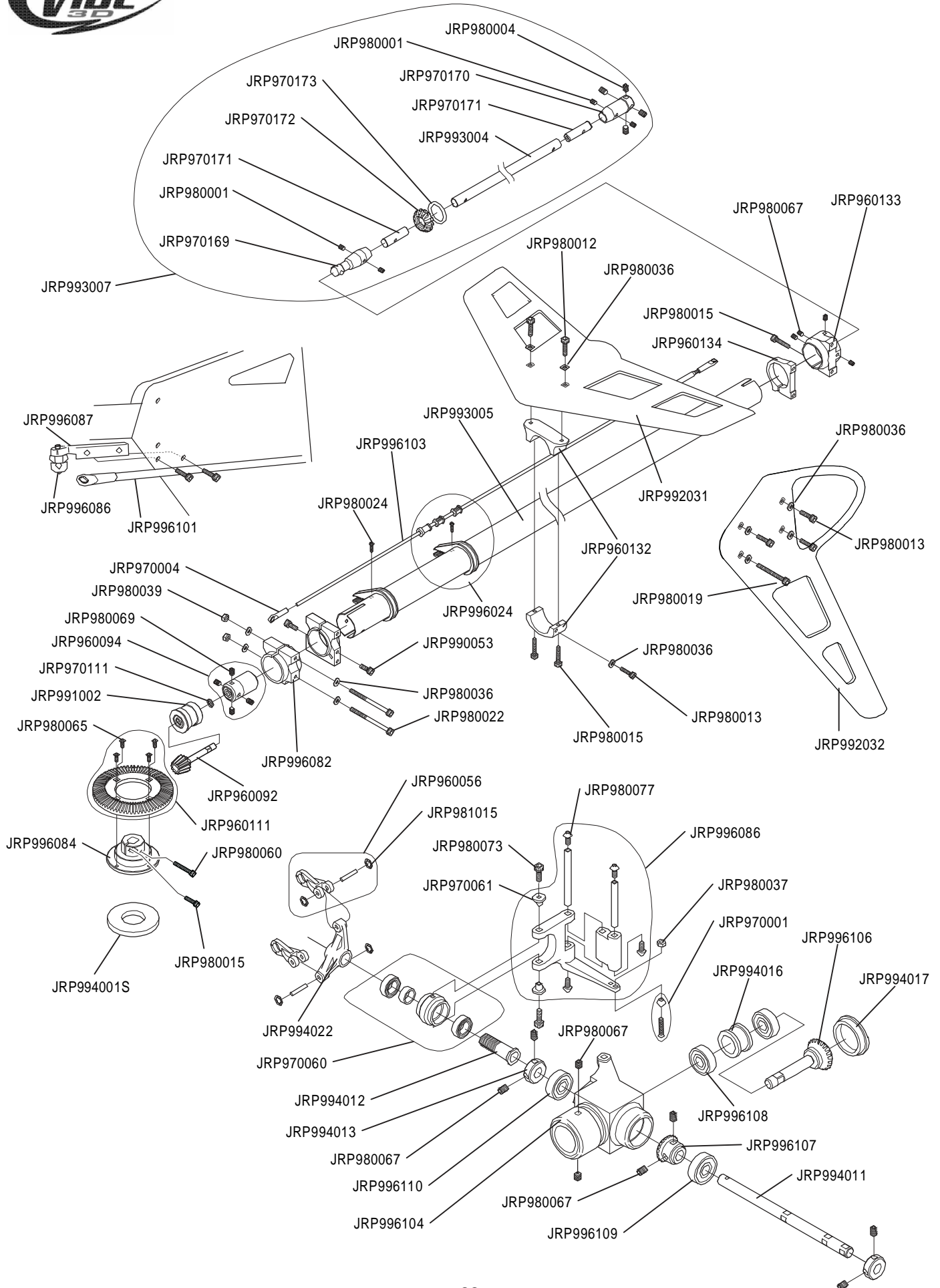

VIBE 90 3D MANUAL PARTS LISTINGS
Tail Drive System/Shaft Drive Parts

Part #	Description	Quantity	Comments/ Additional Contents
JRP960056	Tail Pitch Link 2		
JRP960092	Bevel Front Pinion Gear (Metal)	1	
JRP960094	Tube Drive Joint, Front	1	
JRP960111	Bevel Tail Drive Gear (Plastic)	1	Complete with screws
JRP960132	Aluminum Tail Support Clamp	1	
JRP960133	Tail Gear Box Clamp A	1	
JRP960134	Tail Gear Box Clamp B	1	
JRP970001	Joint Balls w/8 mm Screws	10	
JRP970004	Joint Balls w/10 mm Screws	10	
JRP970060	Tail Pitch Slider Assembly	1	
JRP970061	Tail Control Arm Collar	1	
JRP970081	Control Rod Ends	2	
JRP970111	Washer, 8 x 9 x 1 mm	2	
JRP970169	Shaft Drive Universal, Front	1	
JRP970170	Shaft Drive Joint, Rear	1	
JRP970171	Shaft Drive Tube Inserts	2	
JRP970172	Shaft Drive Guides w/Bearings	2	
JRP970173	Shaft Drive Guide O-Rings	2	
JRP980001	Set Screws, 3 x 4 mm	10	
JRP980004	Set Screws, 4 x 4 mm	10	
JRP980012	Socket Head Bolts, 3 x 6 mm	10	
JRP980015	Socket Head Bolts, 3 x 12 mm	10	
JRP980019	Socket Head Bolts, 3 x 22 mm	10	
JRP980022	Socket Head Bolts, 3 x 40 mm	10	
JRP980024	Self Tapping Screws, 2 x 8 mm	10	
JRP980036	Plate Washer, 3 mm	10	
JRP980037	Hex Nuts, 2 mm	10	
JRP980039	Nylon Lock Nuts, 3 mm	10	
JRP980060	Socket Head Bolts, 3 x 20 mm	10	
JRP980065	Flat Head Bolts, 3 x 6 mm	10	
JRP980067	Set Screws, 3 x 3 mm	10	
JRP980069	Set Screws, 4 x 6 mm	10	
JRP980073	Socket Head Bolts, 2 x 6 mm	10	
JRP980077	Self Tapping Screws, 2 x 4 mm	10	
JRP981015	CA Stopper Ring, 2 mm	10	
JRP990053	Socket Head Bolts, 3.5 x 6 mm	2	
JRP991002	Front Pinion Case w/ Bearings	1	
JRP993004	Tail Drive Shaft, Aluminum	1	
JRP993005	Tail Boom, Aluminum	1	
JRP993006	Tail Brace Set (Black)	1	Complete with all hardware
JRP993007	Tail Drive Shaft Assm. Complete	1	Complete with all hardware
JRP996082	Tail Boom Mounting Clamp, 2 piece	1	
JRP994011	Tail Output Shaft	1	
JRP994012	Tail Slide Ring Sleeve	1	
JRP994013	Tail Output Shaft Collar	2	
JRP996106	Tail Case Input Gear w/ Shaft	1	
JRP996107	Tail Case Output Gear	1	
JRP994016	Tail Case Input Gear Collar	1	
JRP994017	Tail Case Rear Cap	1	
JRP994022	Tail Pitch Plate	1	
JRP996024	Tail Guide Clamp Set	1	One complete set with screws
JRP996084	Split Gear Hub Adapter	1	
JRP996104	Tail Gear Case Set	1	
JRP996086	CNC BB Tail Case Control Lever	1	
JRP996103	Stainless Steel Tail Control Rod, Long	1	
JRP992031	CF Tail Fin, Horizontal	1	
JRP992032	CF Tail Fin, Vertical	1	
JRP994001S	Special Washer 16 x 10 mm	1	
JRP996108	Tail Case Bearing, 10 x 5 mm	2	
JRP996109	Tail Case Bearing, 14 x 5 mm	1	
JRP996110	Tail Case Bearing, 13 x 5 mm	1	

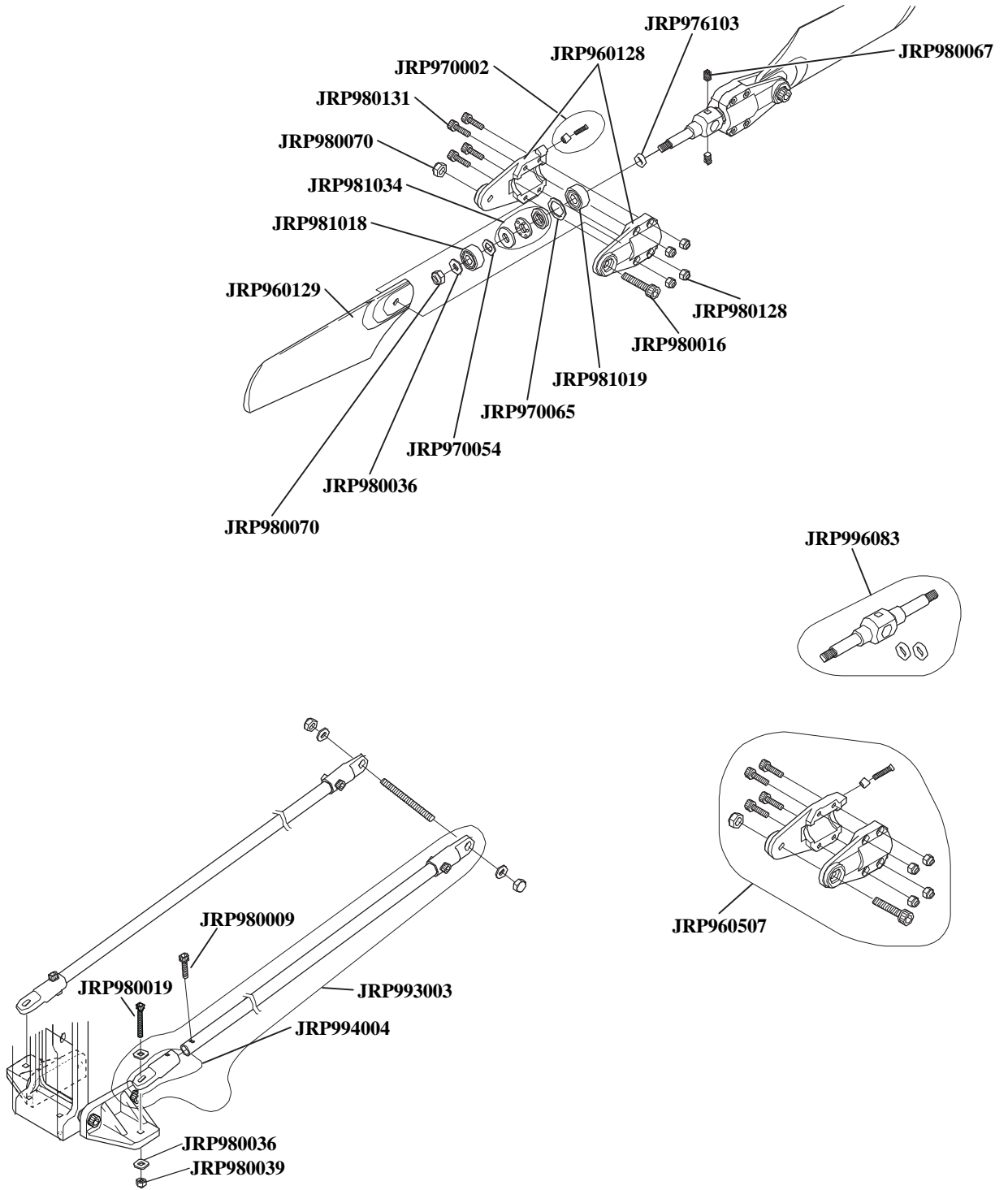

VIBE 90 3D MANUAL PARTS LISTINGS
Tail Brace/ Tail Boom Assembly

Part #	Description	Quantity	Comments/ Additional Contents
994004	Tail Brace Connector	1	Complete w/bolt
960047	Tail Brace Tube	2	
980009	Socket Head Bolt, 2.6 x 12 mm	10	
980036	Flat Washer, 3 mm	10	
980070	Nylon Lock Nut, 3 mm	10	
993003	Tail Brace Set 1 Two brace tubes	4	brace connectors and hardware
970002	Steel Joint Ball w/ 2 x 10 mm Screw	10	Complete w/ten 2 x 8 mm screws
960128	Tail Blade Holder Set	1	One complete set (4 pcs)
976103	O-Ring, Tail Hub	2	
980131	Socket Head Bolt, 2 x 10 mm	10	
981034	Thrust Bearing, 4 x 9 x 4 mm	2	
981018	Open Bearing, 4 x 10 x 4 mm	2	
960129	Tail Rotor Blades	2	
970054	Washer, 4 x 7 x 0.5 mm	2	
970065	Washer, 7 x 10 x 1 mm	2	
981019	Sealed Bearing, 4 x 10 x 4 mm	2	
980128	Nylon Lock Nut, 2 mm	10	
980067	Set Screw, 3 x 3 mm	10	
970018	Mixing Lever Spacer	2	
960507	Tail Blade Holder Set w/Hardware	1	One complete set (4 pcs) with hardware
996083	Tail Center Hub w/O-Rings	1	Complete w/two O-rings

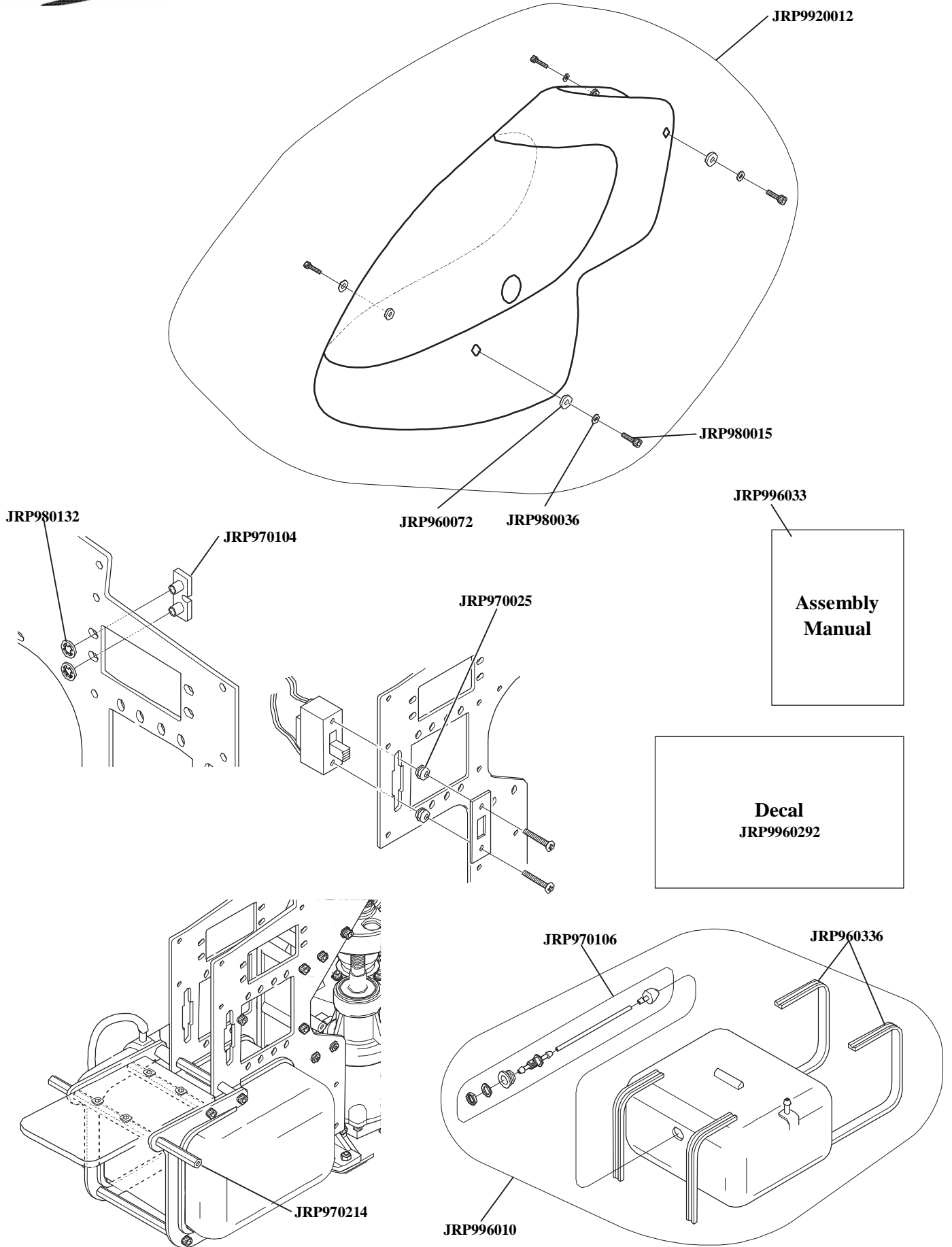

VIBE 90 3D MANUAL PARTS LISTINGS
Body Set/ Fuel Tank Assembly

Part #	Description	Quantity	Comments/ Additional Contents
9920012	Vibe Body Set	1	
960072	Rubber Body Grommets	4	
980036	Flat Washer, 3 mm	10	
980015	Socket Head Bolt, 3 x 12 mm	10	
980132	CA Stopper Ring, 3.5 mm	10	
970104	Servo Mounting Plates, Type B	10	
970025	Switch Mounting Grommets	4	
990051	Threaded Rod, 3 x 50 mm	2	
994006	Main Frame Standoff, 41 mm	2	
980013	Socket Head Bolt, 3 x 8 mm	10	
970214	Main Frame Standoff, 21 mm	2	
970106	Fuel Tank Hardware Set	1	Complete with stopper, clunk, nut, and washer
996010	Vigor Fuel Tank Set	1	Complete with all tank hardware
960336	Tank Mounting Rubber (3 ft)	1	
996033	Vibe 90 3D Instruction Manual	1	
9960292	Vibe 90 3D Decal Set	1	

VIBE 90 3D WARRANTY INFORMATION

Horizon Hobby, Inc. guarantees this kit to be free from defects in both material and workmanship at the date of purchase. This warranty does not cover any parts damaged by use or modification. In no case shall Horizon Hobby's liability exceed the original cost of the purchased kit. Further, Horizon Hobby reserves the right to change or modify this warranty without notice.

This warranty covers only those products purchased from an authorized Horizon Hobby dealer. Third party transactions are not covered by this warranty. Proof of purchase is required for warranty claims. Horizon Hobby, Inc. reserves the right to inspect any and all equipment involved in a warranty claim. Repair or replacement decisions are at the sole discretion of Horizon Hobby, Inc. Collateral damage of any type is not covered under this warranty.

In that Horizon Hobby has no control over the final assembly or material used for the final assembly, no liability shall be assumed nor accepted for any damage of or caused by the final user-assembled product. By the act of using the product, the user accepts all resulting liability.

Once assembly of the model has been started, you must contact Horizon Hobby, Inc. directly regarding any warranty question that you have. Please do not contact your local hobby store regarding warranty issues, even if that is where you purchased it. This will enable Horizon to better answer your questions and provide service in the event that you may need any assistance.

If the buyer or user is not prepared to accept the liability associated with the use of this product, they are advised to return this kit immediately in new and unused condition to the place of purchase.

For any additional questions please contact:
Horizon Hobby Product Support
4105 Fieldstone Road
Champaign, Illinois 61822
(877) 504-0233
productsupport@horizonhobby.com



Distributed exclusively by
Horizon Hobby, Inc.
4105 Fieldstone Road
Champaign, IL 61822

www.horizonhobby.com