

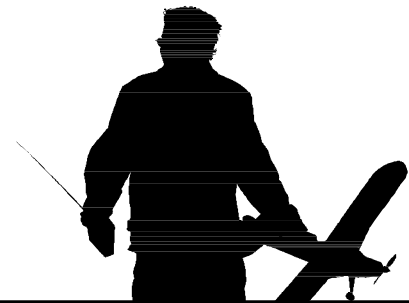

# *Typhoon™ 3D Instruction Manual*



**Charge-and-Fly™ Park Flyer**

Wingspan: 39.5" (1000mm)  
Overall Length: 34" (862mm)  
Weight: 26 oz. (740 g)

Motor: ParkZone BL400-15T brushless with gearbox  
Charger: Variable rate DC peak for Ni-MH and Ni-Cd batteries

Radio: 4-Channel FM on 72MHz  
Battery: 9-cell 10.8V 1000mAh Ni-MH

Visit [www.modelflight.com.au](http://www.modelflight.com.au) for more information and spare parts.



# Typhoon 3D Instruction Manual

Congratulations on your purchase of the ParkZone™ Typhoon™3D RTF airplane. Your Typhoon 3D comes with everything needed to get you in the air— all in one box! You only need to attach the wing, horizontal stabilizer, rudder, propeller, and landing gear, as well as charge the flight battery prior to your first flight. In as little as 40 minutes, you can be ready to fly. This means you can spend your time refining your 3D flying, and not your building skills. Your ParkZone Typhoon 3D will allow you to do such maneuvers as harriers, blenders, hovering, knife edges, and more! We at ParkZone are committed to giving you the most enjoyable flight experience you can have. In order to have a safe and successful flight, we ask that you do not fly until you have read these instructions thoroughly.

Your Typhoon comes with a fully proportional 4 channel radio system with full control of throttle, rudder, aileron, and elevator. Your Typhoon 3D also comes with a powerful 400-size brushless motor and ESC, as well as a 9-cell 10.8V 1000mAh flight battery pack and variable rate DC peak charger. Your Typhoon 3D also allows you to add the Thunder Power 2100mAh 3S Li-Po battery pack for even greater power and 3D performance, as well as more flight time.

## Warning

Though your ParkZone Typhoon 3D comes ready to fly, this aircraft is for experienced R/C pilots only and is not a toy! It can cause serious bodily harm and damage to property!

## Advancing your Flying Skills

Once you have begun to fly your Typhoon and are looking for more ideas on maneuvers, visit:

<http://www.horizonhobby.com/Explore/Article.aspx?ArticleID=1022>

<http://www.horizonhobby.com/Explore/Article.aspx?ArticleID=1033>

<http://www.horizonhobby.com/Explore/Article.aspx?ArticleID=1044>

## Step 1

### Transmitter

Your ParkZone Typhoon 3D airplane comes with a fully proportional (Mode 2) 4-channel radio system. In this configuration, the left stick controls throttle and rudder, while the right stick controls elevator and aileron. There is also a dual rates switch on the top right part of the transmitter that will increase/decrease the travel of the control surfaces of the airplane.

1. Insert the included 8 “AA” batteries that are included with the package into the transmitter.
2. Turn switch on to ensure the batteries have been installed correctly. When the batteries are installed correctly, the LED’s on the Tx should glow brightly. When the transmitter makes a repeated “beep” sound, it is time to replace the transmitter batteries.

## Step 2

### Charging the Aircraft Battery

The included variable rate DC peak charger uses unique circuitry that ensures an accurate charge for the 9-cell 1000mAh Ni-MH battery pack every time. It also protects the battery from being over-charged, which can damage the battery pack. The charger constantly monitors the battery pack's charge curve and then automatically switches from fast charge to trickle when the battery is fully charged.

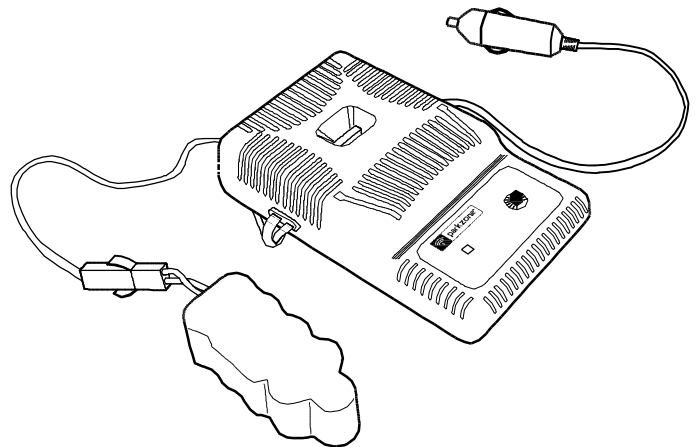

**Important:** Always charge your ParkZone™ 9-cell Ni-MH battery pack shortly before flying. NEVER charge a Li-Po battery pack with the included DC peak charger. Lithium polymer batteries are significantly more volatile than Ni-Cd or Ni-MH batteries used in R/C applications. All manufacturer's instructions and warnings must be followed closely. Mishandling of Li-Po batteries can result in fire.

BATTERY CAPACITY	MAX. CHARGE RATE	CHARGE TIME
1000mAh 10.8V Ni-MH	1.4 amps	40 minutes

### Variable Rate DC Peak Charger Features:

- Variable charge rates from .5–1.8 amps
- Trickle charge
- Uses automobile 12V power outlet
- Charges 5-10 cell Ni-Cd and Ni-MH battery packs
- LED charge indicator

### Charging the 9-cell 10.8V Aircraft Battery

1. Using the dial on the side of the charger, adjust the charge rate to 1.4 amps.
2. Connect the battery pack to the charger.
3. Connect the charger to the 12V power outlet in your automobile. The LED on the charger will continually blink when the charger is fast charging.
4. When the LED glows steadily, the battery is fully charged and the charger has automatically switched to trickle charge. Approximate charge time for a fully discharged battery pack at a charge rate of 1.4 amps is 40 minutes.

**Note:** Never leave the charger and battery unattended during the charge process. While charging, place the battery on a heat-resistant surface and constantly monitor the battery's temperature. If the battery becomes hot at any time during the charge process, discontinue charging immediately. Do not allow children to charge battery packs without adult supervision.

## Step 3

### Installing Landing Gear

1. Slide landing gear into allotted space on fuselage.
2. Fit should be snug, so it will not easily pull out.

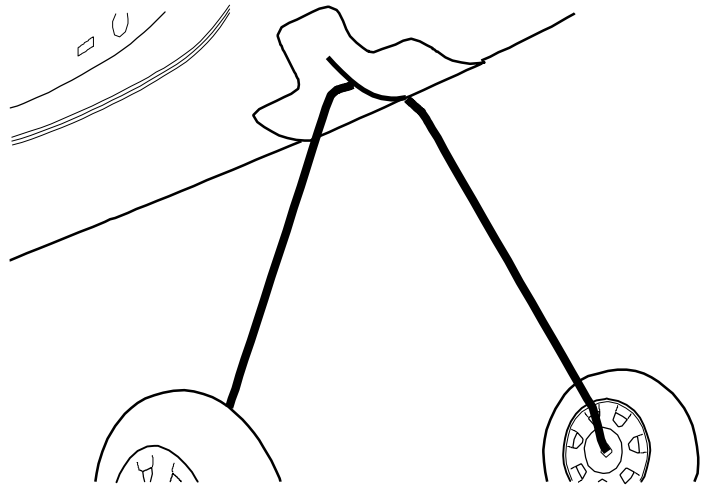

## Step 4

### Attaching the Wing

1. Locate the wing set. Note that the servos are located in the bottom of the wing.
2. Select a wing half and slide in fuse, making sure that you slide aileron servo lead in first (in allotted hole in side of fuse.) Pull aileron lead carefully through fuse in order to allow wing tab and spar to go into their allotted holes. Do the same with the other wing half.
3. Carefully slide wing halves toward each other until the wing tabs overlap.
4. Match up the holes on each tab and secure with included screw.
5. Plug in the aileron connectors into Rx. Left aileron should plug into allotted space of receiver (directly below elevator). Right aileron lead should plug into second space of Rx allotted for aileron.

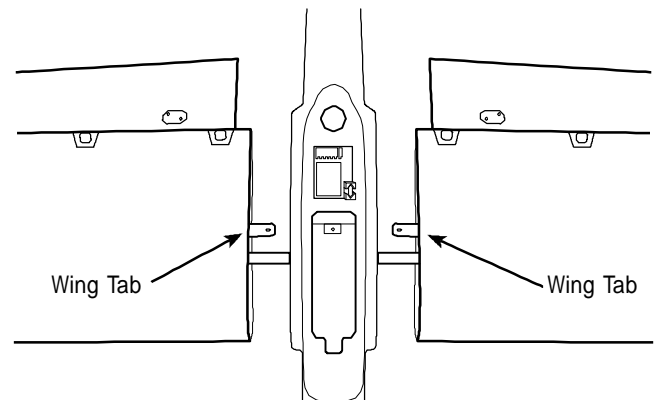

*Always check ailerons prior to flight to make sure they are not reversed!*

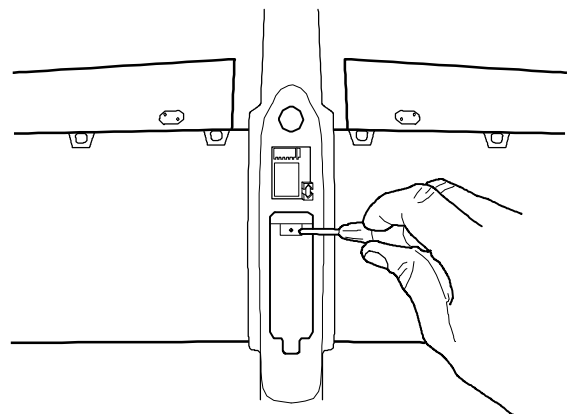
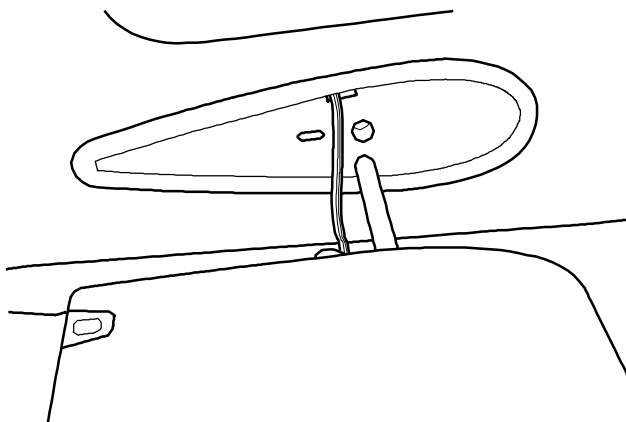

## Step 5

### Attaching the Horizontal Stabilizer and Rudder

1. Locate horizontal stab.
2. Carefully slide horizontal stab into fuselage, making sure control surface horn is on top.
3. Use included strips (4 pieces) of clear tape to secure stab to tail fillet. You should use 1 strip for top and bottom of each side.
4. Locate rudder. Carefully snap tail wheel wire into the clip on bottom of fuse, as shown.
5. Carefully use hobby knife to slowly separate decal from foam only where three hinges are to attach to stab. When decal is slightly separated from the foam, slide hinges between decals and foam of stabilizer. Use the three pins that are supplied to connect rudder to stab, as shown. Do this by pushing pins in carefully.
6. Install keepers on backside to secure pins as shown.
7. Attach rudder and elevator pushrods to respective control horns (outer holes of control horns for both).

*Note: It may be necessary to re-trim control surfaces prior to flight.*

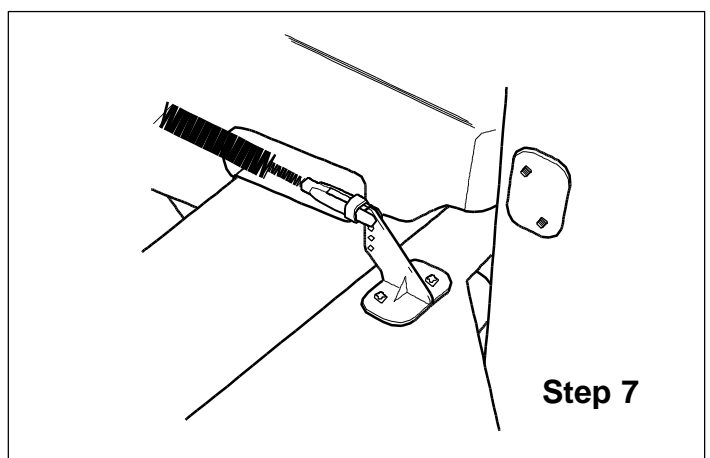
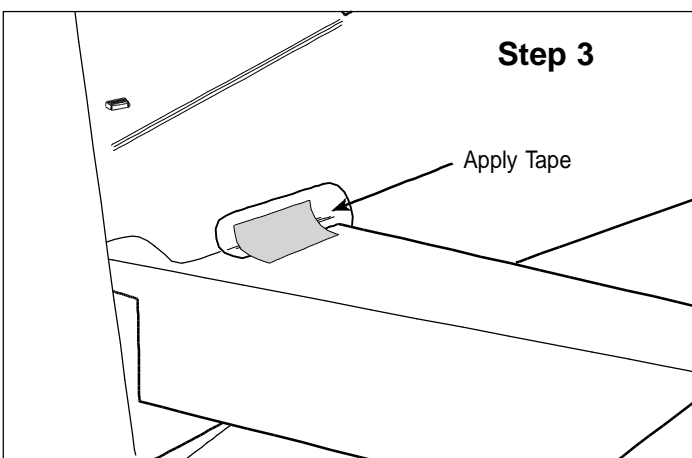
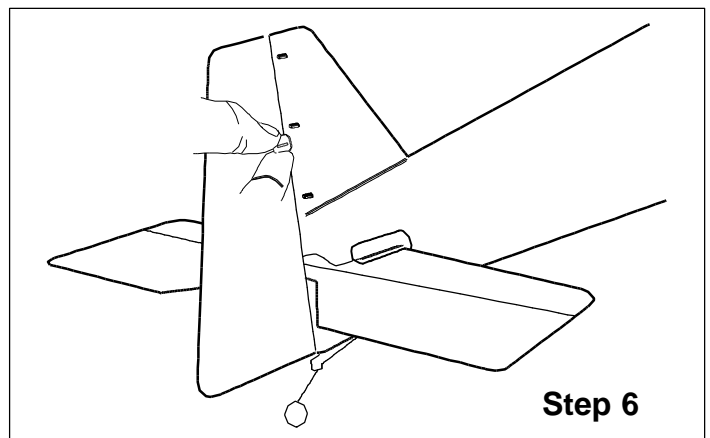
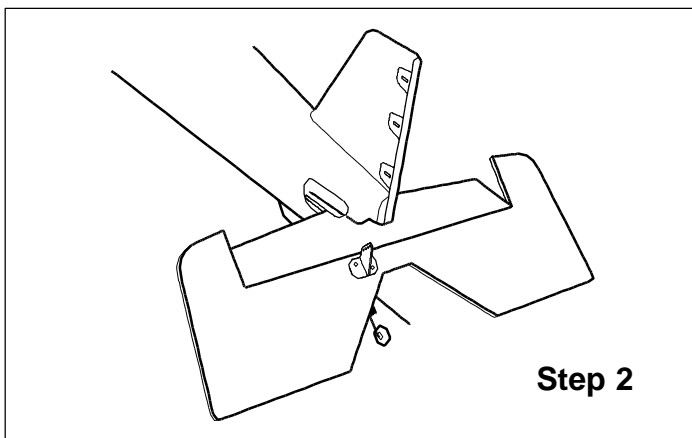
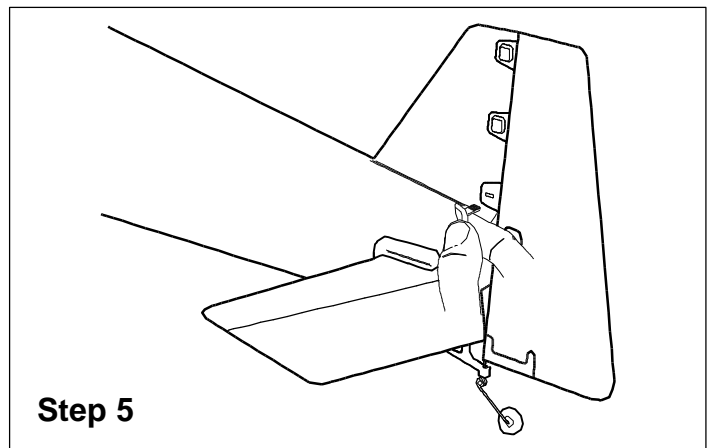
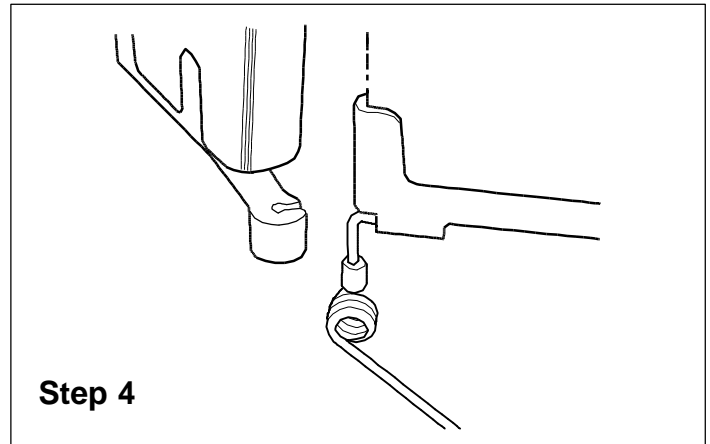

## Step 6

### Installing the Propeller and Spinner

Your Typhoon™3D has two props that are included. You can select the prop that best works with your flying style.

- A. 13.5 x 7 (PKZ1006): This prop is recommended for the first several flights on your plane. This prop will allow your plane to fly a bit slower, but is also the set up for maximum vertical power (especially with the 9-cell Ni-MH pack).
- B. 12 x 8.75 (PKZ1007): This prop will allow you to fly at faster speeds and help with certain aerobatic maneuvers. This propeller is ideal for the Thunder Power 3S 2100mAh Li-Po battery pack.

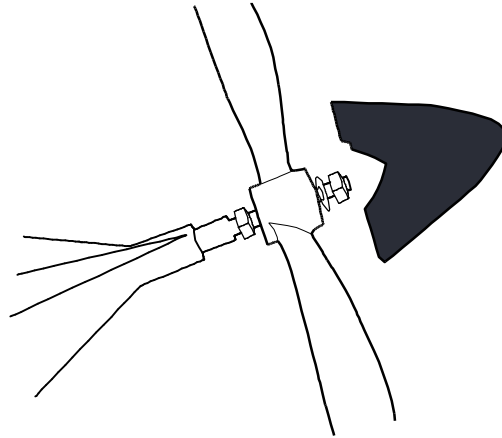

When you have selected the propeller that best works for you, install and secure it making sure not to forget any of the necessary hardware.

1. Slide propeller on. Make sure pitch numbers on prop are visible from front of airplane.
2. Slide washer on first. Next, screw the nut on and tighten securely.
3. Attach spinner.

## Step 7

### Receiver

The following are the channels that are programmed in the receiver:

- Ch. 1: Throttle
- Ch. 2: Elevator
- Ch. 3: Aileron (R)
- Ch. 4: Aileron (L)
- Ch. 4: Rudder
- Ch. 5: Aux1

Make certain you plug in the servo leads to the correct corresponding channel. Always perform a function check prior to flying to ensure this.

### Jumper In

Your Typhoon receiver comes with a jumper installed into the Rx's sixth port (Aux 1). When this jumper is installed, the switch on the top right of the transmitter functions as a dual rates switch, and the Rx has dual aileron ports. You will notice much more travel in the control surfaces in high rate.

### Jumper Out

If you decide to use the radio system in another application, you can remove the jumper. The switch on the Tx will then operate as a toggle for the GEAR channel on the receiver and can be used for an additional channel, such as for up/down function of landing gear. Notice the other channel changes that occur when the jumper is absent.

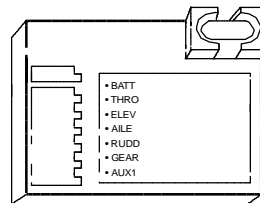

Jumper Out:  
Normal Mode

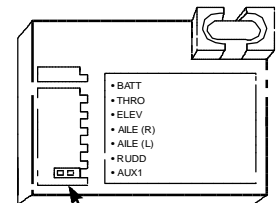

Jumper In:  
Typhoon Mode

## Step 8

### ParkZone 4-Channel Radio System

Your ParkZone™ Typhoon™3D comes with a fully proportional 4-channel radio system (Mode 2). Your Typhoon also comes with industry standard 3-wire servos making the radio system usable in other small electric aircraft if you so choose. As with all Mode 2 style systems, the left gimble operates the throttle and rudder, while the right gimble operates the aileron and elevator.

**Note:** The servo reversing features of this radio system will allow it (if you so choose) to be used in another park flyer application. The servo reversing switches on the Tx should all be set at the top (normal) for the setup with this airplane. If any of the switches are set at the bottom (reverse), the function will be reversed and could put your Typhoon in jeopardy.

### Transmitter Features:

- Fully proportional 4-channel FM radio system with full control of throttle, elevator, aileron, and rudder (Mode 2)
- Dual rates switch (hi and low rates) when in Typhoon Mode
- Proportional trim adjustment
- LED battery voltage indicators
- Neck strap holder
- Charge jack for use with rechargeable Tx batteries
- Servo reversing
- Comfortable ergonomic case design

The stock setup for all of the servo reversing switches on Tx are at the top (normal).

*The following statement applies to the receiver (in U.S.A)*

This device complies with part 15 of the FCC rules. Operation is subject to the following two conditions:

1. This device may not cause harmful interference, and
2. This device must accept any interference received, including interference that may cause undesirable operation.

Changes or modifications not expressly approved by the party responsible for compliance could void the user's authority to operate the equipment.

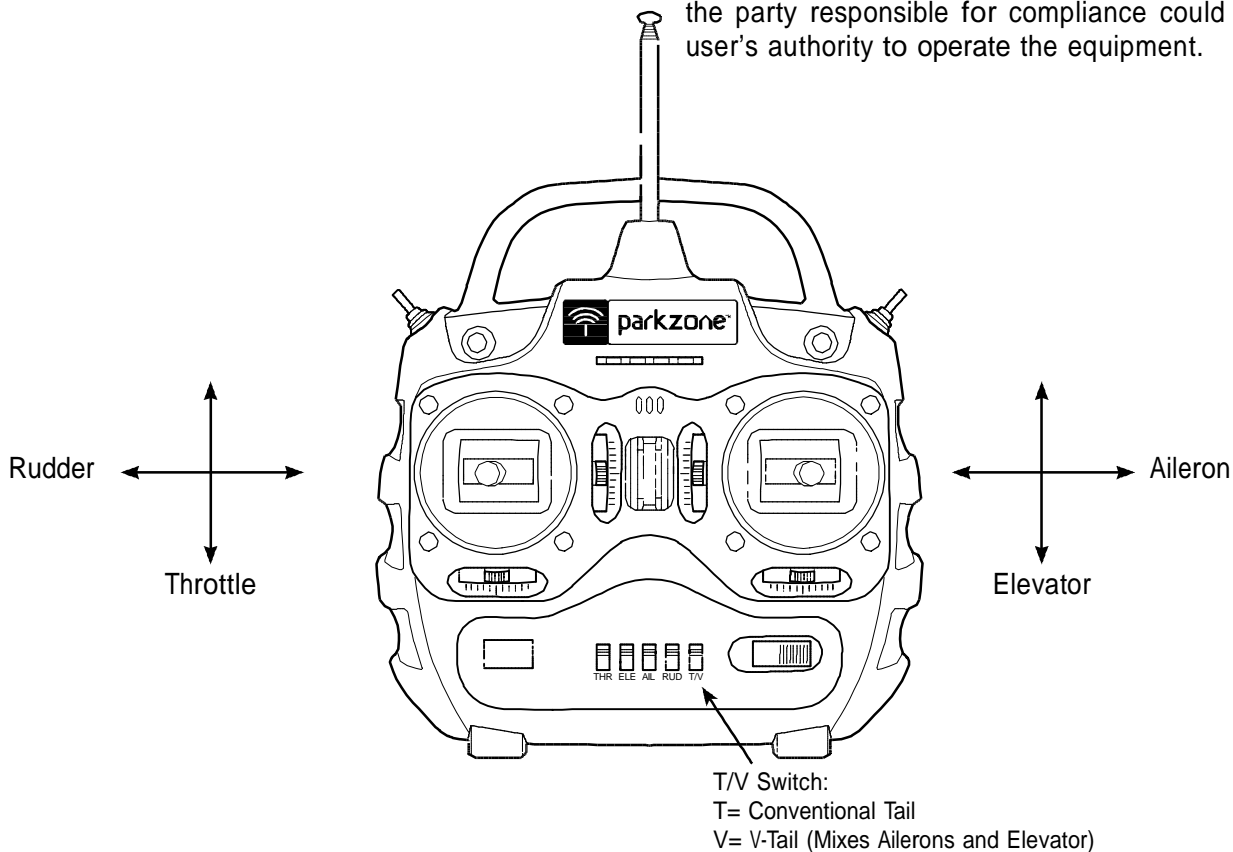

## Step 9

### 20 Amp ESC:

The Typhoon™3D can be powered by either a 9-cell 10.8V 1000mAh Ni-MH or a 3S 11.1V 2100mAh Li-Po battery pack. Using the Thunder Power 3S battery will greatly increase the power, performance, and flight time of your Typhoon 3D.

The ESC comes with the auto-cut voltage set for the 9-cell Ni-MH battery pack. You must reprogram the voltage automatic cut-off if you are planning to fly with the 3S Li-Po battery. Failure to do this will result in permanent damage to your battery pack.

*Reminder: All Li-Po battery packs must be charged by Li-Po specific chargers only! Failure to follow these instructions may result in a fire!*

### Programming Your ESC:

1. To enter the programming mode, the controller must be powered up with the throttle in full position and held there for 5 seconds.
2. When this is done, the ESC will be in the setup mode and will beep three times indicating this.
3. Once in this programming mode, return the throttle to mid-stick within 3 seconds, and the ESC will scroll through the menu.

When in the programming mode, select yes (up) or no (down) as follows:

- Yes: Move throttle stick to full for approximately 1 second (controller will beep once), then return to mid-stick.
- No: Move throttle stick to low throttle for 1 second (controller will beep once), and then return to mid-stick.

### A. Menu Item 1: Voltage Auto Cut-Off

1 beep – auto cut-off

\* Need to act within 5 seconds:

Li-Po – up (see above)

Ni-MH – down (stock setting)

After the setting of this parameter, the controller will wait approximately 3 seconds before moving to next menu item.

### B. Menu Item 2: Brake Setting

2 beeps – brake setting

\* Need to act within 5 seconds:

Brake off – up (stock setting)

Brake on – down

### C. Menu Item 3: Motor Timing

3 beeps – motor timing

\* Need to act within 5 seconds:

Outrunner (and 4-pole or greater motors) – up

Inrunner (2-pole motors) – down (stock setting)

After setting the desired parameters, simply power down the ESC and then rearm the controller.

### Motor Arming:

The ESC will not arm the motor until the throttle stick is moved to low throttle and held there for 1 second or more. Three consecutive beeps will indicate this.

## Step 10

### Range Checking your Radio System

After you have finished the final assembly, it is time to range check the radio system within the Typhoon™ 3D.

#### Prior to each flying session:

- Make sure that no one around that may be flying, or is getting prepared to fly, is on the same channel that you are on. After this is confirmed, turn on transmitter with antenna down. Next, turn on receiver (switch on the plane). With airplane on the ground and motor running, you should walk away approximately 100 ft. and still have full control of all functions. If this is not the case, do not fly! Call Product Support at 1-877-504-0233.

- Always make sure that all controls are functioning per the Tx input that you are giving. This includes, ailerons, rudder, elevator, and throttle.
- Always make sure that you have fully-charged transmitter batteries.

**Always remove the flight battery from the airplane when you are done flying, or when you are on the way to the flying field.** The switch on the fuselage is for short-term use only (when you are at the field). Leaving the battery plugged in the airplane for an extended time could cause permanent damage to your battery (especially if you are using a Li-Po battery).

## Step 11

### Flying

Always choose a wide-open space to fly your ParkZone™ Typhoon 3D. It is ideal for you to fly at an AMA sanctioned flying field. If you are not flying at an AMA approved sight, always avoid flying near houses, trees, wires, and buildings. You should also be careful to avoid flying in areas where there are many people, such as busy parks or school yards. Always follow local ordinances.

#### Prior to each flight:

- Always make sure that your Typhoon 3D is properly trimmed. From time to time, it may be necessary to re-trim your airplane. Simply turn on the radio system, with the flight battery plugged into the battery port and check all control surfaces. Most trim changes should be able to be made using the trim levers on the transmitter. Greater changes will need to be made by removing the clevis from the control horn and turning in on the pushrod in the appropriate direction.
- Always make sure the receiver, ESC, and battery are properly secured.
- Always verify the propeller is on securely.
- Always ensure the servo reversing switches on the Tx are set correctly.
- Verify that the propeller is fitted in the correct direction and is attached securely.

- Always verify the dual rates switch is set at the level where you plan on flying. We recommend LOW rates for your initial flights. The Typhoon 3D is VERY maneuverable on high rates and requires a lot of experience to handle properly

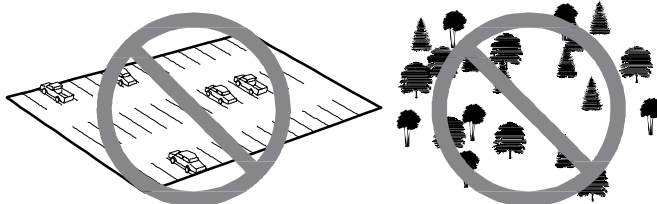
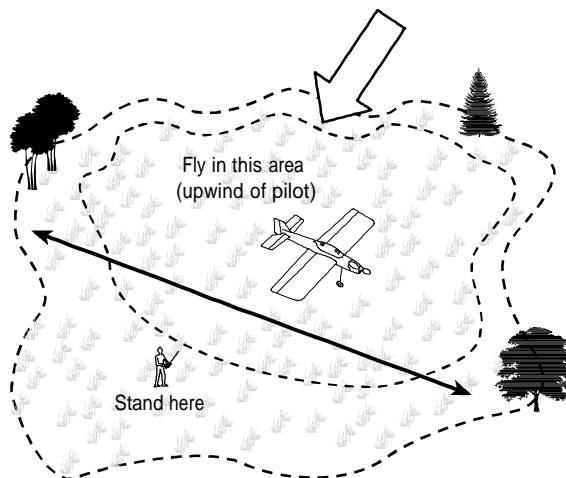

# Warranty and Follow-Up Procedures

Horizon Hobby, Inc. guarantees this merchandise to be free from defects in material and workmanship at the date of purchase. This warranty does not cover any component parts, or damage by use or modification. In no case shall Horizon Hobby's liability exceed the original purchase cost of this item. Further, Horizon Hobby reserves the right to change or modify this warranty without notice.

This warranty covers only those products purchased from an authorized Horizon Hobby dealer. Third party transactions are not covered by this warranty. Proof of purchase is required for warranty claims. Due to the nature and operation of your Typhoon™3D, the warranty does not extend beyond the initial pre-use testing. Carefully check the parts and operation BEFORE your first use. If you discover defects during pre-use testing, please call our Product Support Team toll-free at 1-877-504-0233 for technical support.

In that Horizon Hobby has no control over the final assembly, or material used for final assembly, no liability shall be assumed nor accepted for any damage resulting from use by the user of the final user-assembled product. By the act of using the user-assembled product, the user accepts all resulting liability. Please note that once assembly has been started, you must contact Horizon Hobby, Inc. directly regarding any warranty questions. Please do not contact your local hobby shop regarding warranty issues. This will enable Horizon to better answer your questions and service you in the event you need warranty assistance.

Horizon Hobby, Inc. reserves the right to inspect any and all equipment involved in a warranty claim. Repair or replacement decisions are at the sole discretion of Horizon Hobby, Inc. Collateral damage is not covered under this warranty. If you, as the buyer or owner, are not prepared to accept the liability associated with the use of this product, you are advised to return it immediately in new and unused condition to the place of purchase.

If you have any questions concerning your ParkZone™ Typhoon 3D, please contact our Product Support staff toll-free at 1-877-504-0233.

If your plane requires inspection, please follow these steps in order to return it to us:

1. Call our Product Support team for return authorization.

2. Use the "Service and Repair Checklist" from [www.horizonhobby.com](http://www.horizonhobby.com) under the support tab or write a detailed letter that includes:
  - Your name, address, home phone number, and daytime phone number;
  - A list of the products being shipped for inspection or repair;
  - A detailed account of the type of problems you are incurring; and
  - The payment method you wish to use for any purchases or charges, including credit card type, number, expiration date and your name as it appears on the card.
3. Submit proof of purchase, including purchase date and retailer information.
4. Make sure that the batteries are unplugged and removed. Please use packing material to separate them from your Typhoon 3D.
5. Pack all components and accessories in the original box, and then pack it in a sturdy box with packing materials for safe shipping.
6. For inspection and/or repair, please ship your product to:

Horizon Service Center  
Attn: ParkZone Department  
4105 Fieldstone Road  
Champaign, IL 61822

We suggest you ship your Typhoon 3D via a carrier that provides package tracking and/or signature required. Horizon Hobby, Inc. is only responsible for product once it arrives and is accepted at our facility. Most carriers require optional insurance to cover damage or loss in transit, so please consider this when shipping merchandise.

## Warranty Service

Providing all warranty conditions have been met, defective parts will be repaired or replaced without charge and shipped to you via ground freight prepaid. Again, crash or other collateral damage or expense is not covered under warranty. Proof of purchase date and location is required for all warranty service.

## Non-Warranty Service

If our inspection finds the repair cost exceeds \$50 or more than 50% of the value of your product, we will contact you with a repair estimate and advise you of the available options.

If you have any warranty questions that have not been answered by the information listed above, please call our Product Support staff at 1-877-504-0233.

## Replacement Parts

Make sure that you keep your Typhoon™3D flying! Replacement parts are available at your local hobby shop or from Horizon Hobby ([www.horizonhobby.com](http://www.horizonhobby.com)). Please try your local hobby shop first. By supporting them, they will be there when you need them!

Item #:	Description:	Retail:
PKZ1006	13.5 x 7 Propeller: Typhoon 3D	\$3.49
PKZ1007	12 x 8.75 Propeller: Typhoon 3D (Aerobatic)	\$3.49
PKZ4102	Decal Set: Typhoon 3D	\$4.99
PKZ4104	Prop Shaft w/Hardware: Typhoon 3D	\$2.29
PKZ4107	Spinner: Typhoon 3D	\$2.29
PKZ4113	Canopy: Typhoon 3D	\$3.29
PKZ4114	Firewall w/Screws: Typhoon 3D	\$2.19
PKZ4115	Instruction Manual: Typhoon 3D	\$.99
PKZ4116	Brushless Motor w/Pinion: Typhoon 3D	\$46.99
PKZ4117	Brushless Controller (20 Amp): Typhoon 3D	\$49.99
PKZ4120	Wing Set: Typhoon 3D	\$21.99
PKZ4121	Control Horns w/Hardware: Typhoon 3D	\$4.99
PKZ4122	Pushrod and Clevis Set: Typhoon 3D	\$2.59
PKZ4123	Ailerons (2) w/Parts: Typhoon 3D	\$9.99
PKZ4124	Vertical Tail w/Parts: Typhoon 3D	\$9.99
PKZ4125	Horizontal Tail w/Parts: Typhoon 3D	\$9.99
PKZ4126	Cowl: Typhoon 3D	\$2.49
PKZ4128	Gearbox w/Pinion: Typhoon 3D	\$8.99
PKZ4130	Mini Servo (3W) w/Arms: Typhoon 3D	\$12.99
PKZ1131	Servo Gear w/Accessories	\$2.49
PKZ4141	4-Channel Tx: CH 17, 72.130: Typhoon 3D	\$32.99
PKZ4142	4-Channel Tx: CH 19, 72.170: Typhoon 3D	\$32.99
PKZ4143	4-Channel Tx: CH 21, 72.210: Typhoon 3D	\$32.99
PKZ4144	4-Channel Tx: CH 50, 72.790: Typhoon 3D	\$32.99
PKZ4145	4-Channel Tx: CH 52, 72.830: Typhoon 3D	\$32.99
PKZ4146	4-Channel Tx: CH 54, 72.870: Typhoon 3D	\$32.99
PKZ4151	Rx: CH 17, 72.130: Typhoon 3D	\$28.99
PKZ4152	Rx: CH 19, 72.170: Typhoon 3D	\$28.99
PKZ4153	Rx: CH 21, 72.210: Typhoon 3D	\$28.99
PKZ4154	Rx: CH 50, 72.790: Typhoon 3D	\$28.99
PKZ4155	Rx: CH 52, 72.830: Typhoon 3D	\$28.99
PKZ4156	Rx: CH 54, 72.870: Typhoon 3D	\$28.99
PKZ4167	Bare Fuselage: Typhoon 3D	\$28.99
PKZ1519	DC Peak Charger	\$29.99
PKZ1027	10.8V 9-cell battery: P-51D, Typhoon 3D	\$32.99

### Option Parts

THP21003S	Thunder Power 3S 2100mAh Li-Po Battery Pack	\$79.99
EFLC3005	Celectra 1- to 3-cell Li-Po Charger	\$53.99
HBZ1083	Large Battery Connector	\$.79
HBZ1081	Charger Connector w/Wire	\$1.00

PKZ4115



Visit [www.modelflight.com.au](http://www.modelflight.com.au) for more information and spare parts.