

The R/Cer's Partner

CG-325

MULTI CHARGE-A-MATIC INSTRUCTION MANUAL

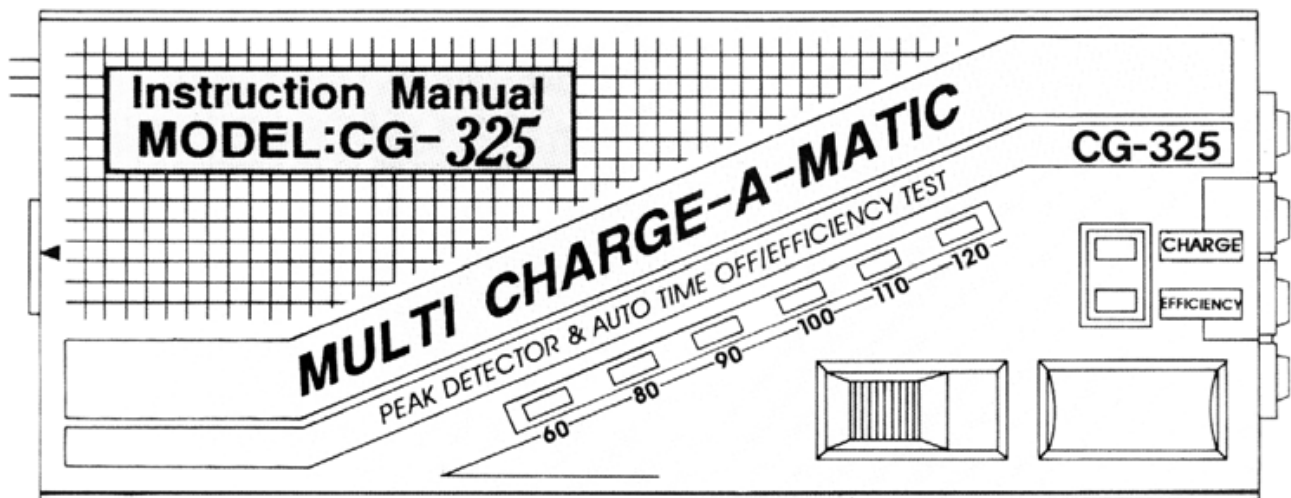

hitec

INSTRUCTION

Congratulations and thank you for your investment in the Multi Charge-A-Matic charger and batter tester for rechargeable battery packs. The Multi Charge-A-Matic features the very latest in battery charging and discharging technology for years of trouble free service. Whether you drive a race car, Fly an electric aircraft, or pilot fast electric boats, the Multi Charge-A-Matic will suit your needs for rapidly recharging your batteries.

MAJOR FEATURES

- Peak detection type auto charging
- Automatic trickle charge mode
- Multi-charger for transmitter and receiver packs, as well as racing packs, ranging from 4.8V through 10.8V, and having capacities from 270mA through 1800mA.
- Battery pack discharging capability
- Battery pack capacity testing

GENERAL DESCRIPTION

The Multi Charge-A-Matic fast charger and battery capacity tester features a peak detection type charging circuit, allowing rapid charging of battery packs without constant monitoring. It automatically provides a full charge to the pack and then switches to a safe trickle charge on completion. An audio alarm sounds when peak charging is completed and trickle charging begins. The charger is capable of providing from 0.9A up to 4.5A of charging power to a pack, and can be used from any 12Vdc power source. The Multi Charge-A-Matic can handle small 4.8V, 270mA receiver packs, as well as large 9 cell 1800mA packs.

The battery efficiency feature of the Multi Charge-A-Matic can not only discharge a pack when desired, but can also provide precision battery pack capacity readings. This is especially desirable when selecting the beat racing pack to use in racing, or to determine if a battery pack is faulty and in need of replacement. Using the discharge feature also prevents the possibility of battery memory effects.

SWITCHES AND INDICATORS

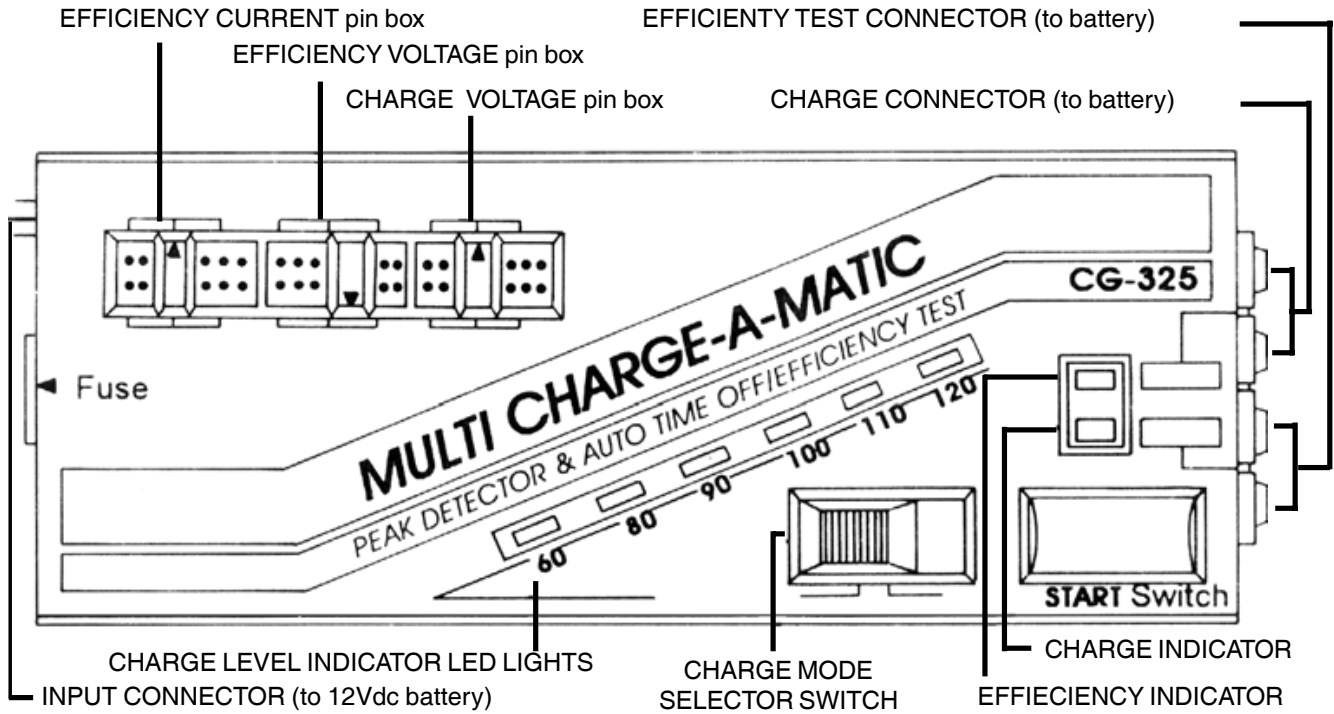

OPERATION

BATTERY CHARGING SECTION

The battery charger function of the Multi Charge-A-Matic utilizes peak detection type circuitry to determine when the battery has reached full charge and automatically stops the charge cycle. On completion, the unit falls into a trickle charge mode to maintain the fully charged condition of the pack. The trickle charge rate is variable, dependent on the original charging rate used for charging, with a minimum rate of 50mA and a maximum of 200mA. The user can select a charge current from 0.9A to a maximum of 4.5A using the selector tabs on the face of the charger. An internal power converter allows peak voltage rates above 12V when necessary. Normally, most chargers cannot charge packs exceeding 8 cells, or 9.6V, as incoming power source is only 12V and peak voltages easily exceed this input voltage. Our new technique allows the Multi Charge-A-Matic to boost the incoming source voltage, enabling the charger to fully charge up to 9 cells. You can now safely charge your transmitter packs in the field. The Multi Charge-A-Matic also features several user protection items for safety and peace of mind. A built in timer circuit prevents and charge from exceeding 50 minutes in length. Should a malfunction occur in the charging circuit, the timer will cut off the current after 50 minutes. The Multi Charge-A-Matic is also fuse protected to prevent damage to the unit in the case of a reversed polarity hookup.

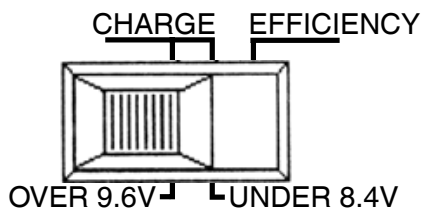

1. To begin charging with the Multi Charge-A-Matic, locate the CHARGE/EFFICIENCY selector switch on the front of the charger. Note that this is a three position switch, with the left position for charging packs of 9.6V or more, the center position for 4.8V to 8.4V, and the right position for testing a battery capacity or discharging a pack. At this time, select the correct voltage range for the pack you are charging with the CHARGE/EFFICIENCY switch.

NOTE When charging packs of 9.6V or more, the charge current should be either 0.9A or 1.6A, regardless of battery capacity. The internal booster cannot handle currents of greater than 2.6A and damage may result.

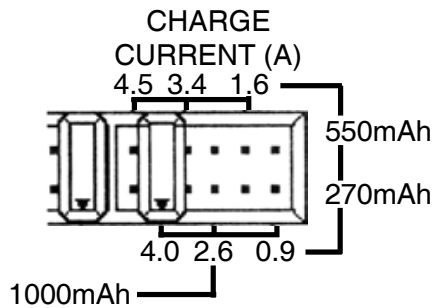

2. Locate the CHARGE CURRENT pin box and select the charge current desired for charging by placing the selector tab over the pins corresponding to the “A” rate desired. For example, if you wish to charge at 4.0A, simply plug the selector tab over the pins for 4.0A. Below is a reference table for recommended charging rates for battery packs.

Current \ Capacity	0.9A	1.6A	2.6A	3.4A	4.0A	4.5A
270mA	○					
550	○	○				
800		○	○			
1000			○	○		
1200			○	○	○	○
1400				○	○	○
1800				○	○	○

These are recommendations only, and using a lower charge current will not harm the battery pack. However, not that using charge rates greater than what is recommended could damage the battery packs in the long run, so please use caution. Please note again that packs with voltage rates over 9.6V may use charging rates of 0.9A to 1.6A only.

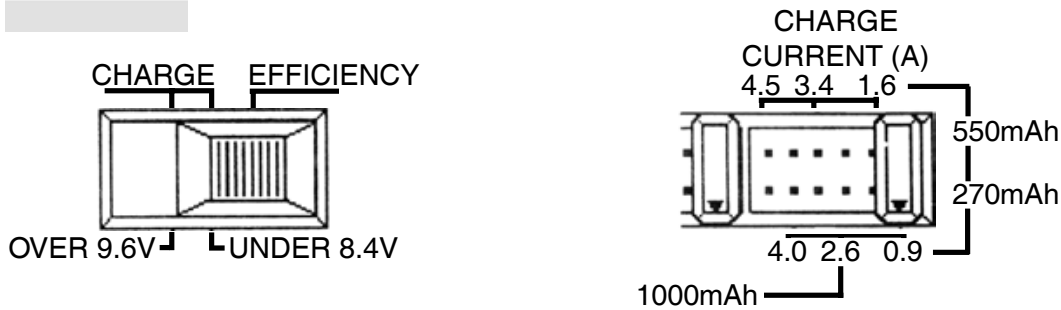

When charging packs of 9.6V or higher, move the CHARGE/EFFICIENCY selector switch to the far left position. Now, select the CHARGE CURRENT of 0.9A or 1.6A only. Begin charging by depressing the START button for at least 5 seconds. Again, the CHARGE indicator light will tell you that the battery is receiving a charge.

2. Connect the battery being charged to the Multi Charge-A-Matic with the proper connector, and into the CHARGE connector blocks on the right side of the unit. Observe using the correct polarity, with the RED(+) wire connected to the RED block, and BLACK(-) wire connected to the BLACK connector block. Now, connect the input power wires to your source of power. We have provided alligator type connectors for your convenience. At this time, the unit will automatically enter the trickle charge mode if the battery pack is connected. The CHARGE indicator light will also flash slowly at this time.

3. To begin charging, depress the START button and hold it down for at least 5 seconds. When the charging cycle has started, the CHARGE indicator light will come on. When charging has been completed by the unit, an audio signal will sound (melody sound) and the charger will again return to trickle charge mode. You may stop the audio alarm by quickly pressing on the START button. If you wish to reapek the pack for racing, repeat the above steps for charging. You may also simply trickle charge a pack by connecting the pack to the charger and not depressing the START button.

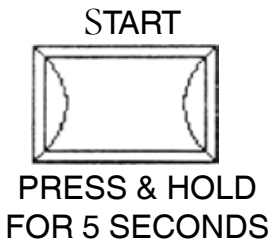

FUSES The Multi Charge-A-Matic is fuse protected to prevent damage to the unit in case the incorrect polarity is connected to the charger. Should the charger fail to operate, check the fuse first, located on the left side of the charger. If necessary, replace the fuse with a standard automotive type spade fuse of 7.5A capacity only. Do not use a fuse of higher capacity. This will remove any polarity protection the fuse affords to the charger, and may result in damage to the charger.

BATTERY EFFICIENCY TESTING AND DISCHARGING

The battery efficiency feature allows the user to test battery packs to determine if the pack provides full performance, or may be faulty and in need of replacement. The discharge feature allows a safe method of discharging a pack in between races or for extended storage time. Battery life can be extended by cycling the pack regularly, as well as preventing the possible effects of battery memory.

DISCHARGING BATTERIES

1. To begin discharging a battery pack, place the CHARGE/EFFICIENCY selector switch into the extreme right position. Next, select the discharge rate from the EFFICIENCY/CURRENT pin box.

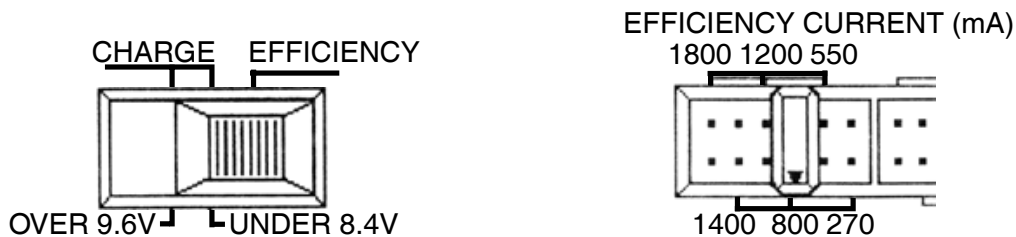

- Select a pin position which matches the capacity of the pack you are discharging and place the selector tab onto the selected pin.
2. Connect the battery pack to the Multi Charge-A-Matic using the EFFICIENCY connector blocks on the right side of the unit. Observe the wires for the correct polarity, i.e. Red (+) wire to Red and Black (-) wire to Black.
 3. Depress the START button once and the discharge cycle will begin. The EFFICIENCY indicator light will begin flashing during the discharge. When the pack reaches a predetermined discharged state, the unit will stop discharging and an audio signal will be heard. You may now remove the pack.

Note The charger will get quite warm when discharging a battery pack or during efficiency testing. Keep the unit in a cool area when discharging batteries. A fan will assist in keeping the unit cool.

EFFICIENCY TESTING BATTERIES

To properly determine the capacity of a battery pack, you must use a fully charged battery pack, using the CHARGING instructions above. Use this charger for performing the charge cycle, to maintain a uniform discharge curve. Other chargers may not fully charge a battery pack, which will result in false testing.

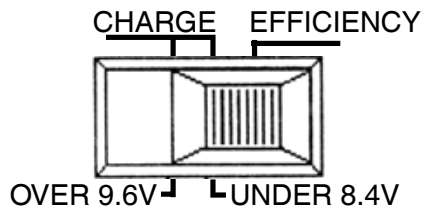

1. To begin efficiency testing, connect the battery to the EFFICIENCY connector blocks, select the EFFICIENCY position on the CHARGE/EFFICIENCY selector switch, and then select the correct EFFICIENCY VOLTAGE and EFFICIENCY CURRENT in the pin boxes with the selector tabs.

2. Press the START button to begin the efficiency test. The EFFICIENCY indicator light will blink slowly when the testing is underway. As the testing progresses, the LED indicator lights will begin lighting across the front panel of the Multi Charge-A-Matic.
3. When the battery has been fully discharged to a predetermined level, an audio alarm will sound and the EFFICIENCY indicator light will stop blinking. To stop the audio alarm, you may tap the START button quickly.
4. The battery capacity is shown on the EFFICIENCY LED indicator lights on the front panel. The light with the highest percentage indicates the capacity of the pack in relation to the EFFICIENCY CURRENT you have selected.

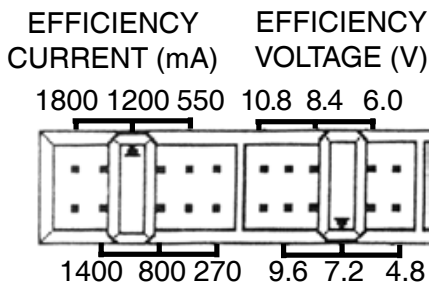

For example, if you are testing a 1200mA 6 cell pack (7.2V), and you have selected an efficiency current of 1200mA, then the pack would be of proper capacity if the efficiency indicator of 100% was lit after the test cycle. The same pack would be very good if the efficiency was up to 120%, but would need replacement if the capacity only reached 80%.

Note The charger will get quite warm when performing the efficiency test. Keep the charger in a cool area during efficiency testing. A fan will assist in cooling.

It is important to use the correct Efficiency Current pins when performing the Efficiency test. The use of an incorrect Efficiency Current will result in false efficiency readings. Should you have a battery pack which does not exactly match the Efficiency Current pins of the Multi Charge-A-Matic, you can still calculate the correct efficiency of the pack. Select the closest Efficiency Current pin on the charger and conduct the Efficiency test. When the test is completed, read the final indicator for the pack. Using a simple formula, You can calculate the capacity of the pack. Suppose you have a 500mA pack, with the closet pin 550mA.



After testing, you find that you have a final reading of 110%. Use the formula below to calculate the capacity.

$\frac{\text{Selected current (550mA)}}{\text{Current of Battery Pack (500mA)}} \times \text{Efficiency Reading (110\%)} \\ (550\text{mA} / 500\text{mA}) \times 110\% = \text{Approximately 120\%}$
--

Below is an Efficiency Table which shows the capacity readings as derived from the Multi Charge-A-Matic. Use this chart to further understand the efficiency readings from the indicator lights of the charger.

Indicator	Charge capacity	Color
No light	under 59%	X
60	60-79%	Red
80	80-89%	Red
90	90-99%	Red
100	100-109%	Green
110	110-119%	Green
120	over 120%	Green

Cautions

1. Always check all connectors and wires for a complete and firm fit to the charger and the battery for best results.
2. Do not use any wire longer than 8 inches for charging or checking the efficiency of the battery pack.
3. Do not use the Efficiency test feature continuously without cooling in order to prevent overheating.
4. When charging packs rated at 9.6V or above, the charger current should be 0.9A or 1.6A.

Accessories

Your Hitec Multi Charge-A-Matic comes with one spare spade fuse, one spare selector tab, one battery connector with Tamiya style plug, and a cigarette lighter style connector for use with the cigarette plug of an automobile.

