

Futaba®

DIGITAL PROPORTIONAL RADIO CONTROL

INSTRUCTION MANUAL

FP-5UAP PCM 1024 SYSTEM
 FP-5UAF FM SYSTEM
 FP-5UA AM SYSTEM

FUTABA CORPORATION

D60466

FOR AIRCRAFT, PCM/FM/AM 5 CHANNELS SYSTEM.

Thank you for purchasing a Futaba digital proportional radio control set.

Please read this manual carefully before using your set.

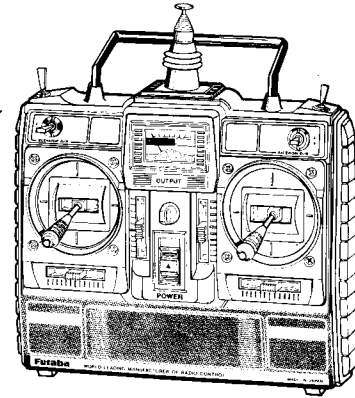

1 FEATURES OF FP-5UAP/FP-5UAF/FP-5UA

- High resolution and fast response PCM1024 system.--- (FP-5UAP)
- Aileron and Elevator D/R (dual rate).
- ATV (adjustable travel volume) for each channel. (except CH5)
- ATL (adjustable throttle limiter) for throttle.
- Servo reversing switch for each channel.
- F/S (fail safe), B-F/S (battery fail safe)---(FP-5UAP)
- PCM/PPM selectable.---(FP-5UAP)
- Trainer system. (Trainer cable optional)
- RF module system.
- Stick spring tension can be adjusted.
- Nonslip adjustable stick lever head.
- Neck strap bracket.
- Easy to read square level meter. (transmitter battery voltage/ RF indicator)
- Rugged low-profile servo.---(FP-S148, FP-S3001)

2 SET CONTENTS AND RATINGS

(Specifications are subject to change without prior notice.)

	FP-5UAP	FP-5UAF	FP-5UA
Transmitter	FP-T5UAP	FP-T5UAF	FP-T5UA
RF module	FP-TP-FM		FP-TP-AM
Receiver	FP-R129DP or FP-R137GP	FP-R128DF or FP-R115F	FP-R117H
Servo	FP-S148 (x4) or FP-S3001 (x3)		
Battery & Charger	Nicd battery system (<ul style="list-style-type: none"> • Transmitter battery NT-8LP • Receiver battery NR-4J • Charger FBC series Pinlight battery (<ul style="list-style-type: none"> • Transmitter battery holder • Receiver battery holder 		
Crystal	• FM crystal set (Transmitter and Receiver) However the crystal type for dual conversion receiver is the following type. (R129DP, R128DF) 72 MHz Band ... (stated on the tab) TYPE 72-10 35 MHz Band ... TYPE 35-10		• AM crystal set (Transmitter and Receiver)
Others	<ul style="list-style-type: none"> • Switch • Extension cord • Spare horn • Others 		

Transmitter (FP-T5UAP/T5UAF/T5UA)

2 sticks 5 channels transmitter	
Transmitting frequency band	: 72, 50, 41, 40, 36, 35 or 29 MHz
Modulation	: FM-PCM/PPM selectable(T5UAP), FM(T5UAF), AM(T5UA)
Power requirement	: 9.6V Nicd battery pack or penlight battery x 8 (12V)
Current drain	: 200 mA

Receiver (FP-R129DP/R137GP/R128DF/R117H/R115F)

Receiving frequency band	: 72, 50, 41, 40, 36, 35 or 29 MHz
Intermediate frequency	: 1st IF 10.7 MHz, 2nd IF 455 kHz (R129DP/R128DF) 455 kHz (R137GP/R117H/R115F)
Power requirement	: 4.8V Nicd battery pack (shared with servo)
Current drain	: 35 mA (R129DP), 25 mA (R137GP), 26 mA (R128DF), 18 mA (R117H) 22 mA (R115F)
Dimensions and weight	: 63.0 x 37.8 x 24.1 mm, 45g (R129DP) 57 x 42 x 24 mm, 43.5g (R137GP) 63.8 x 35.4 x 20.3 mm, 40g (R128DF) 35.2 x 61.7 x 20.3 mm, 32g (R117H) 33.4 x 50.4 x 20.5 mm, 29.5g (R115F) (excluding protruding parts)
Receiving range	: 500m on the ground, 1000m in the air (range differs with the surroundings)

Servo (FP-S148/S3001)

Control system	: + pulse width control
Operating angle	: Rotary system, one side 45° or greater (including trim)
Power requirement	: 4.8V or 6.0V (shared with receiver)
Current drain	: 8 mA at 6V (at idle)
Output torque	: 3 kg/cm
Operating speed	: 0.22 sec/60°
Dimensions	: 40.4 x 19.8 x 36 mm
Weight	: 44.4g (S148), 45.1g (S3001)

Nicd battery (NT-8LP/NR-4J)

Voltage	: 9.6V (NT-8LP), 4.8V (NR-4J)
Capacity	: 500 mAh
Dimensions	: 51 x 58 x 15 mm (NR-4J)
Weight	: 95g (NR-4J)

3 BEFORE USING

Nicad battery system

■ Charging the transmitter and receiver Nicad battery

Remove the charging cap and connect the charger.

- Use the special Futaba charger.
- The charging time is 15 hours.

[However when the battery was not used for some time, charge and discharge it 2-3 times. Otherwise, the battery will not be charged even after the specified charging time.]

A fully-charged transmitter battery can be used for about 10 flights of 10 minutes each. The airborne NR-4J Nicad battery pack can be used for about 8 flights when 4 servos are used.

Notes: (FBC-8B)

- 1) First, connect to TX Nicad and red lamp goes on.
- 2) Then, connect to RX Nicad After connecting, LED changes color from red to greenish red (orange) which indicates that both TX and RX Nicads are being charged.
- 3) In case of separate charging, LED color will be:
RX Nicad - Green
TX Nicad - Red

Penlight battery system

■ Loading the transmitter battery. (Penlight battery x 8)

- 1 Remove the battery cover.

- 2 Load the Battery.

*Load the battery while paying careful attention to the polarity.

■ Receiver and servos connections

Antenna wire

PCM receiver
FP-R129DP, FP-R137GP
FM receiver FP-R128DF or
AM receiver FP-R117H

CH5 Landing gear servo

CH4 Rudder servo

CH3 Throttle servo

CH2 Elevator servo

CH1 Aileron servo

Extension cord

Receiver switch

Receiver switch

Charging jack

Nicad battery pack NR-4J

Battery holder

Pay careful attention to the polarity of the connector.

Receiver connector arrangement

FP-R137GP	FP-R129DP	FP-R128DF	FP-R117H	FP-R115F

PRECAUTIONS

- Connect the receiver, servos, switches and battery as shown in the figure. Extend the transmitter and receiver antennas to their full length.
- Turn on the transmitter power switch, then turn on the receiver power switch.
The servos will go to their neutral position. Move the transmitter sticks one at a time to check that each servo follows its control stick movement.
- Connect the pushrods to the servos and check that the direction of travel of each servo matches the direction of movement of its control stick. If a servo does not move in the proper direction, switch its direction with the servo reversing function.
- Operate each servo horn over its full stroke and check that the pushrod does not bind or is not too loose. Unreasonable force applied to the servo horn will adversely affect the servo and drain the battery pack very quickly. Make the travel of each control mechanism somewhat larger than the full stroke (including trim) of the servo horn. Adjust the servo horns so that they move smoothly even when the trim lever and stick are operated simultaneously in the same direction.
- Be alert for noise.
This set is noise-resistant, but not completely immune to noise. The use of noiseless parts is recommended.
- When installing the switch harness, cut a rectangular hole slightly larger than the full stroke of the switch and install the switch so that it moves smoothly from ON to OFF. Also do this when the switch is installed inside the fuselage and is

- turned on and off from the outside with a piece of wire. Install the switch where it will not be exposed to engine oil or dust and dirt.
- Although the antenna appears to be too long, do not cut it or fold it back.
- Install the servos securely. Tighten the mounting screws until the rubber damper is crushed slightly. If the screws are too tight, the cushioning effect will be adversely effected.
- The crystal can be changed from the outside of the receiver case. Always use the Futaba transmitter/receiver matched crystal set to change the band.
- The FP-R129-DP and FP-R128DF are a dual conversion receiver. This receiver requires a special crystal so please order the correct crystal set.
- Spare servo horns are supplied. Use them as needed.
- Use extension cords matched to the model.
- Wrap the receiver in sponge rubber. Place it inside a waterproof plastic bag and secure the end of the bag with a rubber band. Do the same with the airborne battery pack.
- Use the rubber bands wrapped around the receiver to hold the servo and switch leads.
- After installation and checking are complete, perform a range check by collapsing the transmitter antenna and extending the receiver antenna to its full length and operating the transmitter from a distance of 20 to 30 meters from the receiver. The servos should operate normally at this distance.
* Differs with the weather and surroundings.

■ SERVO HORN MOUNTING SCREW PRECAUTIONS

Servo horn screws			
Horn mounting screw size	Applicable servo	Type	Dimensions (m/m)
2.6x6	S133, S143 series	B	5.7
	S129 series	A	7.9
	S130 series, S9101, S5101	A	7.9
2.6x8	S128 series	B	11.9
	S132 series	B	7.3
	S135 series, S9601	B	8.7
	S138 series	B	9.9
	S148 series	B	10.5
2.6x10	S131S series, S9201, S9301	A	9.0
	S9401	A	9.0
	S136G	A	9.0
2.6x12	S134 series, S3301	A	11.3

Waterproof type A

Non-waterproof type B

Notes

- The screws are 2.6 m/m tapping screws.
- If screws longer than necessary are used, the final gear may be broken or the potentiometer may be damaged or may fall out.

■ Changing the RF module to change the frequency band

- 1 Remove the RF module.
- 2 Change the RF module.

*Use the special FP-TP-FM/FP-TP-AM RF module for the FP-5UAP and 5UAF/5UA. Other RF modules cannot be used.

 - When the transmitter frequency band is changed, the receiver frequency band must be changed also.

■ **Digital Proportional Frequencies (FOR U.S.A.)**

- The frequency of Futaba digital proportional sets can be changed within their own band. There are 2 different bands for you to choose from (50 MHz, 72 MHz and 75 MHz). Please see chart listed below for specific frequency and its intended use. Please note there are specific frequencies allocated for aircraft only and surface only use.
- The frequency can be changed within the same BAND by using a precisely matched pair of Futaba crystals. However, Futaba recommends that you return your system to our factory service department for frequency changing, as tuning may be necessary for proper operation. Changing frequency from one band to another is NOT possible.
- Always change frequency flag when frequency is changed. The frequency flag is to be attached to the top of antenna and the channel designation to the base. (See Drawing)
- It is illegal to change crystals on 75 MHz bands in the U.S.A.

■ **ANTENNA FREQUENCY FLAG**

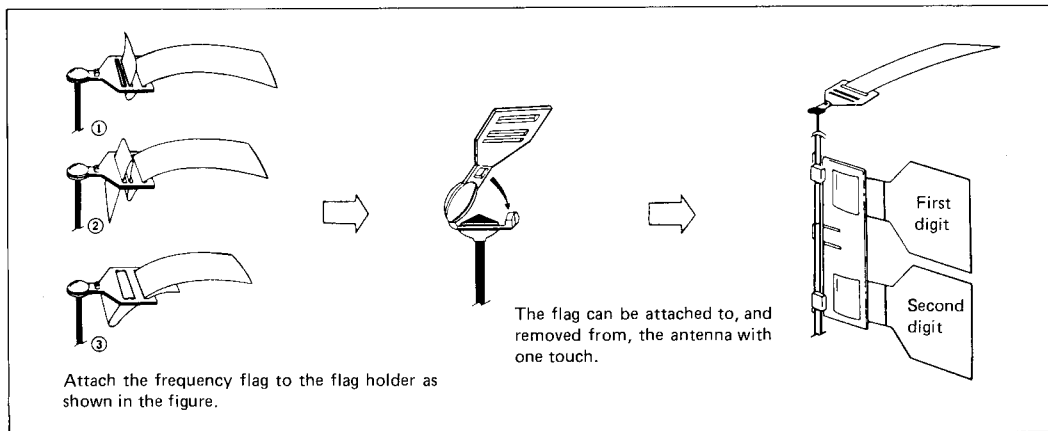

■ **Frequency Channel No. Flag Color (FOR U.S.A.)**

26-27 MHz — Aircraft/car/boat		72 MHz — Aircraft only			
26.995	Brown	72.030	12	*72.470	34
27.045	Red	*72.070	14	72.550	38
27.095	Orange	*72.110	16	72.590	40
27.145	Yellow	*72.150	18	72.630	42
27.195	Green	*72.190	20	72.670	44
27.255	Blue	*72.230	22	72.710	46
		*72.270	24	72.750	48
		*72.310	26	72.790	50
		*72.350	28	72.830	52
		*72.390	30	72.870	54
		*72.430	32	72.910	56
50/53 MHz — Aircraft/car boat — Fcc Amature License required (2 and 3 channels not produced on these frequencies.)		75 MHz — Car/Boat only			
50.800	RC00	75.430	62	75.750	78
50.840	RC02	75.470	64	75.790	80
50.880	RC04	75.510	66	75.830	82
50.920	RC06	75.550	68	75.870	84
50.960	RC08	75.590	70	*75.910	86
	Color	*75.630	72	*75.950	88
53.100	Black—Brown	75.670	74	*75.990	90
53.200	Black—Red	75.710	76		
53.300	Black—Orange				
53.400	Black—Yellow				
53.500	Black—Green				
53.600	Black—Blue				
53.700	Black—Violet				
53.800	Black—Gray				

* Effective JAN 1, 1988

4 FUNCTION AND SETTING METHOD

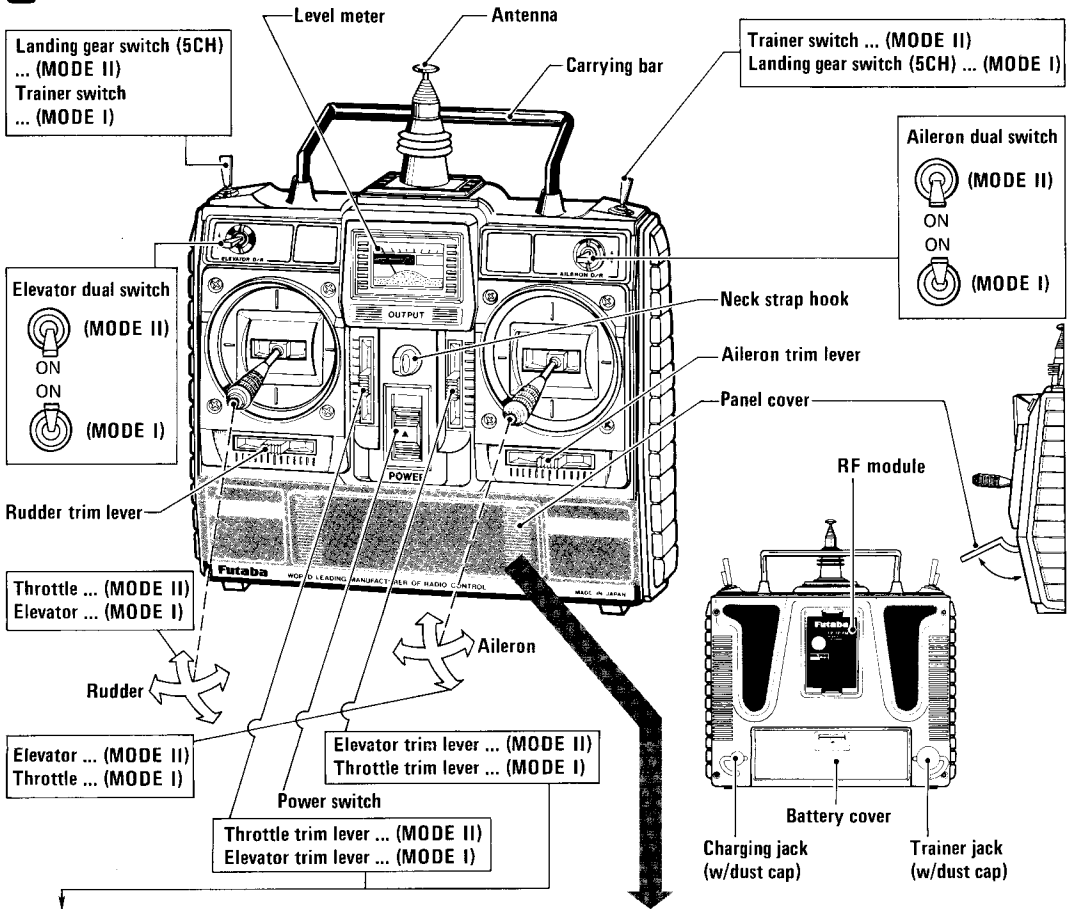

■ ATL (Adjustable throttle limiter)

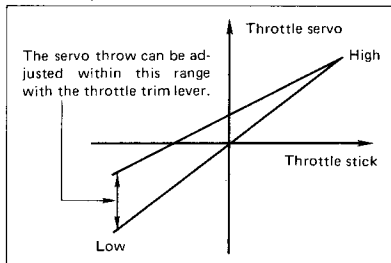

(PANEL)

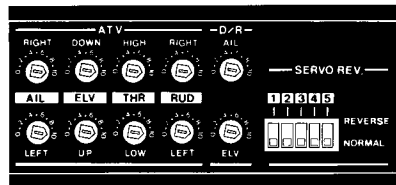

■ Servo reversing switches ... (CH1 ~ CH5)

Up side → Reverse
Down side → Normal (Forward)

■ ATV (Adjustable travel volume) ... (CH1 ~ CH4)

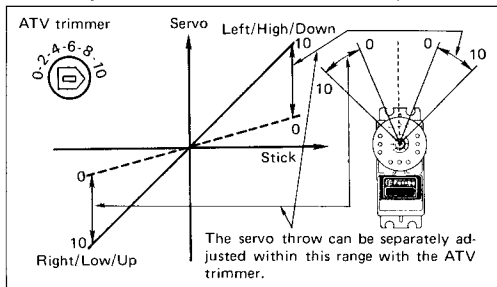

■ D/R (Dual rate) ... (CH1, CH2)

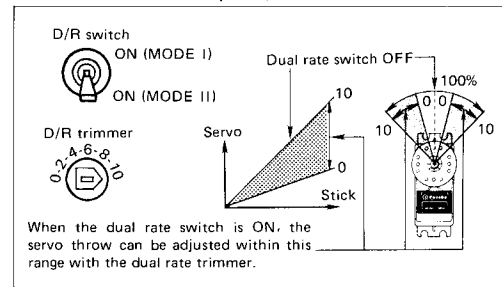

F/S (Fail safe), B-F/S (Battery fail safe), PCM/PPM switching (only FP-5UAP)

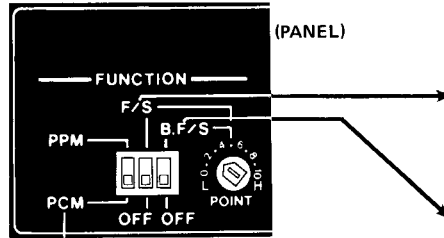

When optional Futaba FM receiver used.

PCM/PPM switching

The modulation can be switched PCM ↔ PPM mode.

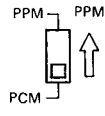

When the mode switch was switched, the transmitter power switch is turned off and transmitter output is obtained the next time the power switch is turned on.

F/S (Fail safe) function

The F/S function allows all servos except throttle to move to a preset neutral position when the receiver cannot receive the signal from the transmitter because of noise or interference. It moves the throttle servo to the preset position.

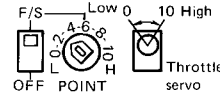

When the F/S switch is ON (F/S side), the throttle servo can be presetted the preset position with the point trimmer.

B-F/S (Battery fail safe) function

The B-F/S function allows all servos except throttle to move to a preset neutral position when the receiver battery voltage drops. It moves the throttle servo to the preset position.

At this time, reset the B-F/S mode and immediately land the aircraft.

1. B-F/S mode position setting

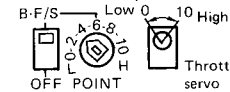

When the B-F/S switch is ON (B-F/S side), the throttle servo can be presetted the preset position with the point trimmer.

2. B-F/S mode resetting method

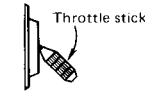

When the throttle stick is set to the maximum slow position, the B-F/S mode is reset.

Stick lever tension adjustment

1 Remove the transmitter back cover.

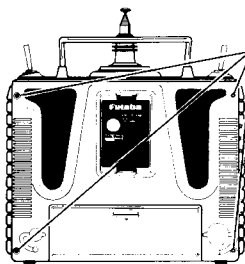

Remove the four screws and remove the back cover.

2 Adjust the spring strength.

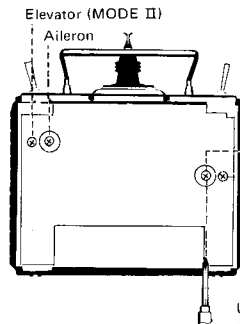

Set to the desired spring strength by turning the screw of each stick.

Use a small Phillips screwdriver.

Non-slip adjustable lever head adjustment

The length of the lever head can be changed.

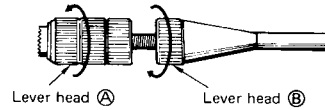

Unlock lever heads ① and ② by turning them in opposite directions as shown by the arrows and adjust the stick to the most comfortable length.

Trainer function (Trainer cable optional)

1 Connection to transmitter

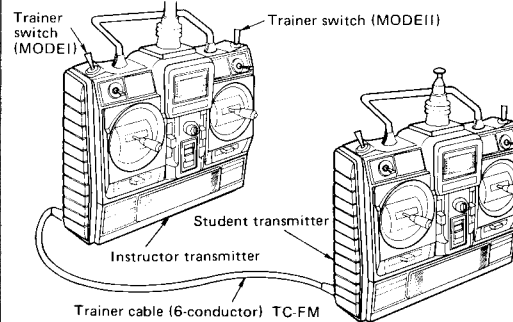

- Operation is impossible if the instructor transmitter modulation mode and student transmitter modulation mode is different.
- Always turn off the student transmitter power switch. Do not operate the trainer switch either.
- Use the functions of the other two transmitters with the same setting.
- Extend the instructor transmitter antenna.

2 Operating at the instructor side

Operation is possible by turning on the instructor transmitter power switch. At this time turn off the trainer switch.

3 Operating at the student side

Operation is possible at the student transmitter while the trainer switch at the instructor side is held in the ON state.

■ SPLINED HORNS

This horn permits shifting of the servo neutral position at the servo horn. Setting and shifting the neutral position.

a) Angle divisions

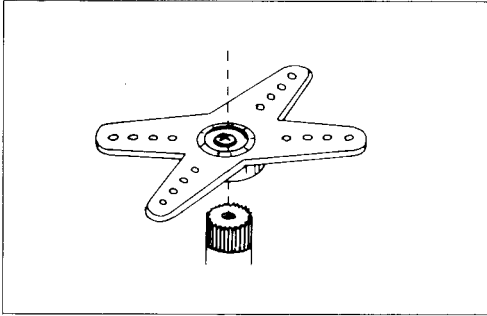

- 1) The splined horn has 25 segments. The amount of change per segment is; $360 \div 25 = 14.4^\circ$.
- 2) The minimum adjustable angle is determined by the number of arms or number of the holes. For four arms, the minimum adjustable angle is:

$$360^\circ \div \frac{(25 \times 4)}{\text{Number of divisions}} = 3.6^\circ$$

b) Effect

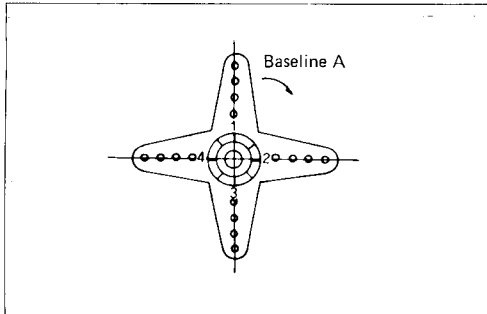

To shift the holes center line to the right (clockwise) relative to baseline A, shift arm 2 to the position of arm 1 and set it to the position closest to baseline A.

[Example] For a four arm horn, the angular shift per segment is 14.4° . The shift to the right is $90^\circ - (14.4 \times 6) = 3.6^\circ$.

To shift by the same angle in the opposite direction, use the opposite arm number.

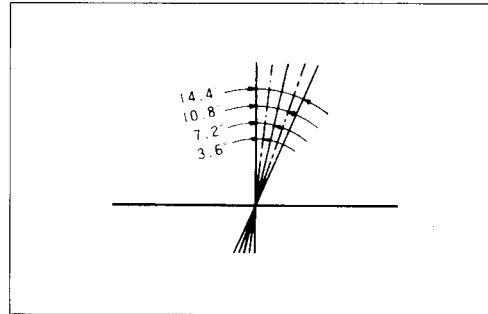

For a six arm horn, turn the arm counterclockwise and set arm 2 to the position of arm 1. The adjustable angle is $60^\circ - (14.4 \times 4) = 2.4^\circ$.

Arm 3 shift 4.8° to the right, arm 6 shifts 2.4° to the left, and arm 4 shifts 7.2° to the right and left.

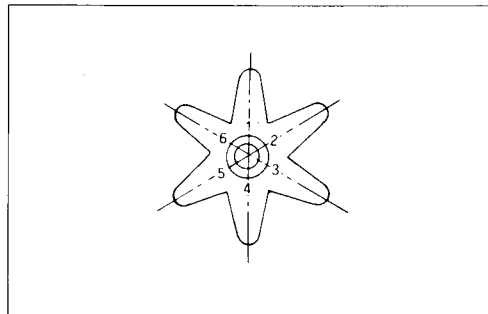

The following splined horns are optional.

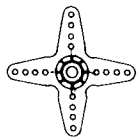

HORN A
(FSH-6X)

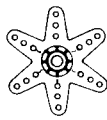

HORN B
(FSH-6S)



HORN C
(FSH-6R)



HORN D
(FSH-6W)



HORN E



HORN F

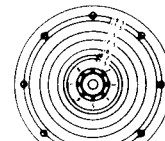

HORN G

5 SERVO EXPLODED VIEW

FP-S148

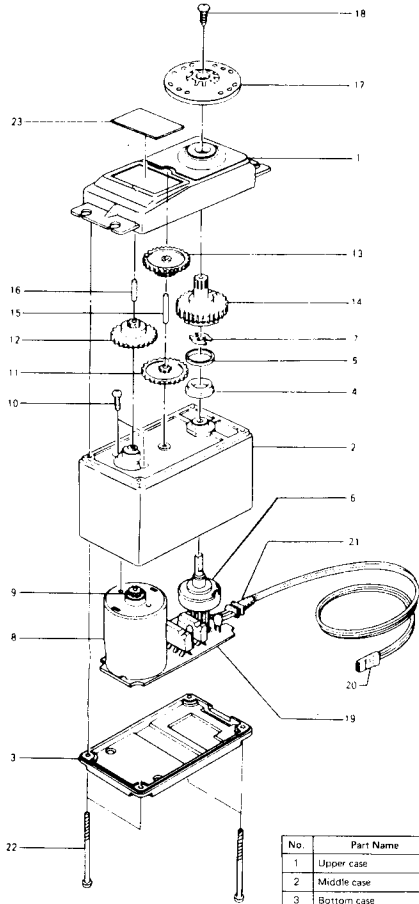

No.	Part Name	Part No.
1	Upper case	S06015
2	Middle case	S06005
3	Bottom case	S06006
4	Metal bearing inner	S04137
5	Metal bearing outer	S04136
6	TR133-15	I39668
7	VR drive plate	S02753
8	Motor	S91239
9	Motor pinion	S02461
10	Motor mounting screw	J50002
11	1st gear	S02490
12	2nd gear	S02491
13	3rd gear	S03266
14	Final gear	S02752
15	Intermediate shaft	S02495
16	2nd shaft	S02494
17	Splined horn D	S01239
18	Horn mounting screw	J55178
19	AMP	AS1157
20	S148...3PB-SWRB300C	AT7453
21	Grommet	S90045
22	Case mounting screw	S50360
23	Nameplate	S60099

FP-S3001

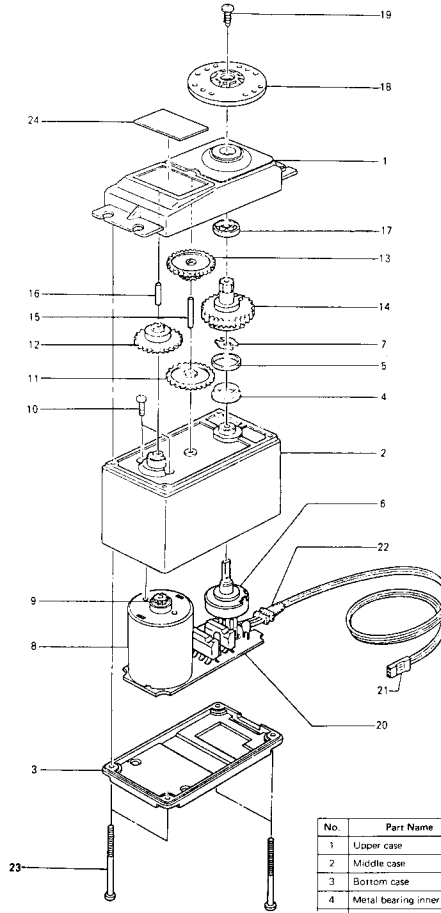

No.	Part Name	Part No.
1	Upper case	S06100
2	Middle case	S06005
3	Bottom case	S06006
4	Metal bearing inner	S04137
5	Metal bearing outer	S04136
6	TR133-15	I39668
7	VR drive plate	S02753
8	Motor	S91239
9	Motor pinion	S02461
10	Motor mounting screw	J50002
11	1st gear	S02490
12	2nd gear	S02491
13	3rd gear	S03266
14	Final gear	S02752
15	Intermediate shaft	S02495
16	2nd shaft	S02494
17	Bearing L-1060	S04130
18	Splined horn D	S01239
19	Horn mounting screw	J55178
20	AMP	AS1341
21	3PB-SWRB300C	AT2453
22	Grommet	S90045
23	Case mounting screw	S50085
24	Nameplate	S60189



FUTABA CORPORATION OF AMERICA
 555 West Victoria Street, Compton, Calif. 90220, U.S.A.
 Phone: 213-537-9610 Telex: 23-0691227 Facsimile: 213-637-8529

FUTABA CORPORATION
 Tokyo Office: Inagaki Bldg., 1-21-3, Kanda Suda-cho, Chiyoda-ku, Tokyo 101, Japan
 Phone: (03) 255-6811 Facsimile: (03) 255-6880

Printed in Japan 891130 GC

