

# Jenny JN-4 Slow Flyer ARF

*Assembly Manual*

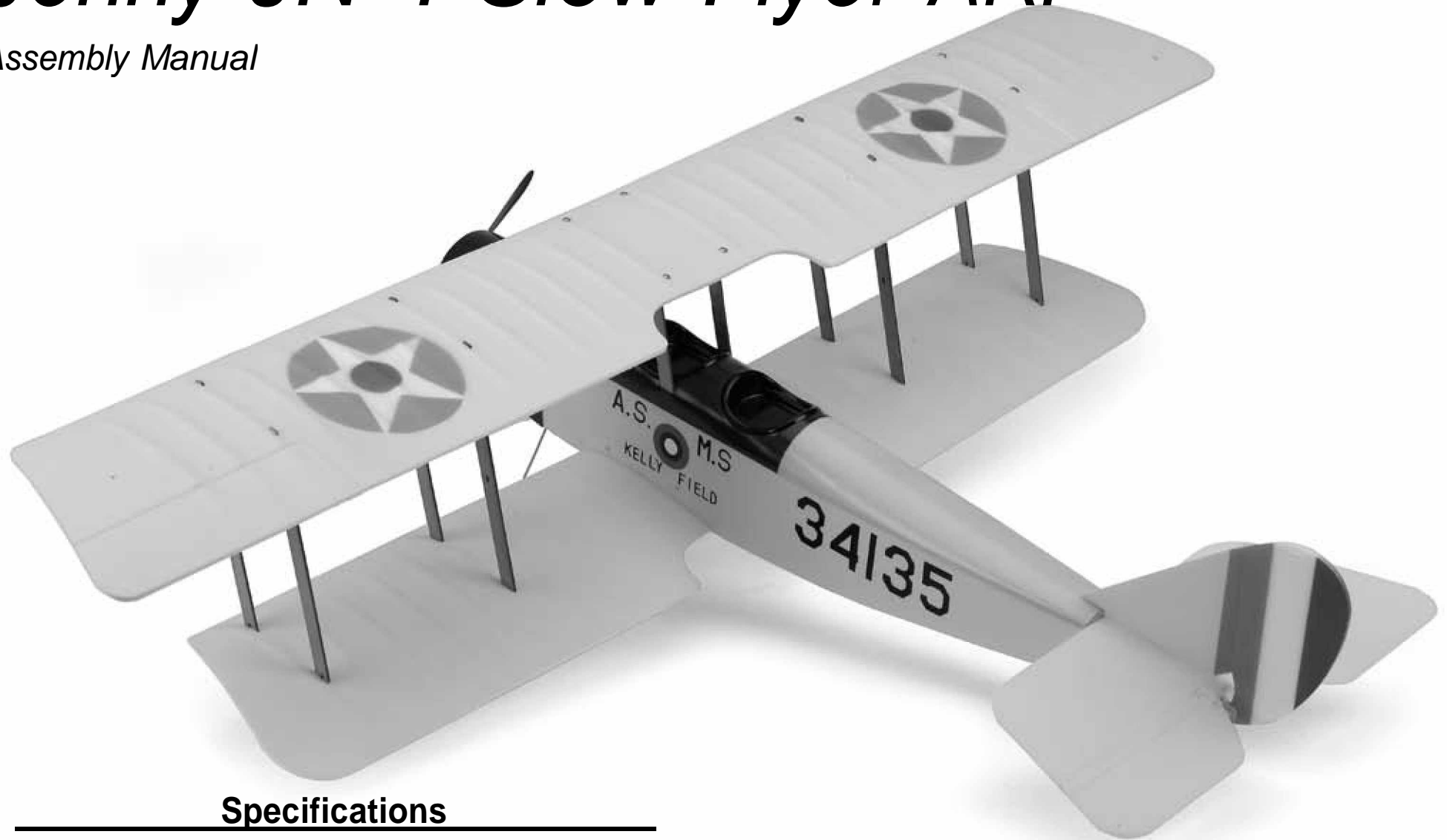

## **Specifications**

---

Wingspan:	32-inch (810mm)
Length:	26-inch (660mm)
Wing Area:	304 sq in (19.6 sq dm)
Weight w/battery:	7.5–8 oz (210–225 g)
Radio:	3-channels with 2 sub-micro servos

**E-flite**<sup>®</sup>  
**ADVANCING ELECTRIC FLIGHT**

Available from: [www.modelflight.com.au](http://www.modelflight.com.au)

## Table of Contents

Specifications .....	1
Introduction.....	2
Using the Manual.....	2
Contents of Kit/Parts Layout.....	3
Required Radio Equipment.....	3
Motor Setup .....	4
Optional Accessories.....	4
Note on Lithium Polymer Batteries .....	4
Required Tools and Adhesives .....	4
Warning.....	4
Warranty Period .....	4
Limited Warranty .....	5
Damage Limits .....	5
Safety Precautions .....	5
Questions, Assistance, and Repairs .....	6
Inspection or Repairs .....	6
Warranty Inspection and Repairs .....	6
Non-Warranty Repairs .....	6
Safety, Precautions, and Warnings .....	7
Motor Installation .....	7
Rudder and Elevator Installation .....	10
Radio Installation.....	12
Wing Installation.....	15
Landing Gear Installation.....	18
Wing Rigging Installation.....	19
Control Throws.....	21
Center of Gravity .....	22
Range Test Your Radio .....	22
Preflight .....	23
Flying the Jenny JN-4 Slow Flyer.....	23
2007 Official AMA National Model Aircraft Safety Code .....	24

## Introduction

The Curtiss JN-4 “Jenny” first entered service during WWI as a primary trainer for the fledgling U.S. Army Air Corps. After the war, surplus Jenny’s found fame with enterprising barnstormers who crisscrossed the countryside performing air shows and giving awe-struck passengers their first taste of flight. E-flite® captures the magic of this golden era in the history of flight with this superb Jenny replica. In addition to its outstanding scale detail, E-flite has given this Jenny excellent slow flight characteristics that make it perfect for indoor flight.

## Using the Manual

This manual is divided into sections to help make assembly easier to understand, and to provide breaks between each major section. In addition, check boxes have been placed next to each step to keep track of each step completed. Steps with a single circle ( ) are performed once, while steps with two circles ( ) indicate that the step will require repeating, such as for a right or left wing panel, two servos, etc.

Remember to take your time and follow the directions.

## Contents of Kit/Parts Layout

### Large Replacement Parts

EFL1901	Wing (Top and Bottom)
EFL1902	Fuselage
EFL1903	Cowling
EFL1904	Tail Set
EFL1905	Main Landing Gear w/Wheels
EFLM1960	Carbon Fiber Tube, 6-inch (152mm), 8mm OD, 6mm ID: Park 250

### Small Replacement Parts

EFLA213	E-flite/JR/Horizon Decals
---------	---------------------------

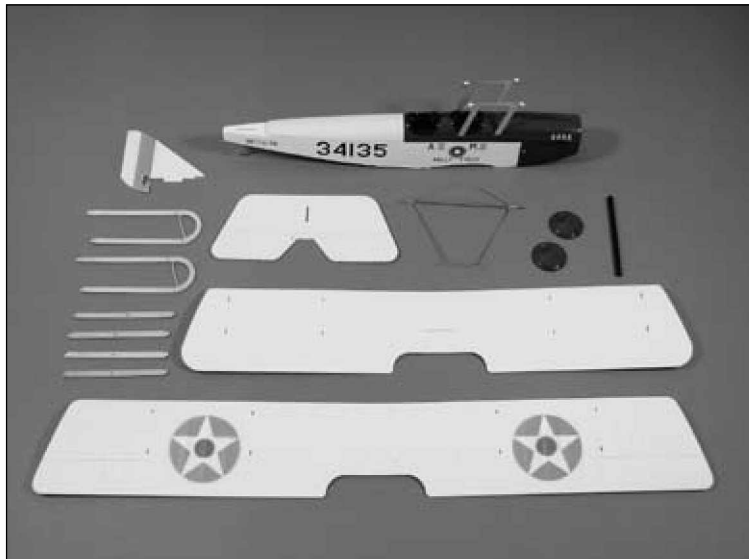

## Required Radio Equipment

You will need a minimum 4-channel transmitter, crystals, micro receiver, and two sub-micro servos. You can choose to purchase a complete radio system that includes all of these items or, if you are using an existing transmitter, just purchase the other required equipment separately. We recommend the crystal-free, interference-free Spektrum™ DX6 2.4GHz DSM® 6-channel system.

### Complete Radio System

SPM2460     DX6 DSM 6CH Park Flyer

### Alternate Radio System

SPM2710     DX7 DSM2 7CH System with AR6100 Microlite 6-Channel Receiver

### Or Purchase Separately

JSP30610     6-Channel UltraLite Rx w/o Crystal, Positive Shift  
JR/AIR (72MHz)  
JSP30615     6-Channel UltraLite Rx w/o Crystal, Negative Shift  
Fut/HRC (72MHz)  
JRPXFR\*\*     FM Receiver Crystal (JR only, not AR6000)

### Or

SPM6000     AR6000 DSM 6-Channel Park Flyer Receiver  
SPM6100     AR6100 DSM2 Microlite 6-Channel Receiver (must  
be used with the DX7)

### And

EFLRS60     6.0g Super Sub-Micro S60 Servo (2)

## Motor Setup

---

EFLM1130	Park 250 Outrunner, 2200Kv
EFLA1010	10A Brushless ESC
THP4802SJPL	480mAh 2-Cell 7.4V Li-Po, JST
GWSEP6050B	Electric Propeller, 6x5 Slow-Flyer
EFLC3005	Celectra 1- to 3-cell Li-Po Charger

## Optional Accessories

---

EFLA110	Power Meter
HAN172	Hangar 9 Digital Servo and Rx Current Meter

## Note on Lithium Polymer Batteries

---



Lithium Polymer batteries are significantly more volatile than alkaline or Ni-Cd/Ni-MH batteries used in RC applications. All manufacturer's instructions and warnings must be followed closely. Mishandling of Li-Po batteries can result in fire. Always follow the manufacturer's instructions when disposing of Lithium Polymer batteries.

## Required Tools and Adhesives

---

### Tools & Equipment

EFLA250 Park Flyer Tool Assortment, 5-piece

### Or Purchase Separately

EFLA257 Screwdriver, #0 Phillips (or included with EFLA250)

Hobby knife

Felt-tipped pen

Square

Sandpaper

### Adhesives

EFLA208 Foam CA 1oz/Activator 2oz Pack

RTV silicone

## Warning

---

An RC aircraft is not a toy! If misused, it can cause serious bodily harm and damage to property. Fly only in open areas, preferably at AMA (Academy of Model Aeronautics) approved flying sites, following all instructions included with your radio. Keep loose items that can get entangled in the propeller away from the prop, including loose clothing, or other objects such as pencils and screwdrivers. Especially keep your hands away from the propeller.

## Warranty Period

---

Horizon Hobby, Inc., (Horizon) warrants that the Products purchased (the "Product") will be free from defects in materials and workmanship at the date of purchase by the Purchaser.

## Limited Warranty

---

(a) This warranty is limited to the original Purchaser ("Purchaser") and is not transferable. REPAIR OR REPLACEMENT AS PROVIDED UNDER THIS WARRANTY IS THE EXCLUSIVE REMEDY OF THE PURCHASER. This warranty covers only those Products purchased from an authorized Horizon dealer. Third party transactions are not covered by this warranty. Proof of purchase is required for warranty claims. Further, Horizon reserves the right to change or modify this warranty without notice and disclaims all other warranties, express or implied.

(b) Limitations- HORIZON MAKES NO WARRANTY OR REPRESENTATION, EXPRESS OR IMPLIED, ABOUT NON-INFRINGEMENT, MERCHANTABILITY OR FITNESS FOR A PARTICULAR PURPOSE OF THE PRODUCT. THE PURCHASER ACKNOWLEDGES THAT THEY ALONE HAVE DETERMINED THAT THE PRODUCT WILL SUITABLY MEET THE REQUIREMENTS OF THE PURCHASER'S INTENDED USE.

(c) Purchaser Remedy- Horizon's sole obligation hereunder shall be that Horizon will, at its option, (i) repair or (ii) replace, any Product determined by Horizon to be defective. In the event of a defect, these are the Purchaser's exclusive remedies. Horizon reserves the right to inspect any and all equipment involved in a warranty claim. Repair or replacement decisions are at the sole discretion of Horizon. This warranty does not cover cosmetic damage or damage due to acts of God, accident, misuse, abuse, negligence, commercial use, or modification of or to any part of the Product. This warranty does not cover damage due to improper installation, operation, maintenance, or attempted repair by anyone other than Horizon. Return of any goods by Purchaser must be approved in writing by Horizon before shipment.

## Damage Limits

---

HORIZON SHALL NOT BE LIABLE FOR SPECIAL, INDIRECT OR CONSEQUENTIAL DAMAGES, LOSS OF PROFITS OR PRODUCTION OR COMMERCIAL LOSS IN ANY WAY CONNECTED WITH THE PRODUCT, WHETHER SUCH CLAIM IS BASED IN CONTRACT, WARRANTY, NEGLIGENCE, OR STRICT LIABILITY. Further, in no event shall the liability of Horizon exceed the individual price of the Product on which liability is asserted. As Horizon has no control over use, setup, final assembly, modification or misuse, no liability shall be assumed nor accepted for any resulting damage or injury. By the act of use, setup or assembly, the user accepts all resulting liability.

If you as the Purchaser or user are not prepared to accept the liability associated with the use of this Product, you are advised to return this Product immediately in new and unused condition to the place of purchase.

Law: These Terms are governed by Illinois law (without regard to conflict of law principals).

## Safety Precautions

---

This is a sophisticated hobby Product and not a toy. It must be operated with caution and common sense and requires some basic mechanical ability. Failure to operate this Product in a safe and responsible manner could result in injury or damage to the Product or other property. This Product is not intended for use by children without direct adult supervision. The Product manual contains instructions for safety, operation and maintenance. It is essential to read and follow all the instructions and warnings in the manual, prior to assembly, setup or use, in order to operate correctly and avoid damage or injury.

## Questions, Assistance, and Repairs

Your local hobby store and/or place of purchase cannot provide warranty support or repair. Once assembly, setup or use of the Product has been started, you must contact Horizon directly. This will enable Horizon to better answer your questions and service you in the event that you may need any assistance. For questions or assistance, please direct your email to [productsupport@horizonhobby.com](mailto:productsupport@horizonhobby.com), or call 877.504.0233 toll free to speak to a service technician.

## Inspection or Repairs

If this Product needs to be inspected or repaired, please call for a Return Merchandise Authorization (RMA). Pack the Product securely using a shipping carton. Please note that original boxes may be included, but are not designed to withstand the rigors of shipping without additional protection. Ship via a carrier that provides tracking and insurance for lost or damaged parcels, as *Horizon is not responsible for merchandise until it arrives and is accepted at our facility*. A Service Repair Request is available at [www.horizonhobby.com](http://www.horizonhobby.com) on the "Support" tab. If you do not have internet access, please include a letter with your complete name, street address, email address and phone number where you can be reached during business days, your RMA number, a list of the included items, method of payment for any non-warranty expenses and a brief summary of the problem. Your original sales receipt must also be included for warranty consideration. Be sure your name, address, and RMA number are clearly written on the outside of the shipping carton.

## Warranty Inspection and Repairs

*To receive warranty service, you must include your original sales receipt* verifying the proof-of-purchase date. Provided warranty conditions have been met, your Product will be repaired or replaced free of charge. Repair or replacement decisions are at the sole discretion of Horizon Hobby.

## Non-Warranty Repairs

*Should your repair not be covered by warranty the repair will be completed and payment will be required without notification or estimate of the expense unless the expense exceeds 0% of the retail purchase cost.* By submitting the item for repair you are agreeing to payment of the repair without notification. Repair estimates are available upon request. You must include this request with your repair. Non-warranty repair estimates will be billed a minimum of ½ hour of labor. In addition you will be billed for return freight. Please advise us of your preferred method of payment. Horizon accepts money orders and cashiers checks, as well as Visa, MasterCard, American Express, and Discover cards. If you choose to pay by credit card, please include your credit card number and expiration date. Any repair left unpaid or unclaimed after 90 days will be considered abandoned and will be disposed of accordingly. *Please note: non-warranty repair is only available on electronics and model engines.*

Electronics and engines requiring inspection or repair should be shipped to the following address:

Horizon Service Center  
4105 Fieldstone Road  
Champaign, Illinois 61822

All other Products requiring warranty inspection or repair should be shipped to the following address:

Horizon Product Support  
4105 Fieldstone Road  
Champaign, Illinois 61822

*Please call 877- 04-0 with any questions or concerns regarding this product or warranty.*

## **Safety, Precautions, and Warnings**

As the user of this product, you are solely responsible for operating it in a manner that does not endanger yourself and others or result in damage to the product or the property of others.

Carefully follow the directions and warnings for this and any optional support equipment (chargers, rechargeable battery packs, etc.) that you use.

This model is controlled by a radio signal that is subject to interference from many sources outside your control. This interference can cause momentary loss of control so it is necessary to always keep a safe distance in all directions around your model, as this margin will help to avoid collisions or injury.

- Always operate your model in an open area away from cars, traffic, or people.
- Avoid operating your model in the street where injury or damage can occur.
- Never operate the model out into the street or populated areas for any reason.
- Never operate your model with low transmitter batteries.
- Carefully follow the directions and warnings for this and any optional support equipment (chargers, rechargeable battery packs, etc.) that you use.
- Keep all chemicals, small parts and anything electrical out of the reach of children.
- Moisture causes damage to electronics. Avoid water exposure to all equipment not specifically designed and protected for this purpose.

# Motor Installation

## Required Parts

- Fuselage
- Park 250 Brushless motor
- 1 $\frac{1}{2}$ -inch (38mm) motor tube
- Receiver
- Electronic speed control (ESC)

## Required Tools and Adhesives

- Phillips screwdriver
- Double-sided tape
- Sandpaper
- RTV silicone
- Foam-safe CA

1. Locate the 1 $\frac{1}{2}$ -inch (38mm) motor tube. Follow the instructions to glue (using RTV silicone) the motor to the motor tube. Be careful not to get glue inside the motor



2. Lightly sand the motor tube once the adhesive used to glue the motor to the motor tube has fully cured.



3. Remove the two screws holding the cowl to the fuselage and slide the cowl away from the fuselage.

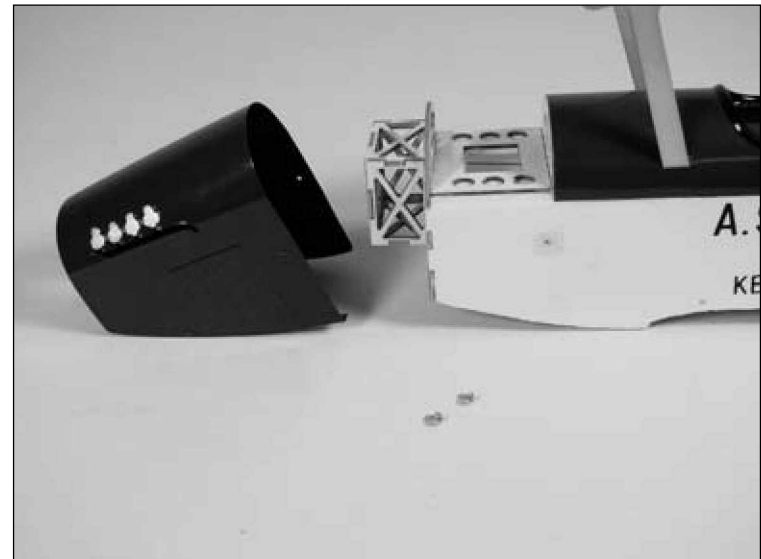

4. Slide the motor assembly into the fuselage.

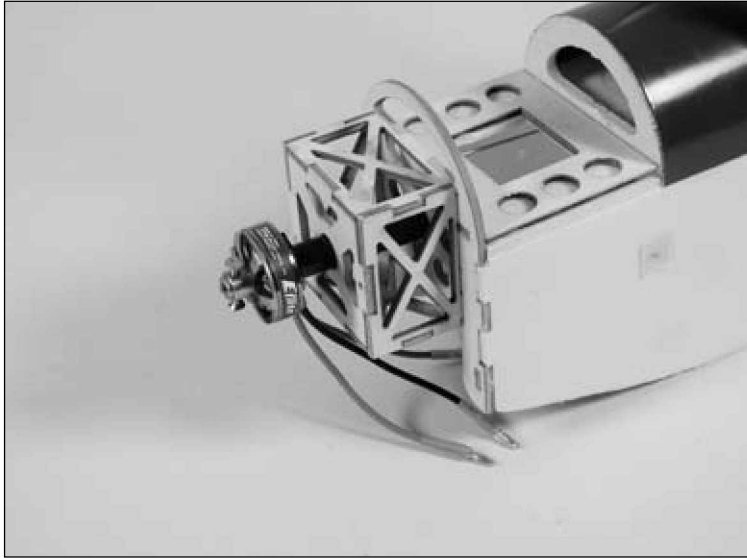

5. Slide the cowl back in position and attach it to the fuselage. Attach the propeller to the motor following the instructions provided with the motor.

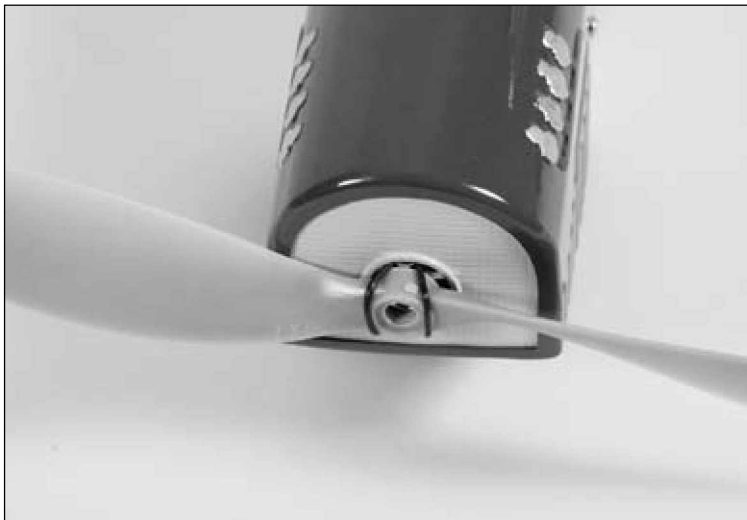

6. Position the motor so it does not rub against the cowl. Apply a few drops of foam-safe CA to the intersection of the fuselage and motor tube.



7. Once the CA has cured, remove the propeller and cowl. Apply foam-safe CA to the tube at the front of the motor box.

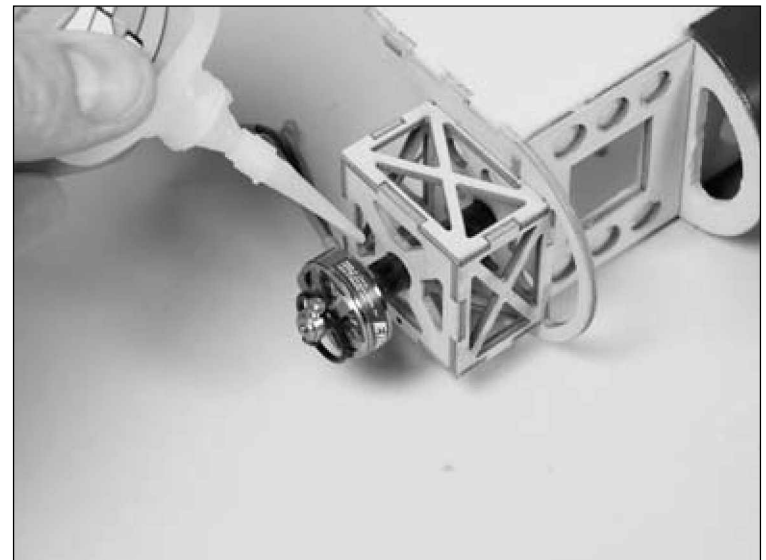

8. Plug the leads from the motor to the speed control. Attach the speed control using double-sided tape as shown.

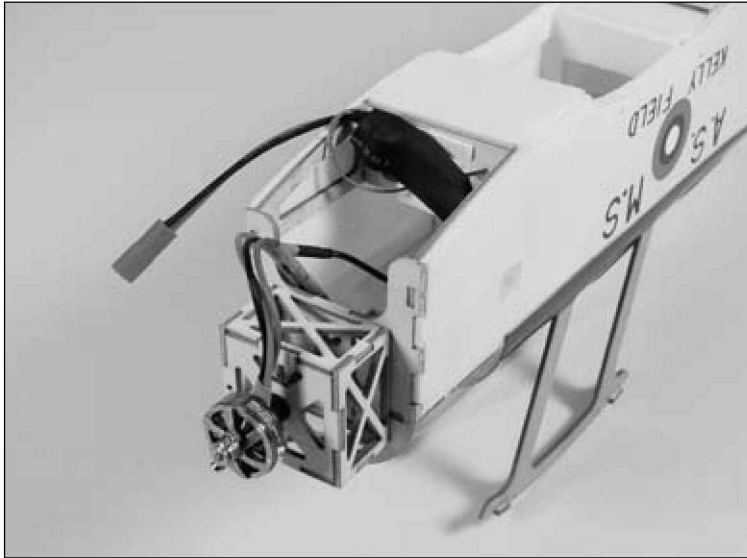

9. Use double-sided tape to secure the receiver inside the fuselage. Position the antenna wires according to your radio manual. Never shorten the receiver antenna wire, as this will greatly reduce the range of your radio system.

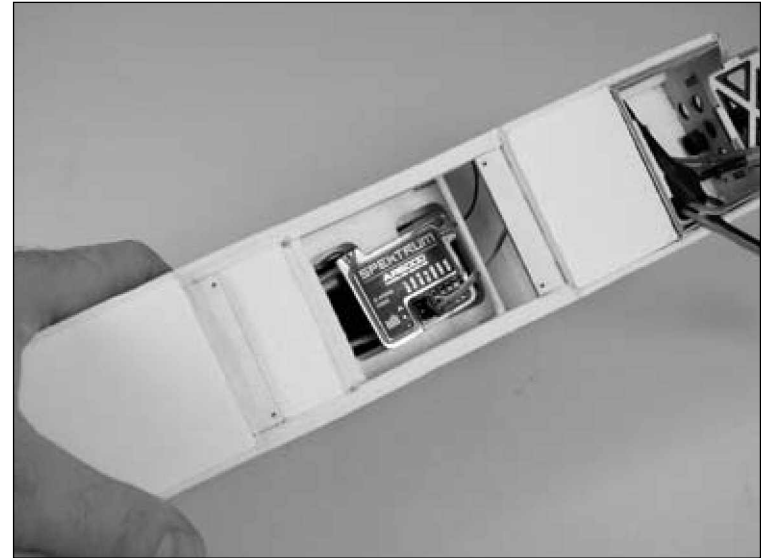

10. Turn on the transmitter and bring the throttle trim and stick to the low throttle position. Plug the battery into the speed control and check the operation of the motor. It should rotate counterclockwise when viewed from the front of the aircraft. Use the instructions provided with your ESC to make corrections to the direction of rotation of the motor if necessary.

## Rudder and Elevator Installation

### Required Parts

- Rudder/Fin
- Elevator/Stabilizer
- Micro control horn (2)
- Micro control horn backplate (2)

### Required Tools and Adhesives

- Square
- Foam-safe CA
- Sandpaper

1. Position the rudder/fin tab into the slot in the stabilizer/elevator. The yellow side of the stabilizer/elevator faces the rudder/fin. Use a square and foam-safe CA to glue the two items together, making sure the rudder/fin is square to the stabilizer/elevator.

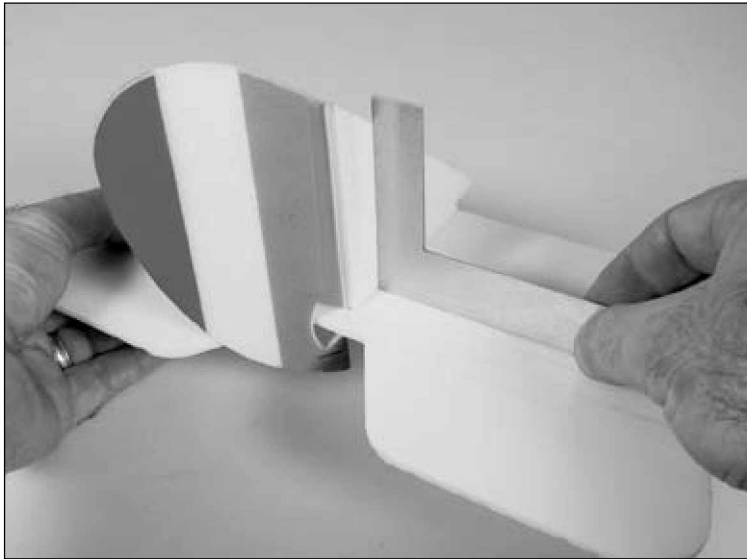

2. Slide a micro control horn into the slot in the elevator from the bottom.

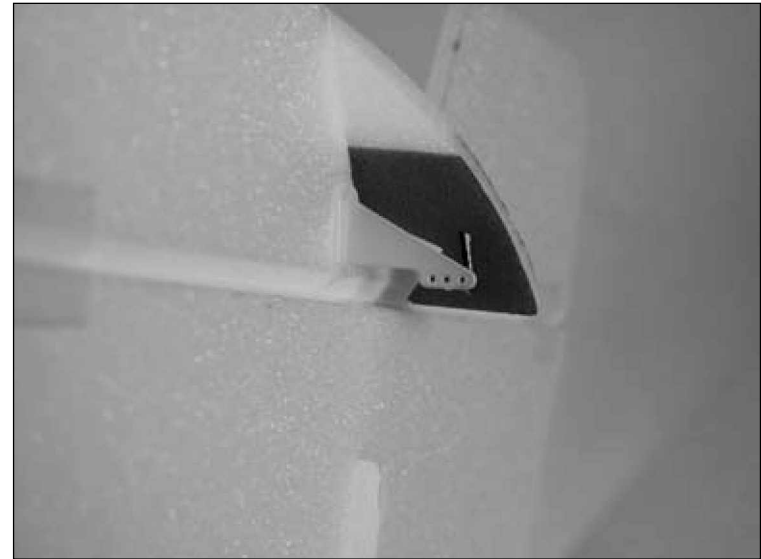

3. Slide the micro control horn backplate onto the control horn from the opposite side of the elevator as the horn. Apply a few drops of foam-safe CA onto the backplate to secure it to the horn.

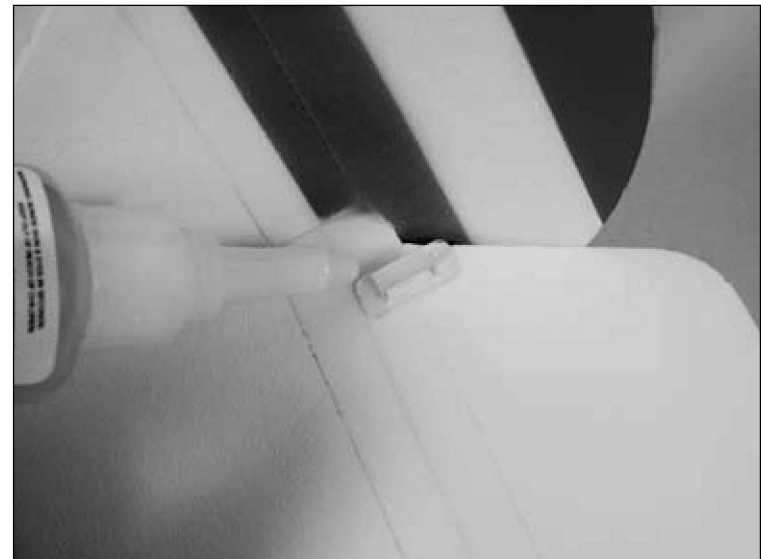

4. Repeat Steps 2 and 3 to install the rudder control horn.

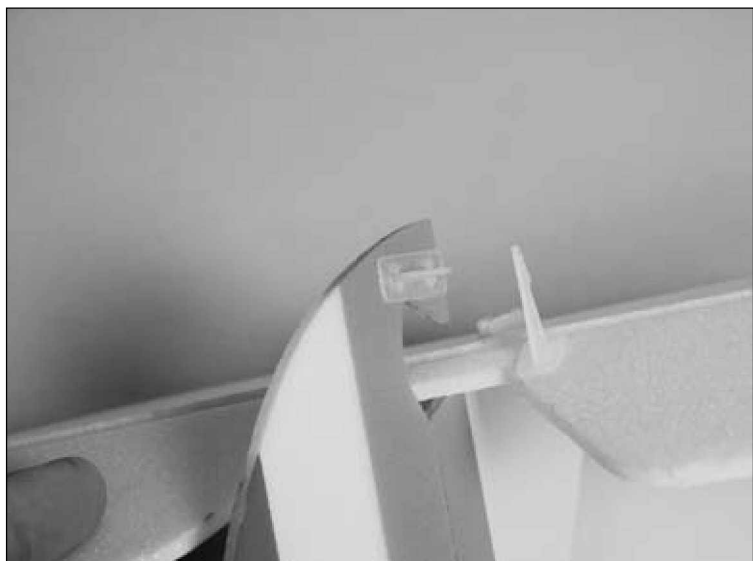

*Note:* The rudder horn is opposite the elevator horn.

5. Position the assemble onto the fuselage. Check the alignment as shown in the drawing. The rudder must be parallel to the cabane struts. If not, lightly sand the fuselage where the elevator rests and check the alignment again. Once the alignment is correct, use foam-safe CA to glue the assembly to the fuselage.

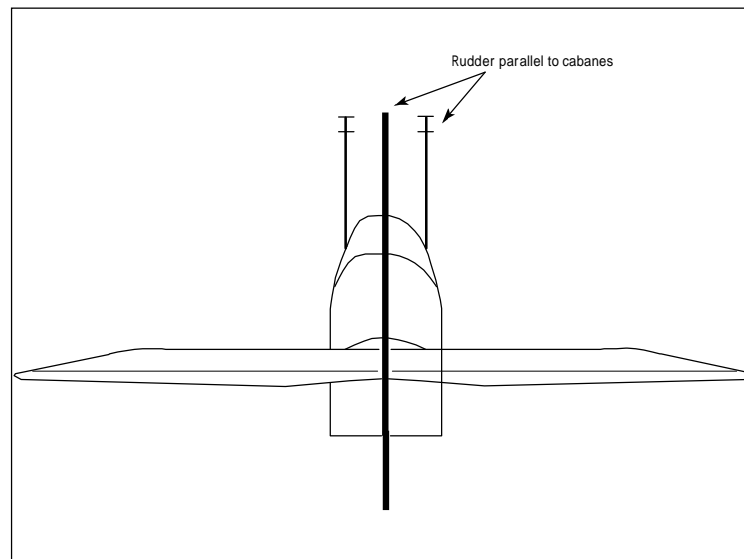

# Radio Installation

## Required Parts

- Assembled fuselage
- Sub-micro servo (2)
- Micro pushrod connector (2)
- 2mm x 4mm machine screw (2)
- Micro pushrod connector backplate (2)

## Required Tools and Adhesives

- Hobby knife
- Phillips screwdriver

1. Use a hobby knife to enlarge the outer hole in the servo arm. Slide the micro pushrod connector into the hole.

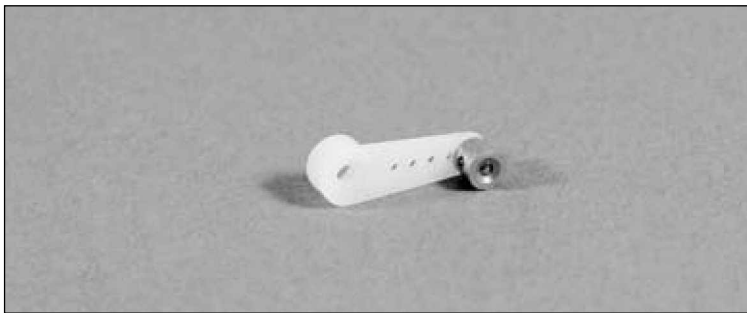

2. Secure the micro pushrod connector using a micro pushrod connector backplate.



3. Mount the elevator servo in the fuselage using the screws provided with the servo.

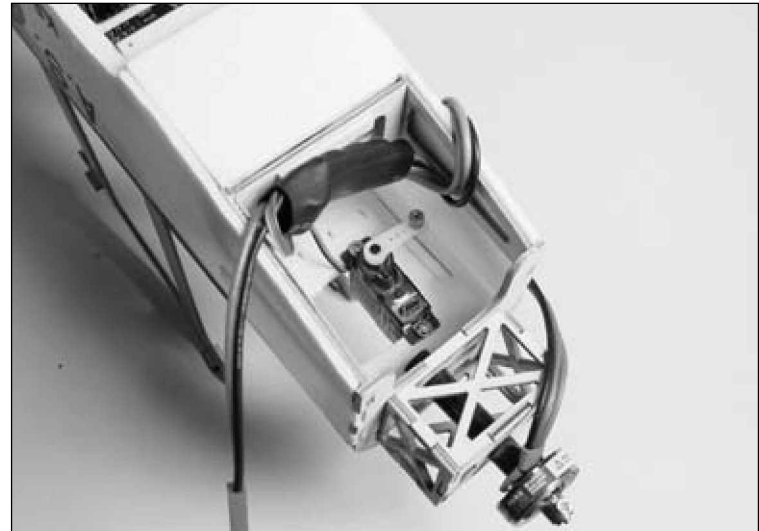

4. Slide the elevator pushrod wire through the center hole in the control horn. Place a small bend in the pushrod wire to apply light tension to keep the pushrod wire from popping out of the horn.

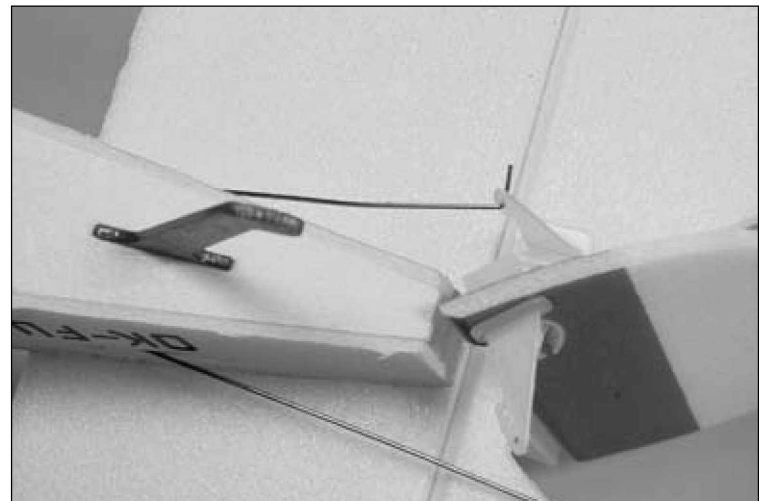

5. Check to make sure the elevator and stabilizer are parallel.



6. Slide the pushrod wire through the connector. With the elevator centered, thread a 2mm x 4mm machine screw in the connector and tighten it to secure the pushrod wire.

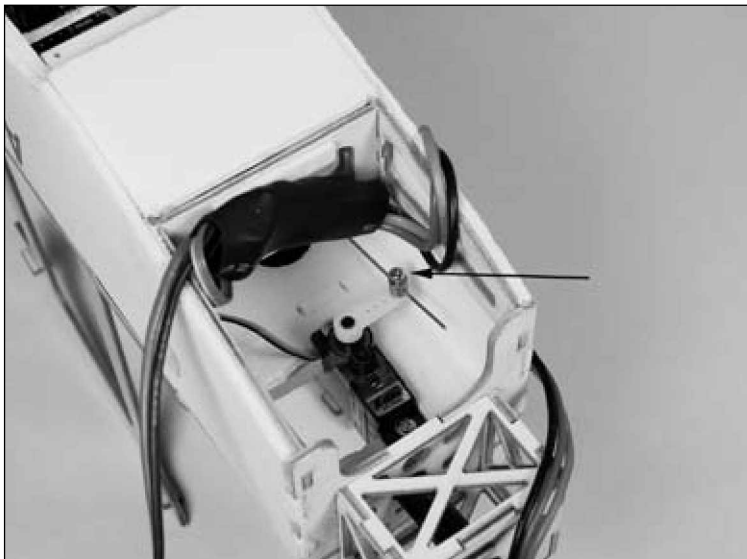

7. Repeat Steps 1 through 6 to install the rudder servo and linkage.

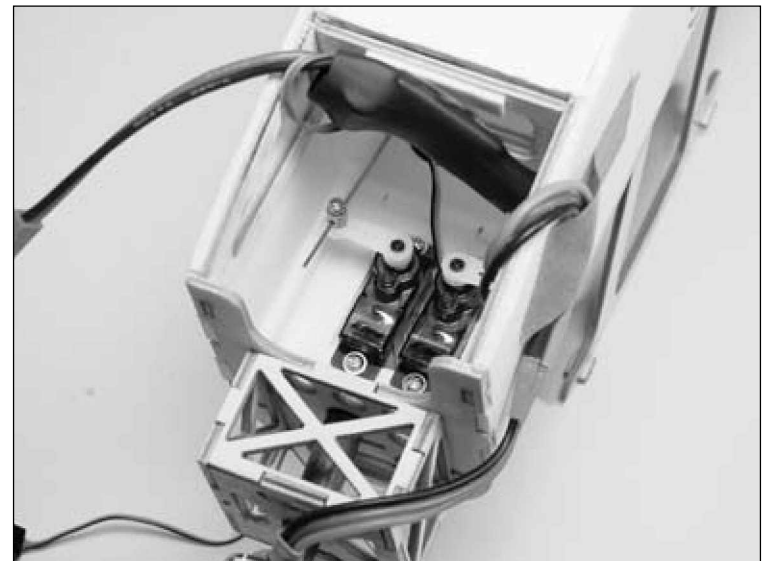
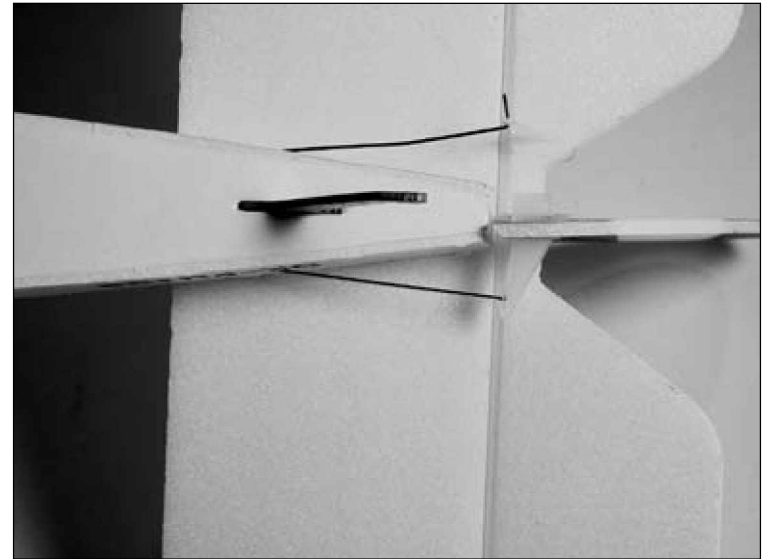

8. Reinstall the cowl and propeller. If the motor rubs on the cowl, enlarge the holes for the screws that secure the cowl so it can be repositioned enough so the motor does not rub the cowl.

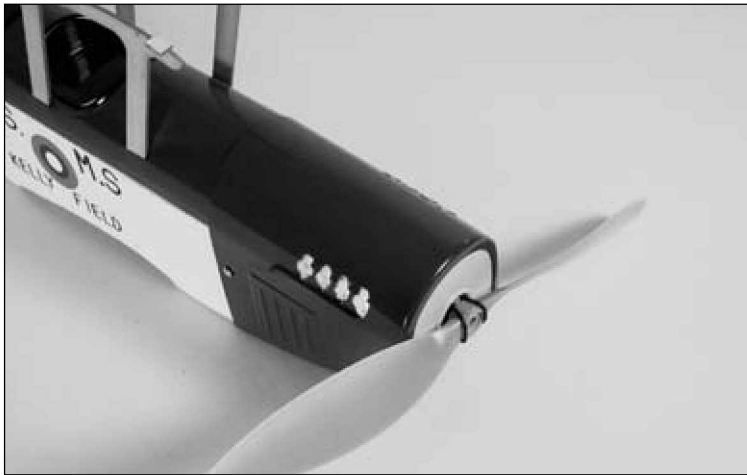

9. Use hook and loop tape to secure the battery inside the cowl. The battery can be moved forward or backward to adjust the Center of Gravity.



*Note:* We have found the model to balance out when using a Thunder Power 480 2-cell battery with the equipment listed in this manual. Using a 730 2-cell battery will move the CG forward just a small amount and will not affect the flight characteristics.

# Wing Installation

## Required Parts

- Wing (top and bottom)
- Inner strut (front) (2)
- 2mm x 4mm sheet metal screw (8)
- Outer strut (2)
- Inner strut (rear) (2)

## Required Tools and Adhesives

- Phillips screwdriver
- Hobby knife
- Foam-safe CA
- Felt-tipped pen

1. Position the bottom wing on the fuselage. Line the holes in the wing up with the holes in the cross supports in the fuselage. Use four 2mm x 4mm sheet metal screws to attach the bottom wing to the fuselage. Do not over-tighten the screws and damage the wing.



2. Slide the outer struts through the bottom wing. Note the direction of the strut. The rear has an angle, while the front is straight.

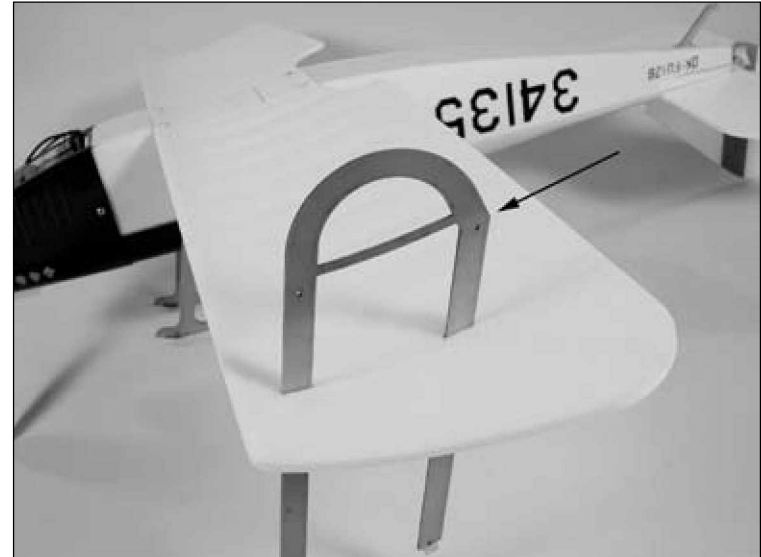

3. Use a hobby knife to make two small holes in the mounting points of the cabane struts. Make the hole in the rear mounting pads at this time.



4. Use a felt-tipped pen to mark the holes made in the previous step. This will help in sighting the holes through the wing.



5. Attach the rear of the top wing using two 2mm x 4mm sheet metal screws. Mark the locations for the front screws through the wing on the mounting pads. The cabane struts may require some adjustments to line up with the holes in the wing.



6. Repeat the procedure from Steps 3 and 4 to make the holes on the mounting pads at the front of the cabane struts. Attach the wing using a total of four 2mm x 4mm sheet metal screws.

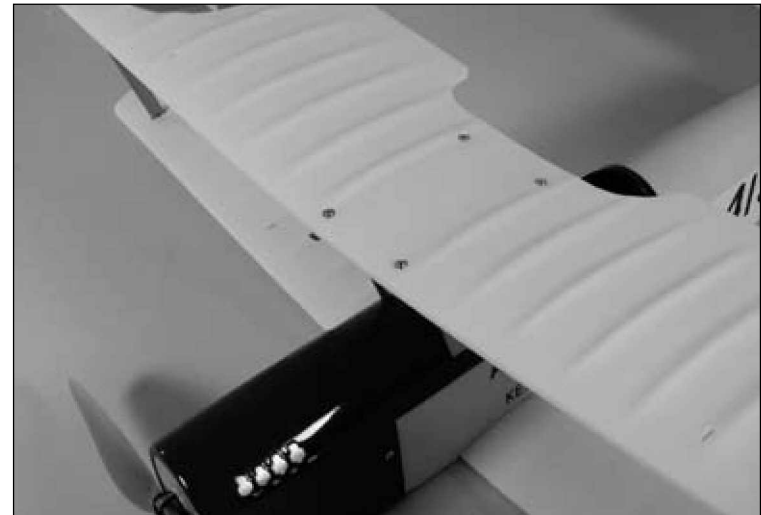

*Note:* The alignment of the wings is very important for smooth, predictable flight. Take your time during the next few steps to ensure you do not build a warp into the wing platform at any time.

7. Apply foam-safe CA to the strut where it will come in contact with the bottom wing. Push the strut tight against the wing.

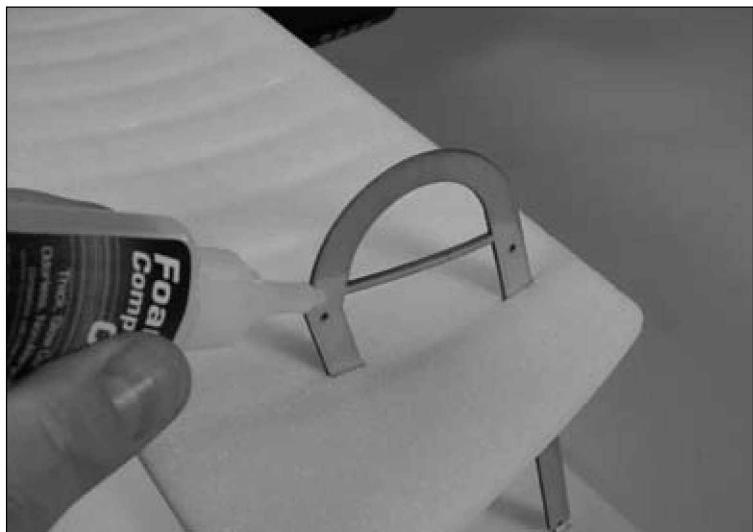

8. Apply foam-safe CA to the ends of the struts where they come in contact with the top wing. Slide the struts into position and hold the strut while the CA cures.

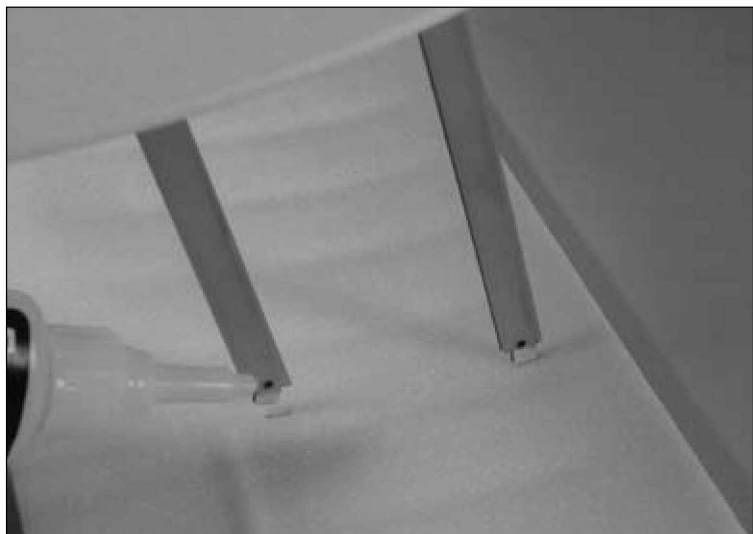

9. Locate the inner struts. Select a front and rear strut. The rear strut has a greater angle than the front as shown in the photo below.

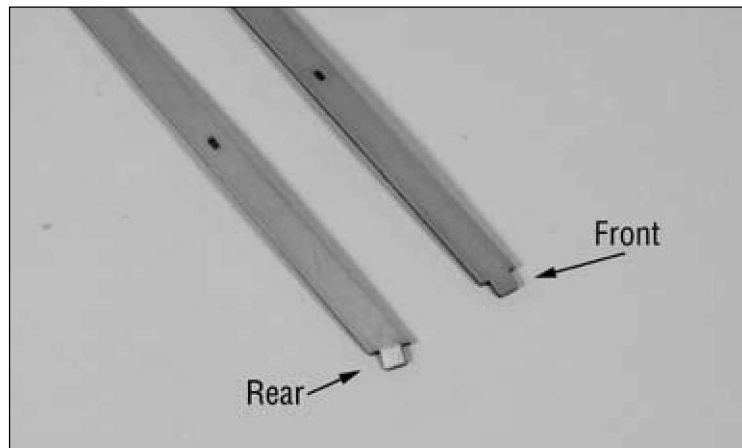

10. Position the inner struts between the top and bottom wing. Use foam-safe CA to glue the struts to the wings.

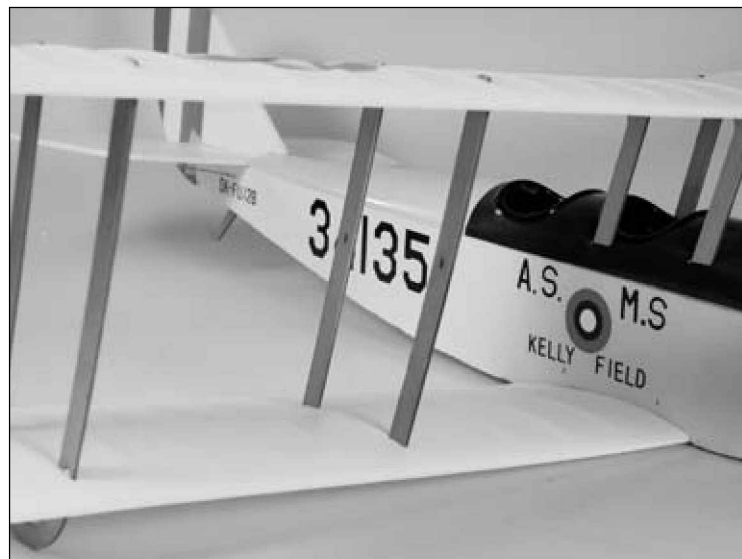

11. Repeat Steps 9 and 10 to install the remaining inner struts.

# Landing Gear Installation

## Required Parts

- Airframe
- Landing gear
- Wheel (2)
- Wheel retainer (2)

## Required Tools and Adhesives

- Foam-safe CA

1. Locate the landing gear. Position the gear with the main axle toward the front of the plane.



2. Press the front of the gear into the opening in the fuselage.



3. Press the rear of the gear into the slot in the wing and into the fuselage.

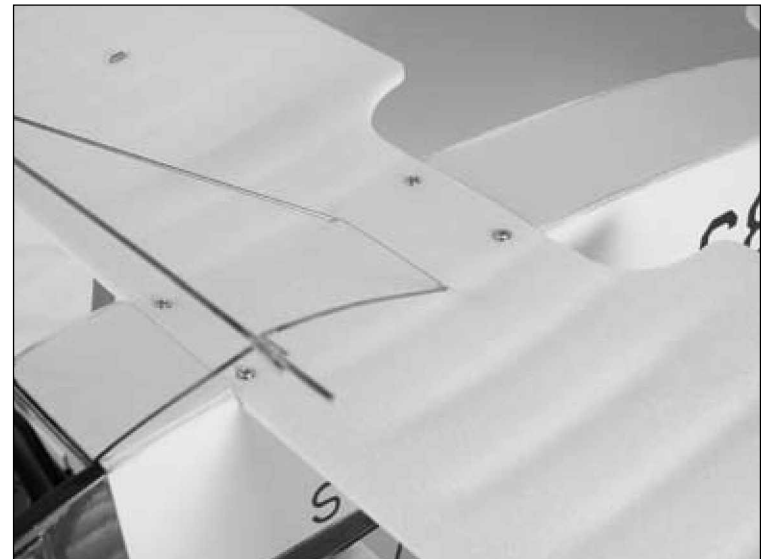

4. Slide a wheel onto the axle. Use a wheel retainer to secure the wheel.



*Hint:* Use medium foam-safe CA on the retainer if it is not snug on the axle. Use care not to glue the wheel to the axle.

## Wing Rigging Installation

### Required Parts

- Airframe
- Rigging thread

### Required Tools and Adhesives

- Foam-safe CA

*Note:* Installing the rigging will add to the appearance and strength of your airplane, but you will not be able to remove the wings without cutting the rigging. The rigging is required if you plan on any type of aggressive flying with your Jenny.

1. Pass the rigging thread through the hole in the outer strut as shown.

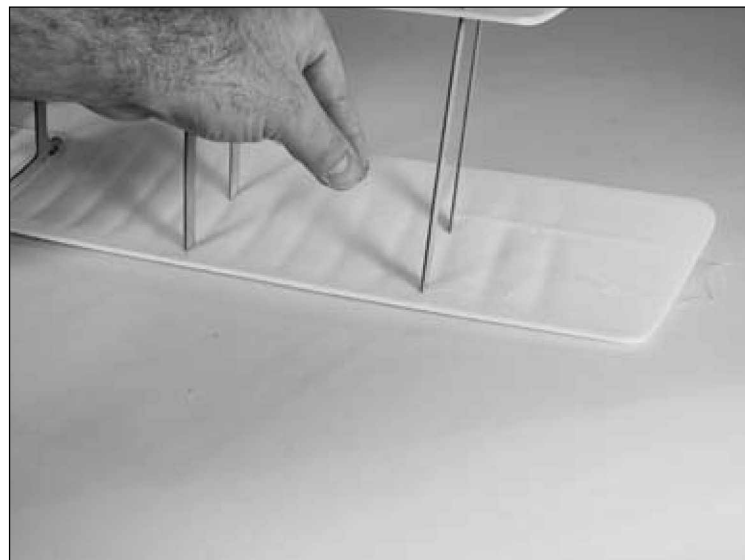

2. Guide the thread through the hole in the inner strut.

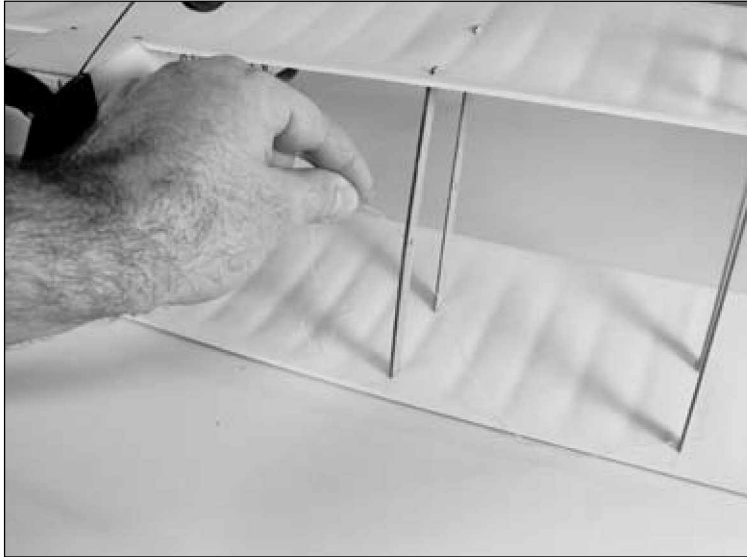

3. A tube has been installed in the fuselage to pass the rigging thread through to the opposite side of the fuselage.



4. The rigging thread goes through the hole in the inner strut then to the outer strut. Glue the thread to the strut using foam-safe CA.



5. Apply very light tension to the rigging thread and apply foam-safe CA to the thread to attach it to the strut. Use scissors to cut the rigging thread once the CA cures.



6. When installing the rigging from the bottom of the outer strut, the rigging will pass through holes in the cabane struts as shown.

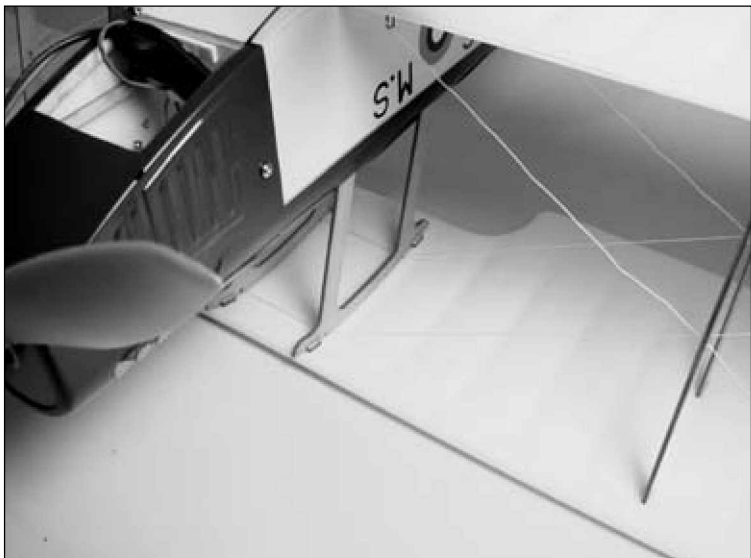

7. Complete the rigging installation because it looks great and adds realism to your model.



## Control Throws

1. Turn on the transmitter and receiver of your aircraft. Check the movement of the rudder using the transmitter. When the stick is moved right, the rudder should also move right. Reverse the direction of the servo at the transmitter if necessary.

2. Check the movement of the elevator with the radio system. Moving the elevator stick down will make the airplane elevator move up.

### *Elevator*

High Rate:  $1\frac{1}{4}$ -inch (32mm) up/down

Low Rate:  $\frac{7}{8}$ -inch (22mm) up/down

### *Rudder*

High Rate: 2-inch (51mm) left/right

Low Rate:  $1\frac{1}{8}$ -inch (38mm) left/right

## Center of Gravity

An important part of preparing the aircraft for flight is properly balancing the model.

*Caution: Do not inadvertently skip this step!*

The recommended Center of Gravity (CG) location is 2-inches (51mm) behind the leading edge of the top wing against the cabane struts. Model is balanced in an upright position.

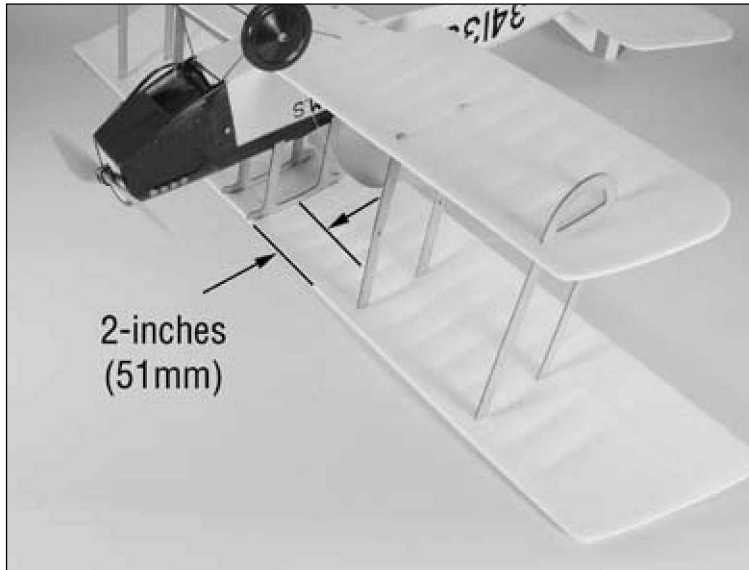

## Range Test Your Radio

1. Before each flying session, be sure to range check your radio. This is accomplished by turning on your transmitter with the antenna collapsed. Turn on the receiver in your airplane. With your airplane on the ground and the engine running, you should be able to walk 30 paces (approximately 100 feet) away from your airplane and still have complete control of all functions.

If not, don't attempt to fly! Have your radio equipment checked out by the manufacturer.

2. Double-check that all controls (aileron, elevator, rudder and throttle) move in the correct direction.

3. Be sure that your transmitter batteries are fully charged, per the instructions included with your radio.

## Preflight

---

### *Check Your Radio*

Before going to the field, be sure that your batteries are fully charged per the instructions included with your radio. Charge both the transmitter and receiver pack for your airplane. Use the recommended charger supplied with your particular radio system, following the instructions provided with the radio. In most cases, the radio should be charged the night before going out flying.

Before each flying session, be sure to range check your radio. See your radio manual for the recommended range and instructions for your radio system. Each radio manufacturer specifies different procedures for their radio systems. Next, start the motor. With the model securely anchored, check the range again. The range test should not be significantly affected. If it is, don't attempt to fly! Have your radio equipment checked out by the manufacturer.

*Note:* Keep loose items that can get entangled in the propeller away from the prop. These include loose clothing, or other objects such as pencils and screwdrivers. Especially keep your hands away from the propeller.

Double-check that all controls (aileron, elevator, rudder and throttle) move in the correct direction.

Check the radio installation and make sure all the control surfaces are moving correctly (i.e. the correct direction and with the recommended throws). Test run the motor and make sure it transitions smoothly from off to full throttle and back. Also ensure the engine is installed according to the manufacturer's instructions, and it will operate consistently.

Check all the control horns, servo horns, and clevises to make sure they are secure and in good condition. Replace any items that would be considered questionable. Failure of any of these components in flight would mean the loss of your aircraft.

## Flying the Jenny JN-4 Slow Flyer

---

You will find the Jenny JN-4 Slow Flyer to be a solid, honest-flying model.

Ensure your CG is set according to the manual and power up the aircraft. Move your throttle trim up slowly until the motor just begins to spin. This will be your flight idle that will help to establish a longer glide path and tends to make landings easier. Before taxiing out to the runway, double-check all controls are working in the correct direction and functioning properly. You will find the rudder very effective; on the ground, tracking is very predictable. Apply power smoothly and begin the takeoff roll. Correct with rudder as necessary and apply up elevator slowly until the model lifts off.

*Note:* Please do not attempt to perform any aerobatic maneuvers with your Jenny unless you have rigged the model with the string as outlined in this manual on page 20. The string rigging is required for loops, wing overs and other mild aerobatic maneuvers to ensure airframe strength and longevity.

You will find flying the Jenny to be very relaxing and easy. The model is not designed for high banked turns or high speed flight. Most flight is accomplished below half throttle and will yield flights in excess of 15 minutes with a 480 2-cell battery with a Park 250 when outfitted with the GWS 6x5 slow flyer prop. Landing the Jenny JN-4 Slow Flyer is as easy as setting up on final approach, lowering the throttle to idle and gliding in to a soft touch-down.

We hope you enjoy the experience of flying the Jenny JN-4 Slow Flyer.

Happy landings.

# 2007 Official AMA National

## Model Aircraft Safety Code

### GENERAL

- 1) I will not fly my model aircraft in sanctioned events, air shows or model flying demonstrations until it has been proven to be airworthy by having been previously, successfully flight tested.
- 2) I will not fly my model higher than approximately 400 feet within 3 miles of an airport without notifying the airport operator. I will give right-of-way and avoid flying in the proximity of full-scale aircraft. Where necessary, an observer shall be utilized to supervise flying to avoid having models fly in the proximity of full-scale aircraft.
- 3) Where established, I will abide by the safety rules for the flying site I use, and I will not willfully or deliberately fly my models in a careless, reckless and/or dangerous manner.
- 4) The maximum takeoff weight of a model is 55 pounds, except models flown under Experimental Aircraft rules.
- 5) I will not fly my model unless it is identified with my name and address or AMA number on or in the model. (This does not apply to models while being flown indoors.)
- 6) I will not operate models with metal-bladed propellers or with gaseous boosts, in which gases other than air enter their internal combustion engine(s); nor will I operate models with extremely hazardous fuels such as those containing tetranitromethane or hydrazine.

### RADIO CONTROL

- 1) I will have completed a successful radio equipment ground range check before the first flight of a new or repaired model.
- 2) I will not fly my model aircraft in the presence of spectators until I become a qualified flier, unless assisted by an experienced helper.
- 3) At all flying sites a straight or curved line(s) must be established in front of which all flying takes place with the other side for spectators. Only personnel involved with flying the aircraft are allowed at or in front of the flight line. Intentional flying behind the flight line is prohibited.

- 4) I will operate my model using only radio control frequencies currently allowed by the Federal Communications Commission. (Only properly licensed Amateurs are authorized to operate equipment on Amateur Band frequencies.)
- 5) Flying sites separated by three miles or more are considered safe from site-to-site interference, even when both sites use the same frequencies. Any circumstances under three miles separation require a frequency management arrangement, which may be either an allocation of specific frequencies for each site or testing to determine that freedom from interference exists. Allocation plans or interference test reports shall be signed by the parties involved and provided to AMA Headquarters.

Documents of agreement and reports may exist between (1) two or more AMA Chartered Clubs, (2) AMA clubs and individual AMA members not associated with AMA Clubs, or (3) two or more individual AMA members.

- 6) For Combat, distance between combat engagement line and spectator line will be 500 feet per cubic inch of engine displacement. (Example: .40 engine = 200 feet.); electric motors will be based on equivalent combustion engine size. Additional safety requirements will be per the RC Combat section of the current Competition Regulations.
- 7) At air shows or model flying demonstrations, a single straight line must be established, one side of which is for flying, with the other side for spectators.
- 8) With the exception of events flown under AMA Competition rules, after launch, except for pilots or helpers being used, no powered model may be flown closer than 25 feet to any person.
- 9) Under no circumstances may a pilot or other person touch a powered model in flight.







© 2007 Horizon Hobby, Inc.  
4105 Fieldstone Road  
Champaign, Illinois 61822  
(877) 504-0233  
*horizonhobby.com*  
*E-fliteRC.com*