

Congratulations...

On your purchase of the new Airwolf fuselage kit from Funky exclusively distributed by Century Helicopter Products. This high quality fuselage body kit is universal in nature to fit many of the current 30-46 helicopters. Items required to complete the fuselage include:

Required:

Slow CA Glue
Pencil & Ruler
1/16" Drill Bit
Regular Hand Tools
Masking Tape
1 1/2" Wheels (3)

Recommended Items:

Moto Tool w/ sanding drum
320 Grit Sandpaper
Paint & Primer (#4035)
30 Minute Epoxy
Retract Set (#CN30RET)
12" of 1/8" wire (non retractable)

Overall parts layout, photo shows painted fuselage.

Before starting, it has to be decided whether retractable or fixed landing gear is to be used. The wood parts included are for retractable landing gear. If fixed gear is installed, additional wood is required to secure the 1/8" wire.

Step 1

Locate, lightly sand and test fit the wooden parts for the side wing pods, note there is a left and right side. Mark and cut retract mount D & F as shown, make 2 pieces each. Use masking tape to temporarily hold the parts as shown. When viewing the pods from the end, make sure the retract mounts (D & F) are set 90 degrees to former A and butt against former E. When all parts are positioned correctly, tack glue in place using a few drops of CA type glue. Remove the masking tape and permanently glue all joints.

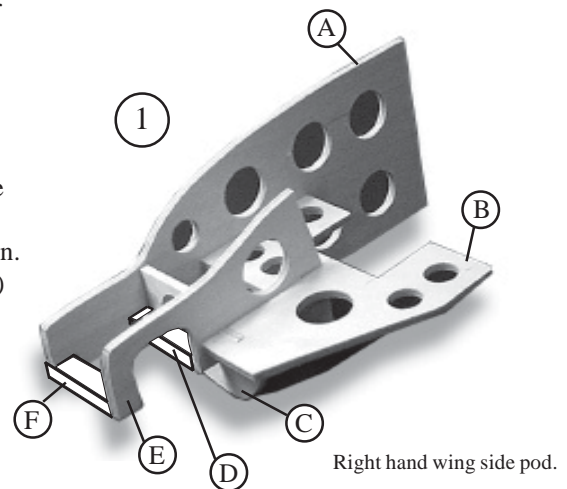
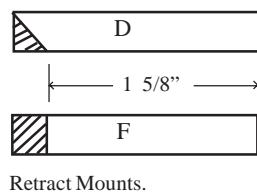
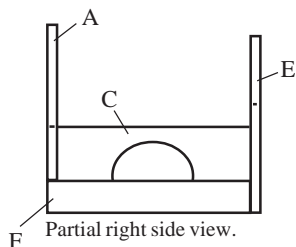

Step 2

Locate, lightly sand and test fit the wooden parts for the front pod. Use masking tape to temporarily hold the parts, make sure the retract mount (J) are set 90 degrees to former K. When all parts are positioned correctly, tack glue in place using a few drops of CA type glue. Remove the masking tape and permanently glue all joints.

Now that the 3 pods are assembled it is recommended to fuel proof the wood parts using a fuel proof paint or the epoxy thinned down to a water consistency and painted using a disposable brush. Only a light coat is required, save as much weight as possible.

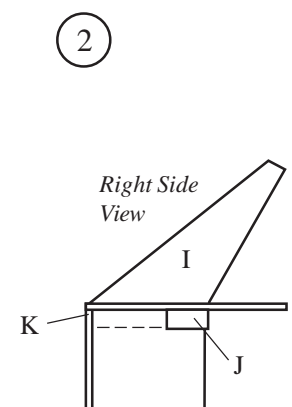
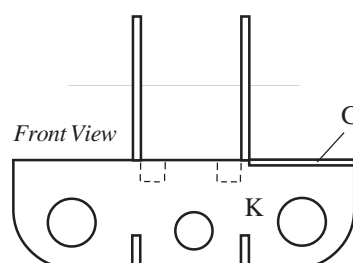
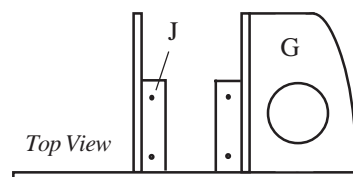

2

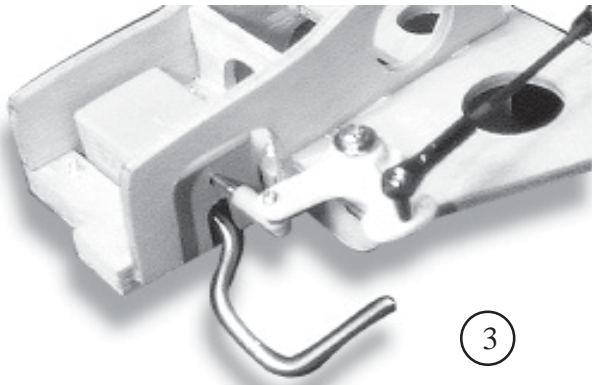

Step 3 Mark and drill 4 holes on the retract mounts using the retracts as guides. Drill through with the 1/16" drill as a pilot hole. Bend the wire gear as shown, the distance of the center of the wheel to the retract housing should be 1 1/4" when using 1 1/2" wheels on the side pods. Make the same bend for the front but leave the straight leg long for now (cut to length later to adjust sitting attitude). Mark and drill the pivot holes for the pod bellcranks and servo and install on each side pod. Take note that the side pod bellcranks require one arm cut off each corresponding side.

One or two servos can be used to drive the retracts (linkage in not included). Glue former L to former A on one side such that it overlaps the rear pod formers. Temporarily mount the pods into the fuselage aligning and secure formers A with a piece of tape. Using a ruler measure the distance between the front and rear pods. Remove the pods and reposition them out side the fuselage to setup the pushrod linkage. It is better to finalize all retract movement before bonding the pods into the fuselage. Please note that the wheels will not completely pull into the wings due to the layout of components.

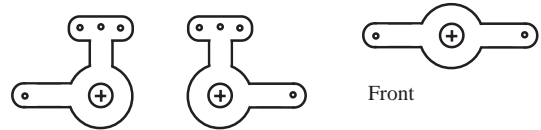
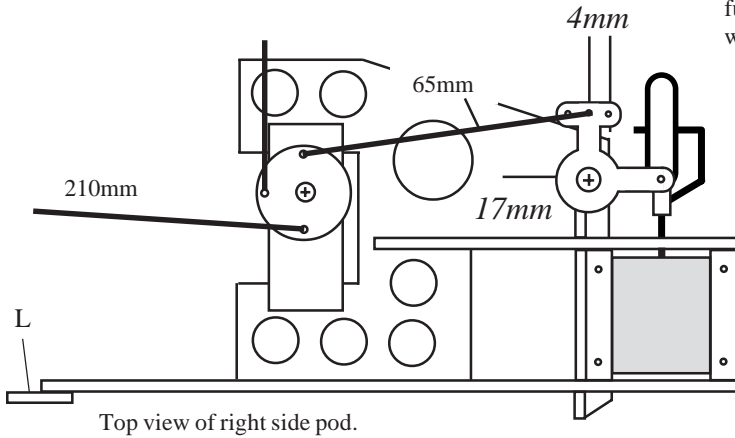

Trim off one arm when mounting to pods as shown.

The front retract can be activated by a long pushrod (1/4" balsa style or plastic Laser rod). The pushrod lengths shown are center of hole on the servo horn to center of hole on the bellcrank. Attach the retract pushrod to the bellcrank with one 2 x 8mm Phillips Machine Screw placing a hex nut in between (not included). Alternately, two servos can be mounted on each side pod connected by a "y" connector, attaching the front pod by the right side servo.

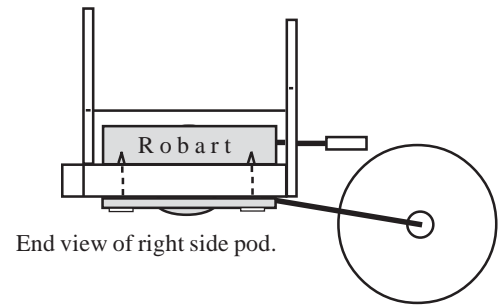

Step 4 The photo below shows the three completed pods ready to be installed into the fuselage. Note that the front landing gear wire is longer as the retract is mounted 1 1/4" above the bottom of the fuselage whereas the side retracts are only 1/4" above the bottom of the wings.

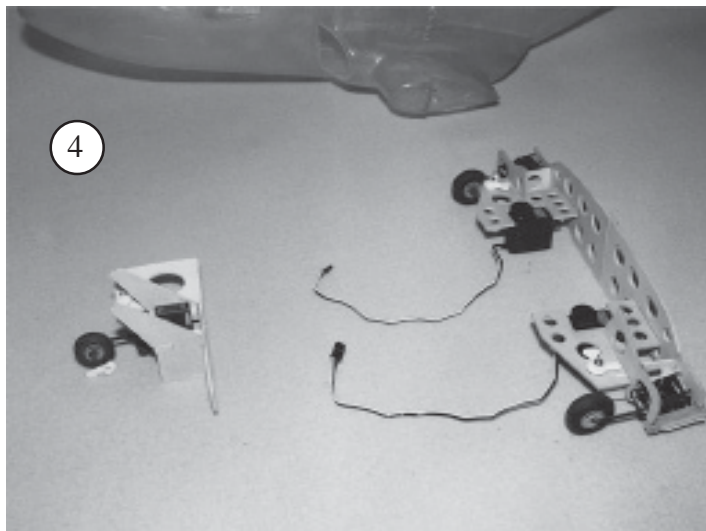

Step 5 Temporarily install the pods into the fuselage and tape in place, hold the fuse into a light and mark on the outside the openings to be cut out for the wheels and landing gear. Finally roughen the inside surfaces to provide a better bonding surface between the wood and the fiberglass. Use 30 Minute epoxy.

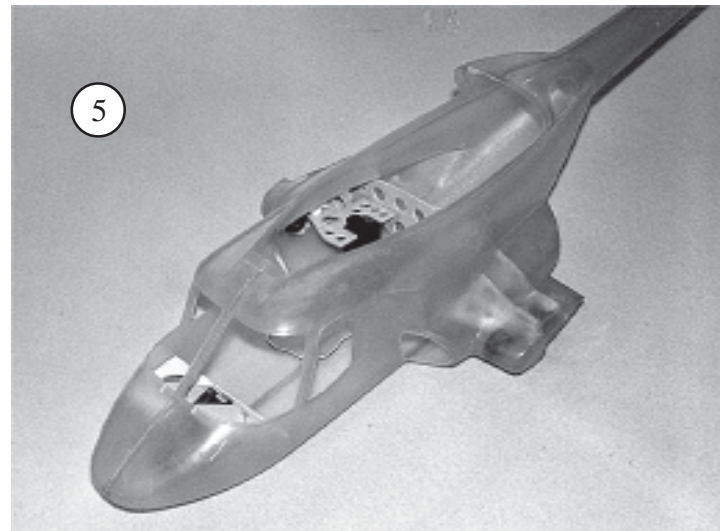

Disassemble the helicopter to be mounted into the fuselage, remove the head, tail boom and landing gear. Position the engine mechanics into the bottom floor and mark the 4 landing gear holes, install the top cap to align the main shaft in the center of the opening.

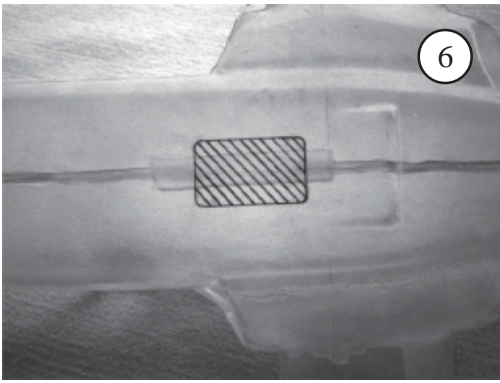

Step 6 Temporarily tape the mechanics into the bottom of the fuselage and mark the engine section, this area needs to be cut out to allow the engine fan to sufficiently cool the engine. We recommend an minimum opening of 2" wide by 3 1/2" long, large enough to get access to remove the glow plug and to connect the glow starter. With this marked, rough out the hole with a cut off wheel mounted to a mototool and clean up using the sanding drum (alternately, drill small holes near the corners and use a fine toothed saw, clean up with a file. Do not drill the landing gear holes until after the tail boom has been fitted.

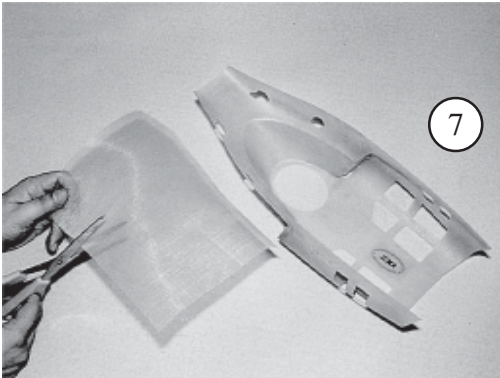

Step 7 Cut the mesh material into 3 major areas, two which fit over the entire 7 rear cooling vents per side and 4 tiny ones in the front. Overlap the openings by 1/2", tape the mesh in place at the corners and coat the mesh in CA type glue, this will bond the mesh to the fiberglass and will harden the mesh in the openings to become stiff to the touch. Remove the tape after the glue has dried.

Step 8 To install the scale exhaust deflectors, hold the part in place and mark the contour following the top cap hole. Sand the last portion which will fit inside the top cap. Tack the part in place with a few drops of CA glue, apply epoxy to the seam around the deflector. When this has dried, the seam can be blended into the top cap with fine sand paper.

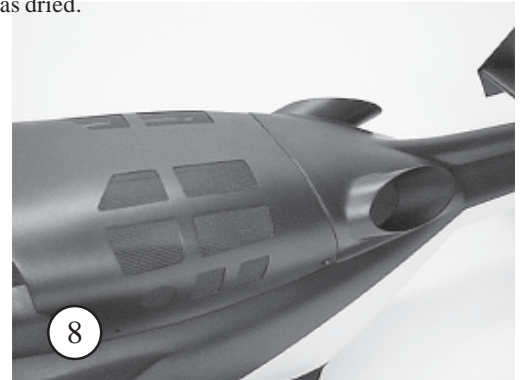

Molded Fiberglass Parts - Preparation for Assembly and Painting

The following assembly involves most of the smaller fiberglass parts, after removing them from the plastic bags, wash is warm water with a mild detergent. This will remove any remaining mold release agent. Lightly sand each part to smooth the edges and remove any extra flash produced from the molds. On the guns, remove the seam and carefully cut the mounts from the fiberglass sheet they are attached to. Also be carefull on the ends of the gun mounts as they are fitted to holes in the end of the wings and the wing caps, too much sanding will make a loose fit and prove difficult to bond later.

Step 9 Hold the nose piece on the front of the body and mark a line around it. Roughen the mating surfaces with sand paper and bond permanently in place.

Step 10 Tape the top cap to the body and make four equally spaced marks across both parts where the screws will be placed. Measuring 1/4" from the bottom edge of the top cap mark and drill all eight 1/16" holes, make sure the hole goes through both cap and body. Roughen one side of the 3/8" square blocks and the inside surface around the hole on the main fuselage. Bond all blocks to the fiberglass, once dry, re-drill through the wood blocks.

Step 11 Glue the single and twin guns to their mounts on a flat surface. Test fit and glue the gun assemblies to the wing cap, note that the top of the cap is wider than the bottom. Attach **without glue** to the body to make sure the gun mounts are aligned properly. Tape in place until dry, set aside for painting. Test fit the retract wood parts and check that the wood formers do not interfere with the pods, some trimming may be required.

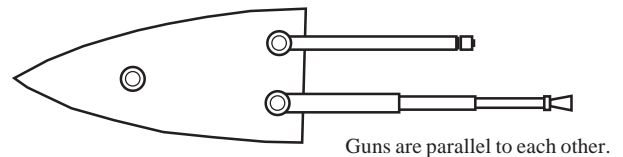
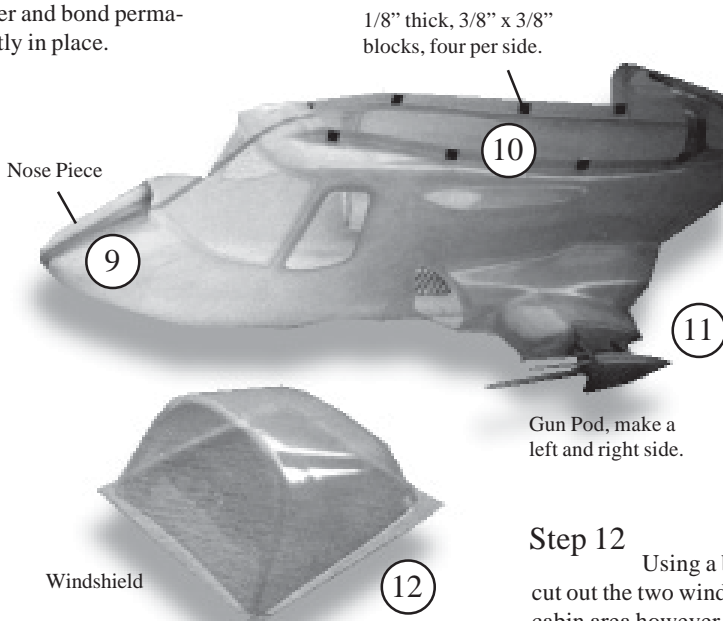
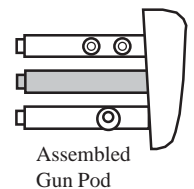

Step 12

Using a black marker, trace the scribe line in the windshield. Using scissors cut out the two windshield halves. We recommend that the windshield be bonded to the cabin area however if screws are to be used (not included) they should be marked and drilled at this time. Button head #2 sheet metal screws work well for this. Tape the windshield to the cabin, mark 4-6 locations per side and make 1/16" holes.

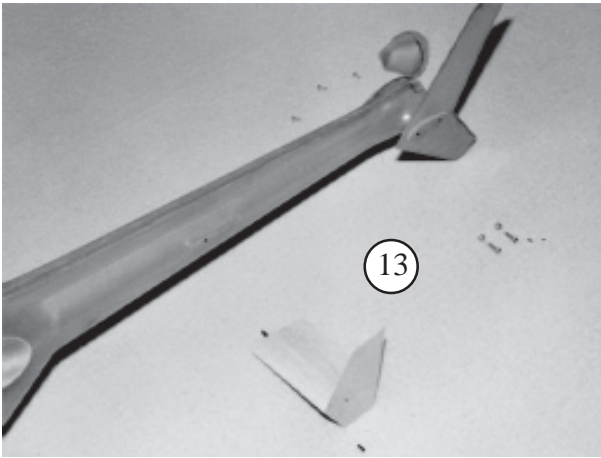

Step 13 Mark a line on the plywood fin parallel to the top edge, aligned with the front pointed edge, mark and drill two 1/16" holes through both fins (make a left and right side with the flat side of the stabilizer facing upwards). Using the fin as a template, drill into the balsa stabilizer fin about 1/4" deep. Soak the hole in the balsa fin with CA glue to harden the wood. Match the stabilizer to the molded tail section and draw a pencil line at 1/3 from the leading edge of the stab. Drill a 1/16" hole into the center of the thickest portion in 3/4" from the end. This is for the threaded rod, soak the hole with CA glue, when dry thread the rod in. Drill a hole in the fuselage, this is only for alignment. Once painted glue the fin to the body.

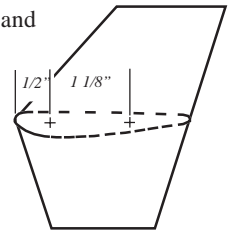

Step 14 Tape the tail end cap to the body and make three equally spaced marks across both parts where the screws will be placed as shown in the picture. Measuring 1/4" from the bottom edge of the top cap mark and drill 1/16" holes, make sure the hole goes through both cap and body. Roughen one side of the 3/8" square blocks and the inside surface around the hole on the main fuselage. Bond all blocks to the fiberglass, once dry, re-drill through the wood blocks. For the vertical fin, note the shorter side goes down, mark and drill two holes through the fin and glue two wood blocks on the inside following the same process. Install the tail boom with gearbox and reattach with the mechanics moved far back, cut a slot for the tail output shaft until the main shaft is again centered in the hole in the top cap and the landing gear bolts are aligned with the marks made previously. Finish the hole around the tail output shaft including the tail pitch plate and bellcrank, you may need to trim the cap through the joint. Finally, reattach your mechanics before painting to ensure all controls are working without touching the body, some trimming may be required.

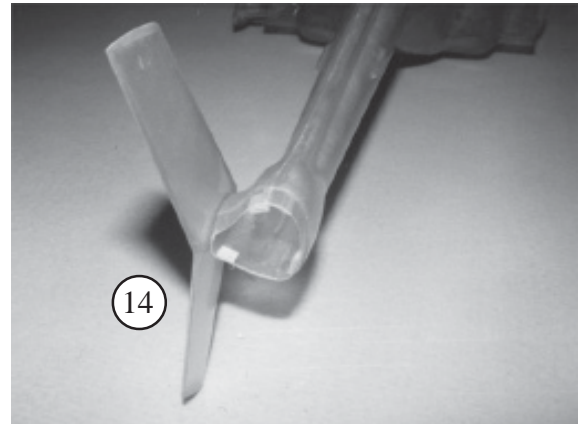

Step 15 This is a reminder just prior to starting the prep work for the painting the fuselage. Recheck all areas that need to be glued or fastened after the paint has been applied, make sure the gun pods will fit into the mating fuselage holes.

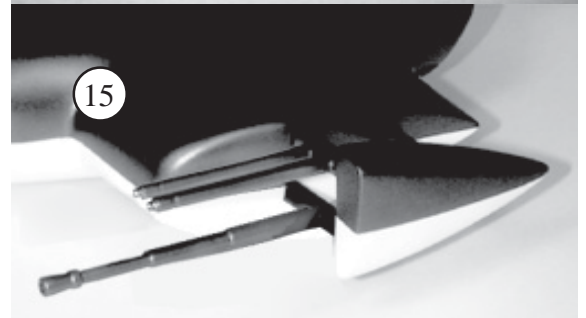

Step 16 To prepare the fuselage for painting, wash the fuselage with warm water and mild detergent and let dry (to remove any mold release wax). Sand the entire body lightly with #320 grit sand paper and wipe clean to provide good adhesion between the paint and the fiberglass surface. The fuselage should be primed before any paint is applied, the primer will show any areas requiring filling, especially at the exhausts. Automotive spot putty works well to fill and shape small areas. Continue priming with thin coats while sanding in-between with finer sand paper until

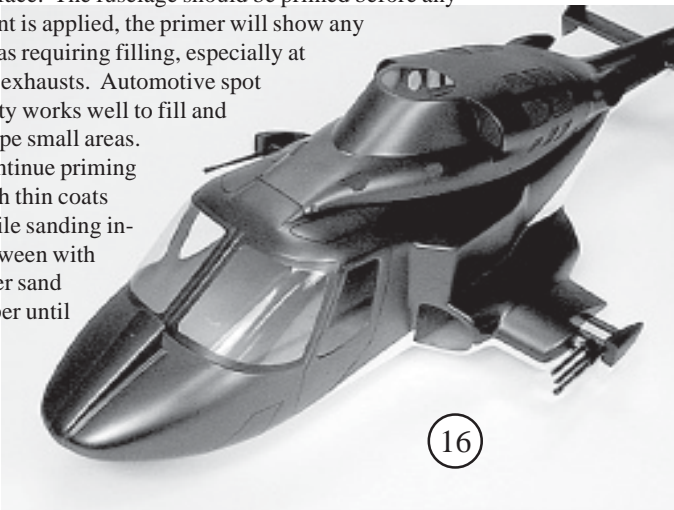

Step 17

The final detailing in the picture was done using 1/16" black pinstripping tape to outline the pilot doors, roof and floor windows (painted in) and panel lines. Applied last is a clear fuel proof coat to seal the pinstripes and fuel proof the body. Pactra makes a good clear polyurethane for this which is compatible with most paints**.

**Please check all paint on scrap material first for compatibility. As a final note, holes cut after painting (exhaust pipe) should be sealed with a fuel proof paint.

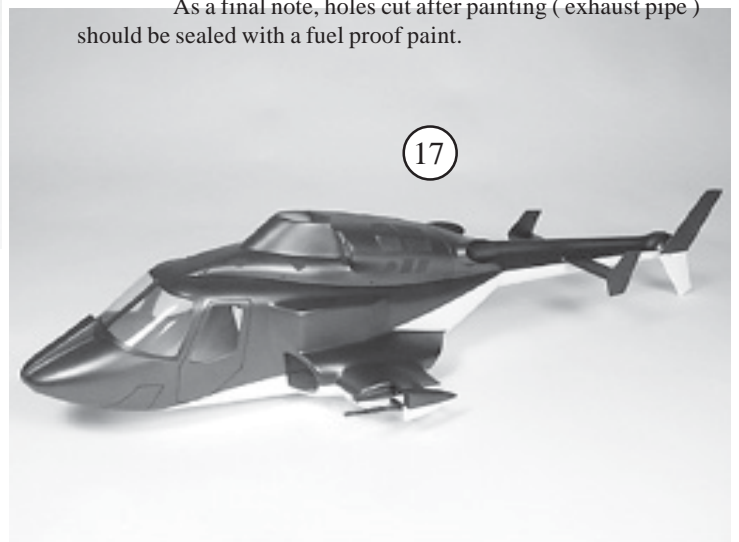

Airwolf Paint Scheme

Fuselage top: Metallic Gun Metal
 Fuselage bottom: White
 Machine Guns: Gun Metal or Silver

For final balancing, while holding the helicopter by the flybar close to the head the model shown be slightly nose heavy, the center of gravity should be 1/2" forward of the main shaft. If you have any questions regarding assembly, feel free to contact us here at Century at 408-451-1155.