

Joker



By Canterbury Sailplanes

Thank you for buying the Joker. This is a neat new model designed for 3D electric flight –it is light and very agile, and really fun to fly both indoor and outside. We hope you enjoy building and flying it!

Thanks to Brett Cudby and Sean McCurrie for their assistance with the design and testing of the Joker.

The Joker is designed with the GWS 350 motor and gear box (GW/EPS-350C with B, C or D gear box) 10x5 prop and 2 or 3 cell Lithium Polymer (li-pol) cells in mind. With this low cost combination it flies really well and will hover at around half throttle and complete the range of 3D maneuvers. Alternatively you can hot the motor up to a brushless out runner type motor – reducing the weight and increasing the power for an even hotter model!

Keeping the weight as light as possible is the key to 3D aerobatics – the Joker with the GWS motor and light weight radio gear, plus 2- 3 cell lipols should weigh 260 to 320gms. There is a lot you can do to keep the weight as light as possible.

Choose light radio equipment, some examples are;

- 3 cell Li-pol 850mah are ideal but the joker will fly on anything from 350-1500 mah - remember, the lighter your plane the better it will fly. You should get around 15min of hovering from an 850mah pack. Make sure the batteries have a good 'C' rating. This is an indication of how fast they can be charged and discharged. More than 5C is essential.
- 3 Servos; GWS Pico (5.4gm) and Hitec HS50 (6.1gm)
- Receivers GWS R-4PII (4.4gm) or Hitec Feather 7.8gm
- Electronic Speed controller (ESC); just about any 15Amp ESC will work well. EG GWS 15C or Wattage ISC15. There are special programmable ESC's available for Li-pol batteries but we have found that a cheap and basic ESC works nearly as well. Be aware that the motor cut off voltage of an ESC designed for Nicads will be set to cut the motor at around 4Volts – too low for Li-pols. Again experience has shown that if you stop flying when the motor performance starts to reduce (as the battery flattens) and recharge the battery this will be fine. Note also that a special speed controller is required for a brushless motor.
- We recommend using Z bends for all the linkages to keep the weight down. For convenience you may also like to consider using adjustable linkages such as Dubro EZ Connectors, pictured here.





You will need the following to complete the model;

- **Cyano-acrilate (CA)** Both thin and medium
- **CA Kicker/Accelerator** – helps CA to set quickly
- **Gorilla glue** or similar RPA adhesive is recommended (but not essential) for gluing some fuselage parts as it bridges gaps better than CA and adds stiffness to the fuselage.
- **Knife** ‘snap off’ type knives are the best
- **Strapping tape**
- **Fine screw drivers** for servo screws
- **Point nose pliers**, for Z bends and cutting wire
- **Felt tip marker pen**
- **1.6mm drill bit**
- **50mm of self adhesive Velcro**

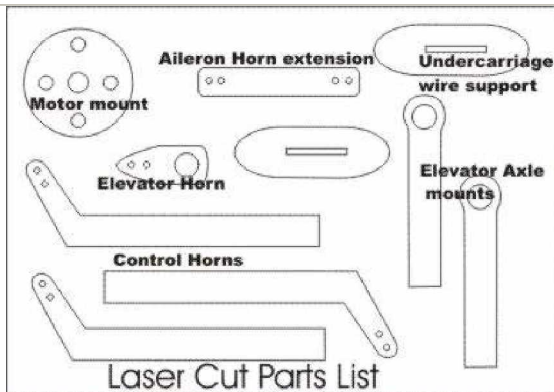

Wings	2	Rudder	1
Ailerons	2	Elevators	2
Fuselage parts	3	Control Pushrods	2 long 2 short
Plastic tube	1	Wheels	2
Laser cut plastic parts	1 set	Carbon fibre spar	1
Undercarriage wire	1		
6mm Carbon fibre elev' axle	1	GWS Motor mount	1



- Position the wings and fuselage fit together.
- The parts are cut as accurately as possible, however as some are cut on different days with varying humidity in the foam; it is possible for the parts to vary by 1-2mm. If necessary adjust the fit with a ruler and very sharp knife.



- Use Medium CA for most of the gluing on this model. You will also need 'kicker' to get the CA to 'go off' quickly.
- Apply kicker to the fuselage where the wings will glue on
- Apply CA along the edge of the wing.
- Slide the wing into the fuselage and hold for 10 seconds
- Repeat for the other wing

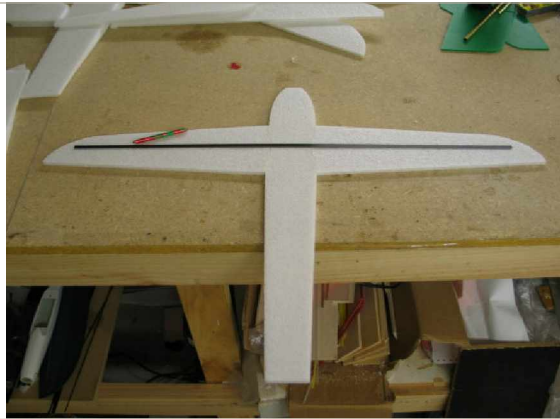

- Center the spar across the wing, so that the end of the spar is about 30mm from the front of the wing.
- Mark the position of each end of the spar
- Use a ruler to draw a line between these 2 points



- Use a ruler or straight edge to carefully cut a slot through the wing for the spar. Use a new sharp blade for this phase, to make sure the slot is straight and vertical



- Push the spar into the slot, start at one end and work along pushing it all the way into the slot.
- The spar is only slightly narrower than the wing so it should sit flush on both sides.



- Apply THIN CA along the spar line – it is likely to wick through and stick the wing to your bench, so lay some food wrap (glad wrap, cling film) under the wings!
- Spray on some kicker to set off the CA
- Turn the wing over and do the other side.



- Peel the paper backing off both sides of the two elevator axle mounts, and elevator horn and slide the parts onto the carbon elevator axle.
- Position the horn 100mm from the left end of the axle
- Secure the **horn only** with medium CA.

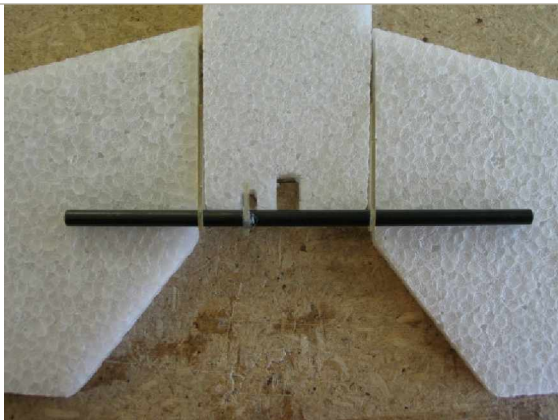

- Position the 2 tailplane halves under the axle with the rear of the axle 8 mm forward of the corner in the tailplane.

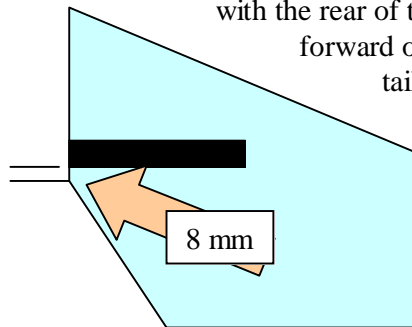

- Mark the location of the carbon tube on the tails.



- Cut out slots to suit the axle – make the slot just big enough to fit the carbon axle

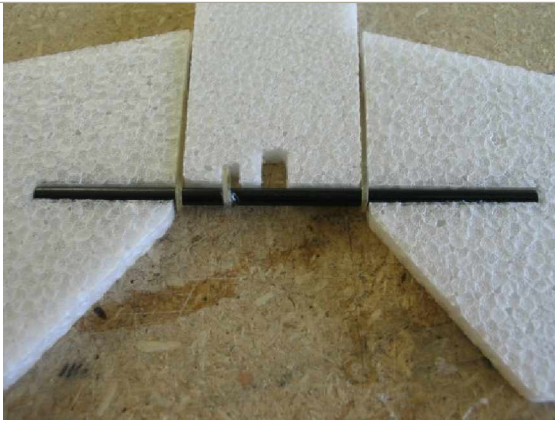

- Test fit the tails on the carbon rod. Make a small notch in the fuselage for the control horn (as shown in photo)
- Check that the fuselage is flat on the table, that the tailplane halves are flat, and the carbon tube parallel with the bench and the control horn pointing straight up

Be very careful in the next steps not to apply CA near where the axle passes thru the mounts as it won't move if it's stuck!!

- Use medium CA to glue the carbon rod in place in the tailplane halves
- Glue the Axle mounts to the fuselage sides
- Turn the model over and repeat on the other side

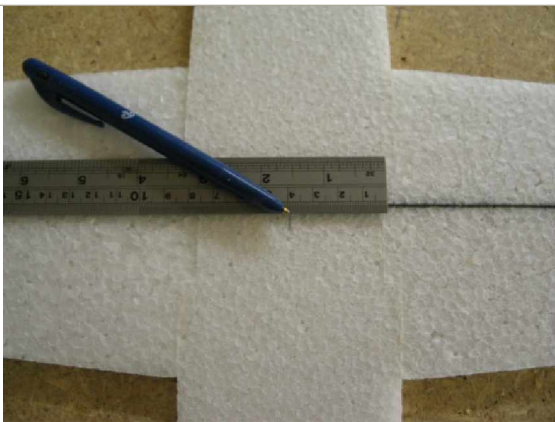

- Measure and mark the centre of the fuselage at the tail, nose and middle of the model
- Draw a line from nose to tail along the centre line



- Position the fuselage bottom piece over the main fuselage part.
- Mark and then cut the slot for the top and bottom fuselage parts to key into.
- If you are not really fussy about weight it is worth adding 50mm lengths of strapping tape at each corner, top and bottom where the wing meets the fuselage to prevent the epp tearing at these points in a hard crash.

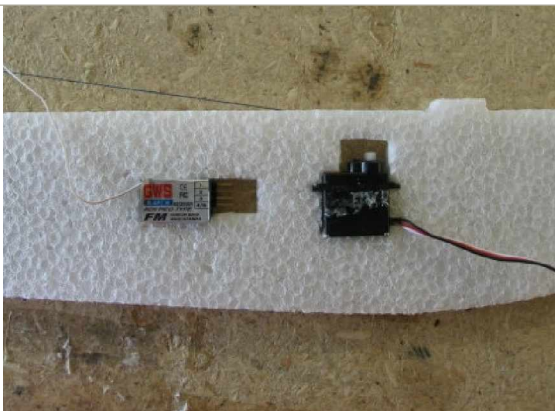

- The Aileron servo and receiver are fitted into the lower fuselage part, 10mm behind the notch in the top of this fuselage part. The top of the servo horn should be about 12mm from the top of the fuselage part. See photo for detail.
- Mark and cut the holes.
- Check the servo fit... but don't glue it in yet.

There are some options for installing the elevator and rudder servos;

1. Fit them into the skin just behind the spar as detailed below.
2. Glue them to the skin of the fuselage as far back on the model as the servo leads will allow.

Option 1 is tidier.

Option 2 is simpler and will enable the battery to be fitted closer to the centre of gravity.

Option 2.

If you are going for this option, delay fitting the elevator and rudder servos until the fuselage is completed. Simply workout how far the servos can be fitted from the receiver – but no closer than 150mm from the tail surfaces. Attach the servos to the underside of the horizontal fuselage part, with the servo horns close to the outer edge of the fuselage.

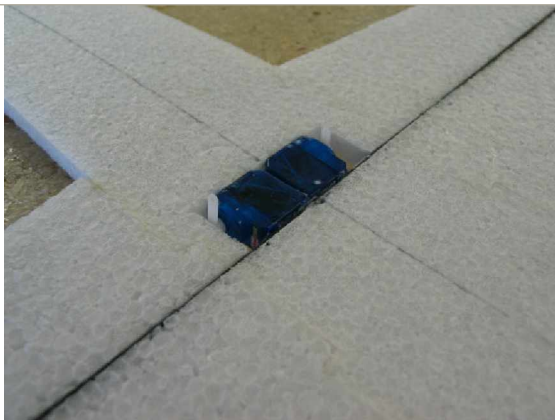

Option 1

- The Elevator and rudder servos are installed in the horizontal fuselage, just behind the spar. It is not necessary to cut off the servo mounting lugs.
 - Position the servos back to back with the wires toward the back of the model, and the forward edge of the servos touching the Spar.
 - Mark and cut the hole, this should be a tight fit – but not so tight it deforms the EPP around the hole.
 - Remove the screws and horns from the servos – check that there is enough space to replace the horns later – the screws are no longer required as the horns will remain in place without them.
 - Glue the servo in place with medium CA.
-
- If you are using a GWS motor, it needs to be mounted on the hardwood bearer provided.
 - Test fit the motor to the bearer and position on the underside of the fuselage, note from the photo that the rear edge of the motor case will be mounted about 10mm back from the front of the EPP. The underside is the side to which the elevator control horn is pointing!
 - Slide the motor off the wood



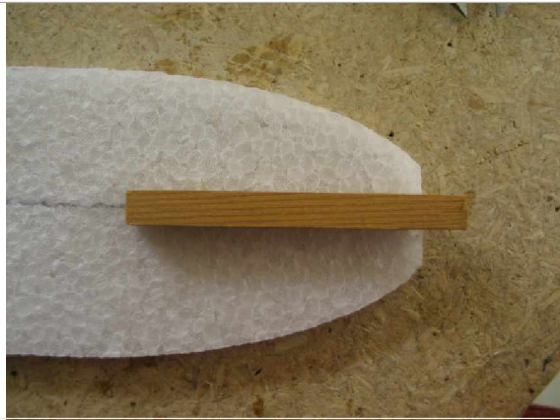

- Glue the block in place on the center line of the fuselage with Gorilla Glue or medium CA (gorilla glue is preferred) Keep the front 20mm free of glue so the motor mount can slide on.
- *The motor mount is set at 0 degrees (i.e. straight ahead) - not offset as is often the practice with electric flight, so the Joker will hover straight*



- Prepare the rudder hinge line by cutting the EPP edge at about 30 degrees – note the technique used in the photo and that I am cutting the left side.

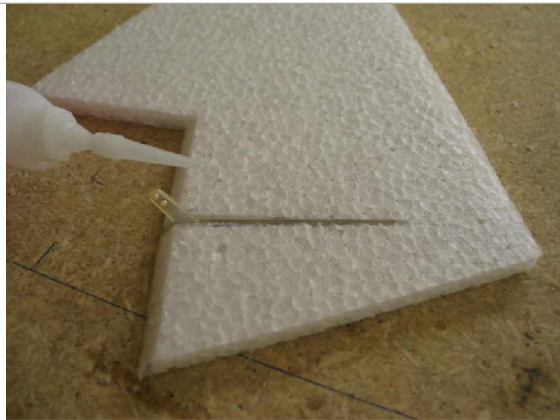

- Make a knife slot in the EPP for the rudder horn.
- Remove one horn from the sheet of polycarbonate parts, peel off the paper backing
- Scratch the surface of the horn where it will be glued with sand paper.
- Slide the horn into the EPP and secure by wicking thin CA into the slot from both sides and then apply kicker.



- In this step check that you make a left and right aileron by first positioning each behind the wing, mark one aileron as left on the bottom surface.
- The ailerons will be hinged on the top surface

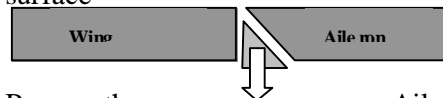

- Prepare the Ailerons for hinging by cutting the hinge line at 30 degrees. In the photo I am cutting from the bottom of the aileron for convenience.

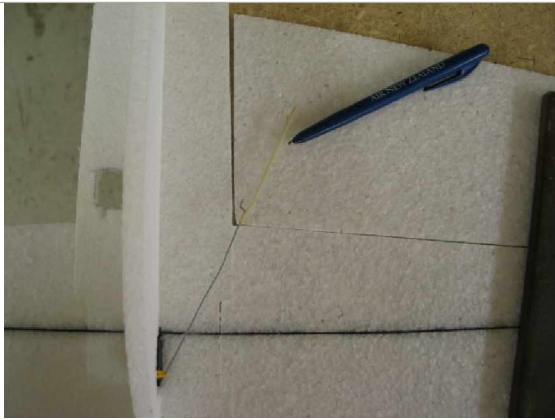

- Make a knife slot in the EPP for the Aileron horn. Note, as in the photo the horn will be located so it lines up with the pushrod wire from the servo – the wire is fitted in the photo to explain this point... you will fit yours a little later.
- Remove one horn from the sheet of polycarbonate parts, peel off the paper backing.
- Scratch the surface of the horn where it will be glued with sand paper.
- Slide the horn into the EPP slot and secure by wicking thin CA into the slot from both sides and then apply kicker.

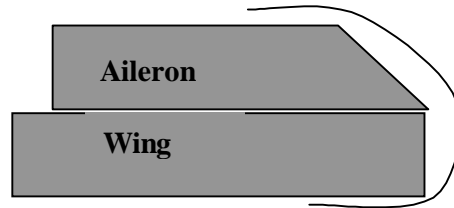

- Position the aileron on top of the wing.
- Create a hinge with a 50mm length of strapping tape wrapped around the trailing edge
- Repeat this in the centre and root of each wing



- Apply a length of strapping tape along the top of each aileron to complete the hinge.
- Use 20mm wide or less of strapping tape. If necessary simply cut wider tape down the middle to reduce the width and weight.

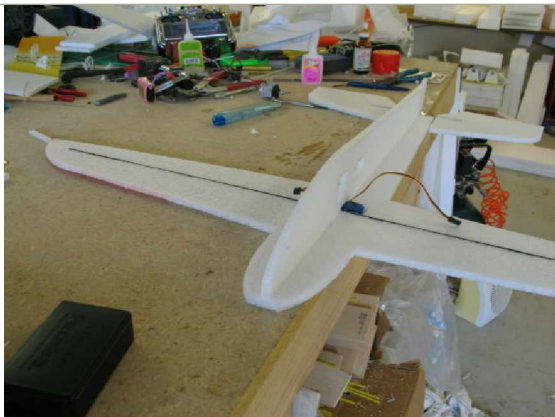

Attach the bottom part of the fuselage.

- If you are using the wood motor mount and a GWS motor, cut a slot in the front of the fuselage to suit.
- If you are not using the GWS motor and mount, the front end of the part must align accurately with the front of the main fuselage part so that when the motor mount is attached later it will fit correctly.
- When you are happy, glue the bottom part in place with gorilla glue or medium CA (gorilla glue is preferred)

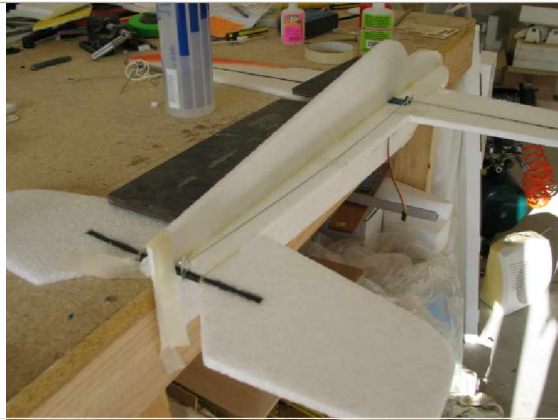

- Position the top fuselage piece on the fuselage. The front end must align accurately with the front of the main fuselage part so that when the motor mount is attached later it will fit correctly
- When your happy, glue the top part in place with gorilla glue



- Hinge the rudder to the fuselage in much the same way as the ailerons. Use 20mm wide tape on the right side and two short lengths on the left side.

The next step details the fitting of pushrods to the elevator and rudder servos. If you choose option 2 for fitting the servos, fit them now.

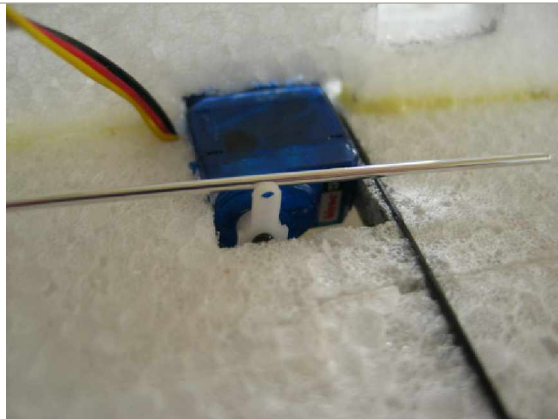

- Cut a 2 pieces of plastic tube 30mm long, slide one piece over the elevator pushrod wire -this will later act as a guide.
- Slip the pre z-bent end of the wire into the hole closest to the elevator axle.
- Lay the other end of the pushrod wire over the servo horn, accurately mark the point, and then make a Z bend. For info on making Z-bends see; <http://www.jkaerotech.com/Zbend.htm>
- Connect R/C gear and test the operation of the servo.
 - Make the Rudder pushrod. In the same manner as the elevator pushrod.
 - Tape the plastic guides to the fuselage approximately halfway between the servo and control surface.

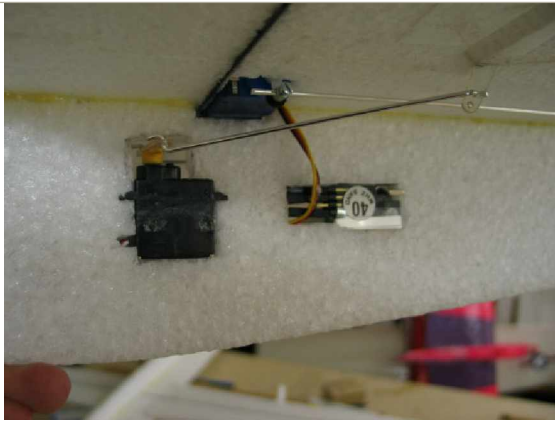

- Refit the aileron servo in place and secure with a small amount of CA.

Make linkages for the ailerons, one end of the wire is already Z bent.

- Remove the servo horn and CA the servo horn extension on top of it. It may be necessary to sand the top of the servo horn smooth to provide a flat surface to bond with the extension piece
- Check the length required and make Z bends in the wire. Slip both wires into their respective aileron horns, and then thread both the other ends onto the extended servo horn, then fit it to the servo.

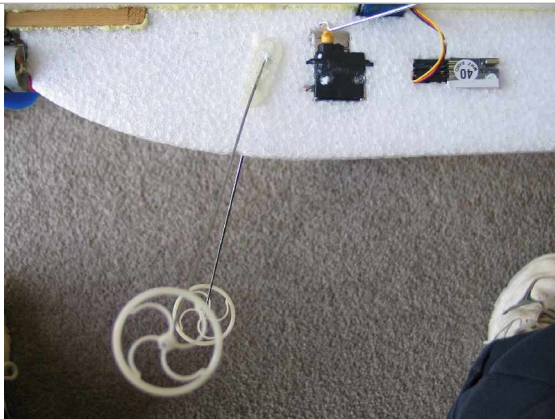

- Bend the undercarriage from the supplied wire, using the plan on the back page as a guide.
- Make a fine hole through the fuselage with a fine drill or screwdriver.
- Feed the U/C wire through
- CA in place
- Fit the covers over the wire and secure with medium CA.
- To fit the wheel to the undercarriage, cut 4 pieces of the plastic tube 3mm long. Slide one on to each side, secure with a drop of medium CA on the inside end of the tube, spray on kicker.
- Fit the wheels, and then slide on the tube. Secure with a drop of CA on the outside end of the wire (KEEP it clear of the wheel!) and spray on some kicker.

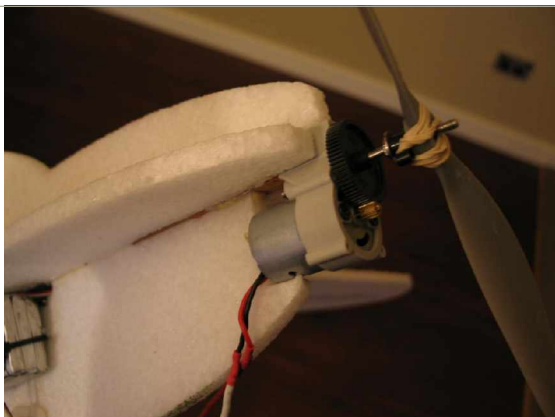

- Fit the motor
- Drill a hole thru the motor mount and into the wood, and then screw a small screw to hold the motor in place. A servo mounting screw is ideal for this.
- Use a prop saver as shown in this photo to increase the life of the prop. The prop sits on it, and is held in place with rubber bands.

-

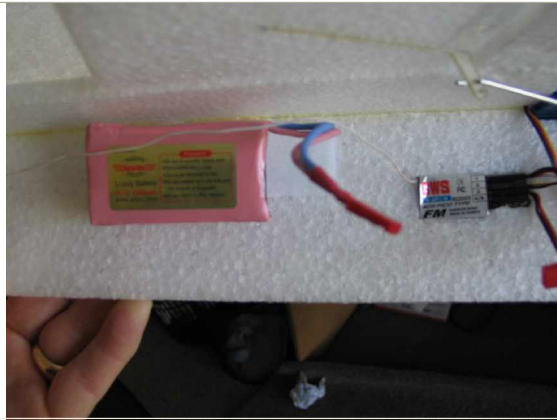

Fit the receiver

- Connect up the receiver, servos, speed controller etc
- Attach the battery with self adhesive Velcro



There is a range of Center of gravity positions to consider depending on the type of flying you intend.

For aerobatics and general fun flying balance the Joker just behind the spar.

For hovering balance the model at the aileron hinge line.

Adjust the balance by moving the battery forward or back until the model balances level.

Control movement

As much as you can get on all surfaces is good!!!!

Elevator – 45 degrees each way

Ailerons 30-40 degrees each way

Rudder 45 degrees each way

Joker wire undercarriage plan

