

Engine

76 Clutch Bell

1. Put adjusting shim onto the clutch bell after threading on the first pinion gear if needed.

Notice: Thread lock recommended for both pinion gears.

2. Slide one more adjusting shim onto the clutch bell and thread on second gear.

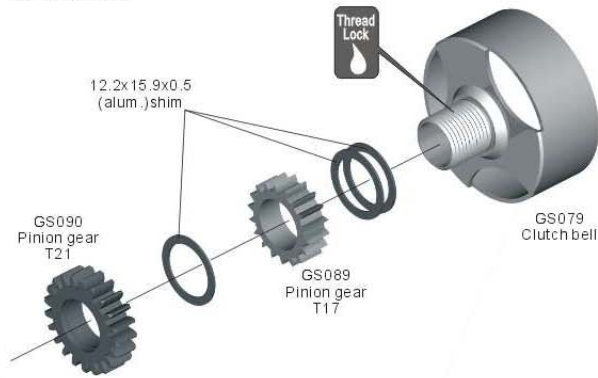

77 Clutch Bell

1. Press one 5x10x4 bearing into each side of the clutch bell.
2. Slide 5x7x0.2 shims onto the crankshaft followed by the clutch bell.
3. Secure with one 3x8 cap screw and washer.

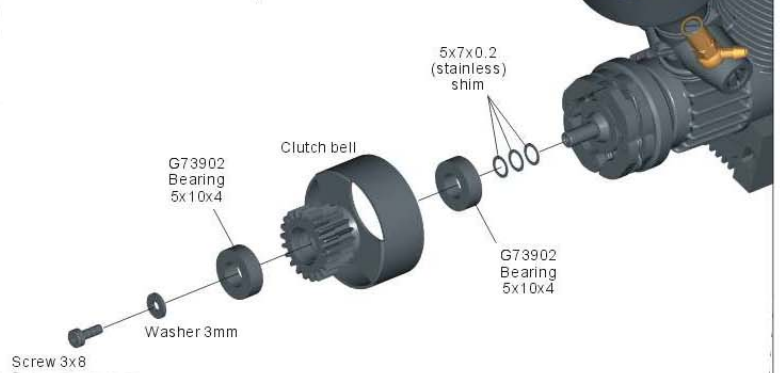

78 Muffler Pipe (GS080)

1. Assemble the muffler as shown in the diagram.
 2. Use four 3x12 button head screws to hole pipe together.
- Notice:* Thread lock recommended for these screws.
3. Thread in nipple with "O" ring into the front portion of the pipe.

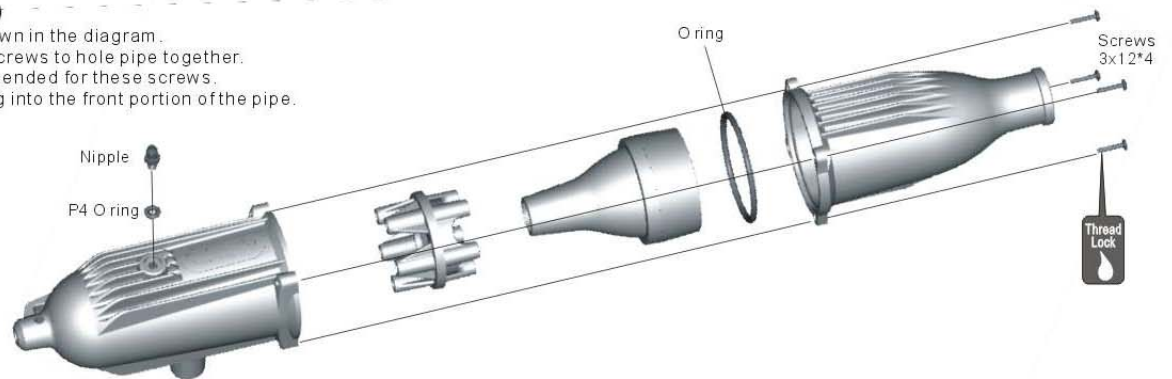

79 Air Filter

1. Press the foam filter into the rubber air filter mount.
2. Press entire air filter onto the carburetors air intake.

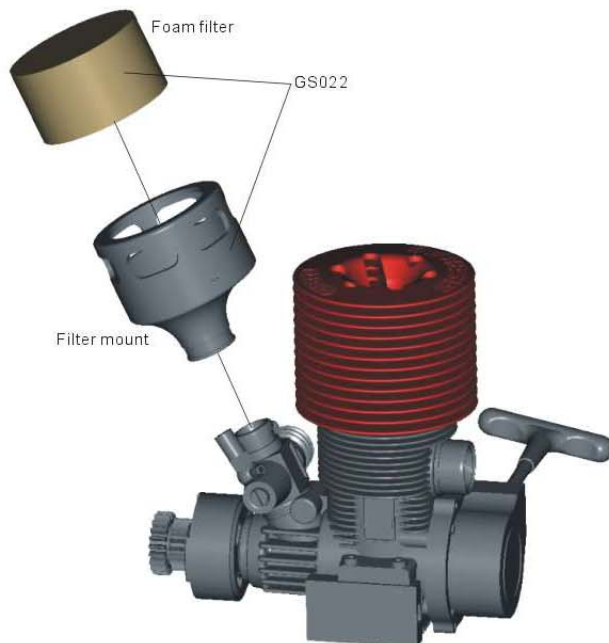

80 Muffler Pipe

1. Push the GS024 exhaust coupler onto the GS080 pipe.
2. Press the GS070 manifold into the GS024 exhaust coupler.
3. Secure using two FF068 medium zip ties. Trim off excess zip tie.
4. Press one exhaust gasket onto the engines exhaust port.
5. Gently press the manifold assembly onto the engine and secure using the supplied manifold spring.

Notice: The exhaust spring should wrap around the engine case not the carburetor.

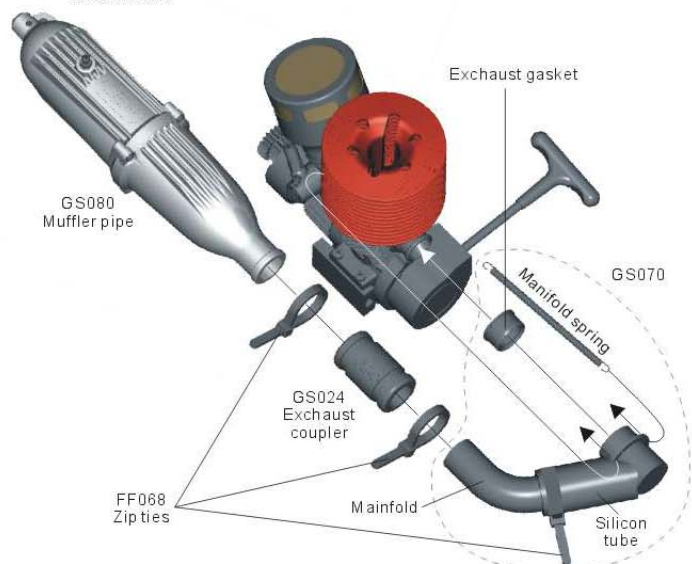

Front / Rear End

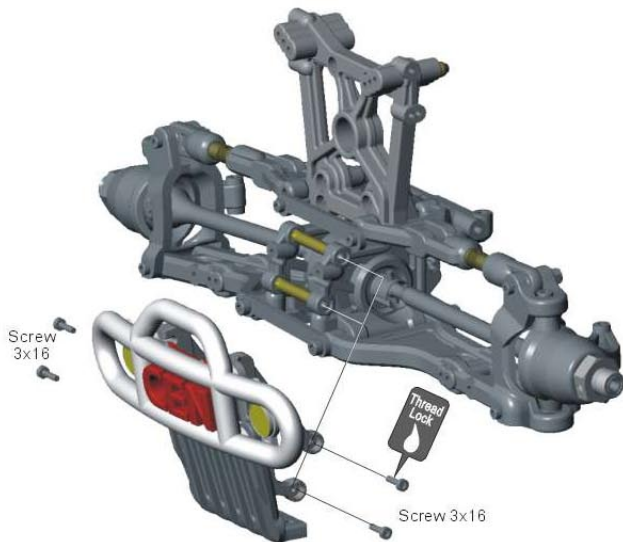

55 Front and Rear Bumper

1. Attach the front and rear bumper/skid plate assemblies using four 3x16 cap head screws.
- Notice:** Thread lock recommended for these screws.

56 Front and Rear Shocks

1. Press in one shock mount pivot ball into the upper and lower eyelets for each shock.
2. Attach two shocks to each suspension arm using two 3x52 screws and two 3mm lock nuts.

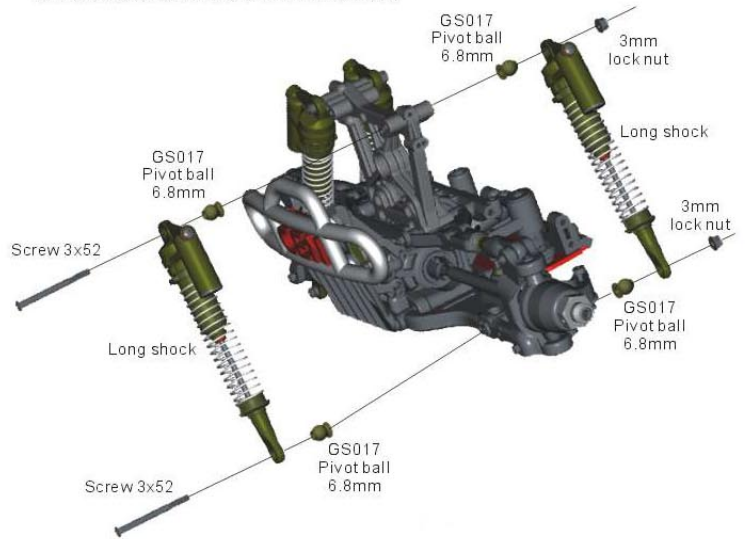

57 Lower Bracket x2

1. Mount one GS048 bracket onto front and rear GS059 bottom plates using three 4x12 flat head screws.

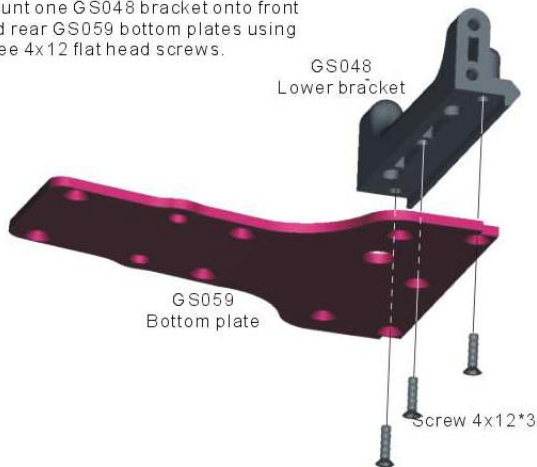

58 Servo Saver

1. Screw ball stud into the saver
2. Assemble the servo saver as shown. Make sure the hex on the GS019 is correctly seated.
3. Tighten the spring tension down until you have 6mm of threads exposed.

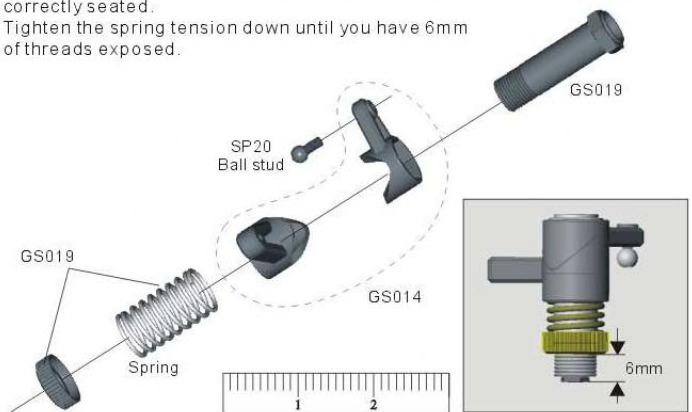

60 Servo Saver

1. Attach two GS019 steering posts onto the front bottom plate using two 4x12 flat head screws.
- Notice:** Thread lock is recommended for these screws.
2. Next put four G73917 bearings into the upper and lower bell cranks as shown in the picture.

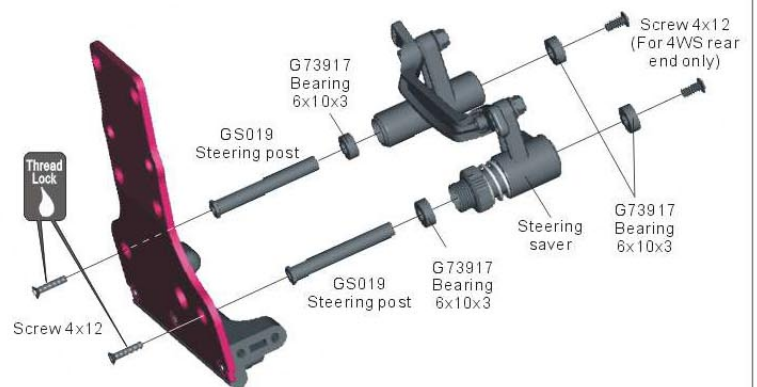

59 Steering Ball Crank

1. Attach the center link to each steering bell crank using 3x18 cap screws, two 3mm washers, two 3mm lock nuts and the GS012 #3 bushings. Double check you have the parts in the correct order as pictured.
2. Bell cranks should pivot freely. Loosen screws slightly if needed.

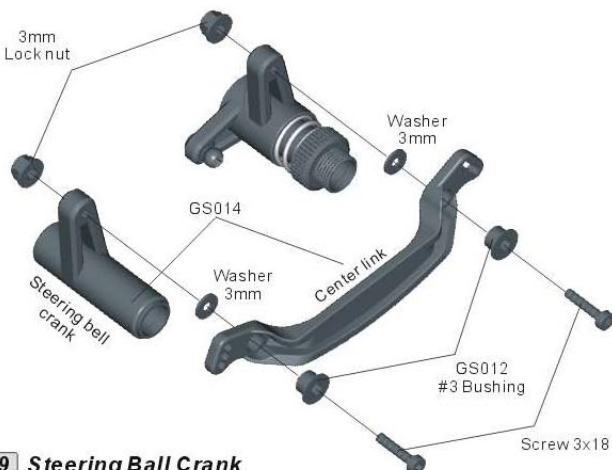

Front / Rear End

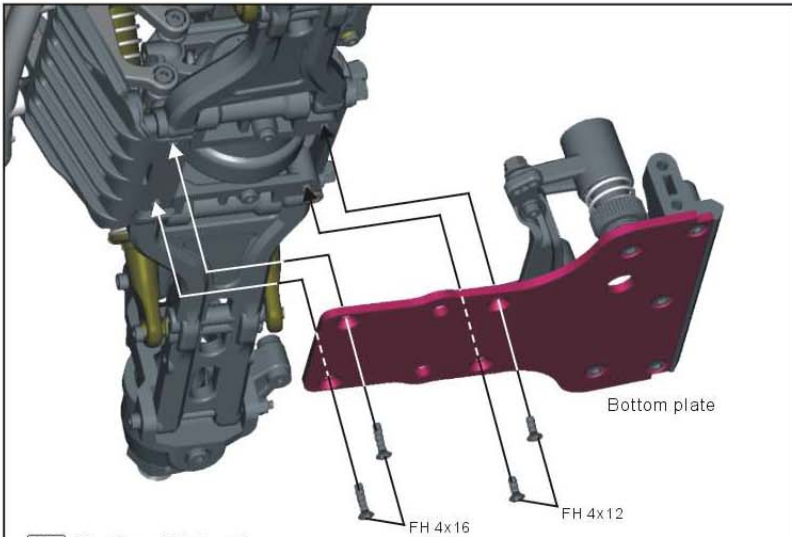

61 Bottom Plate x2

1. With the steering assembly mounted correctly onto the bottom plate, secure the entire end assembly onto the bottom plate using two 4x16 flat head screws and two 4x12 flat head screws.

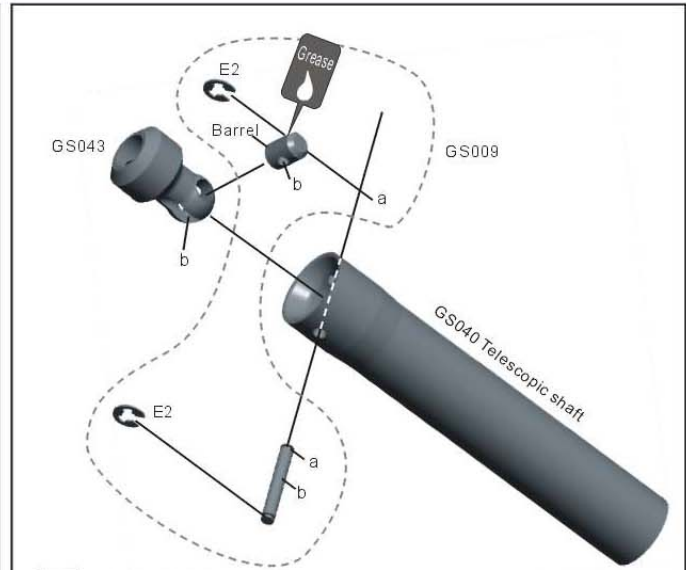

62 Center Drive Shaft

1. Apply a small amount of grease to the pivot barrel marked "b".

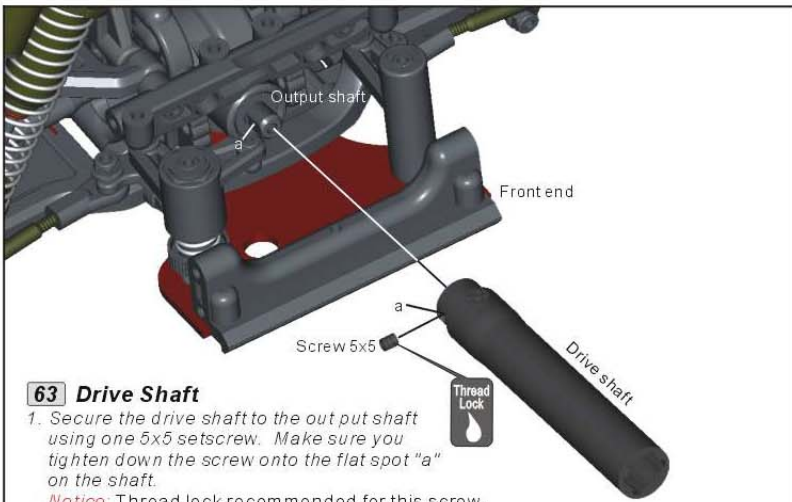

63 Drive Shaft

1. Secure the drive shaft to the out put shaft using one 5x5 setscrew. Make sure you tighten down the screw onto the flat spot "a" on the shaft.

Notice: Thread lock recommended for this screw.

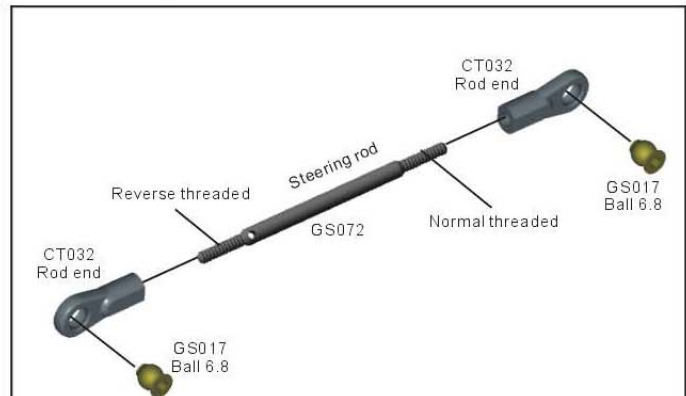

64 Steering Rod Assembly x2

1. Thread two CT032 into two GS072 steering rods.
2. Press in one pivot bushing (Ball 6.8) into each rod end.

Notice: Carefully look at the eyelet holes. Insert bushing into open side.

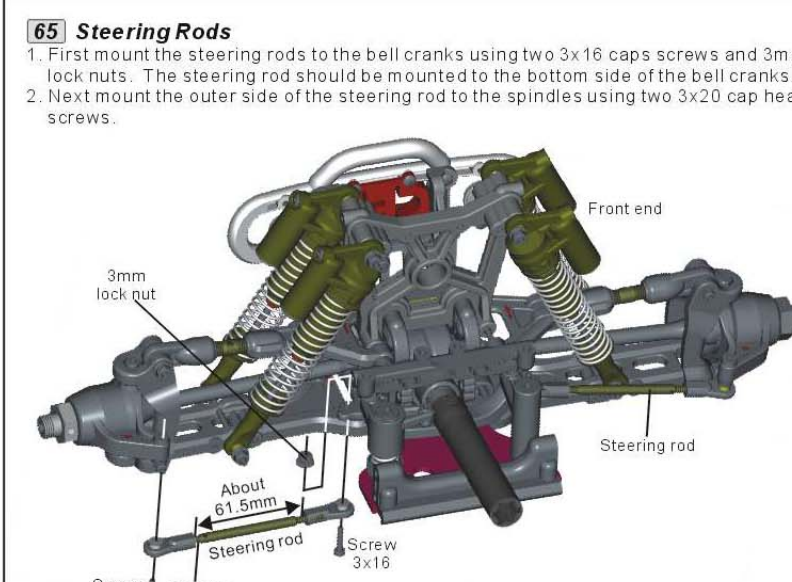

65 Steering Rods

1. First mount the steering rods to the bell cranks using two 3x16 caps screws and 3mm lock nuts. The steering rod should be mounted to the bottom side of the bell cranks.
2. Next mount the outer side of the steering rod to the spindles using two 3x20 cap head screws.

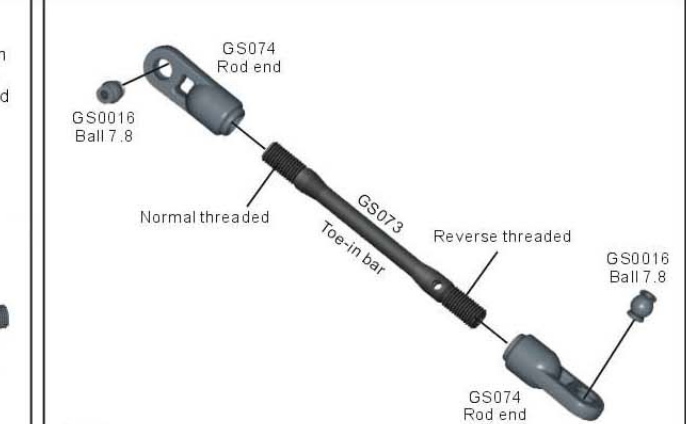

66 Toe-in Bar x2

1. Thread the GS074 rods ends onto the rear GS073 toe-in bars.
2. Press one GS016 pivot bushing into each rod end.

Notice: Carefully look at the eyelet holes. Insert bushing into open side.



Rear End

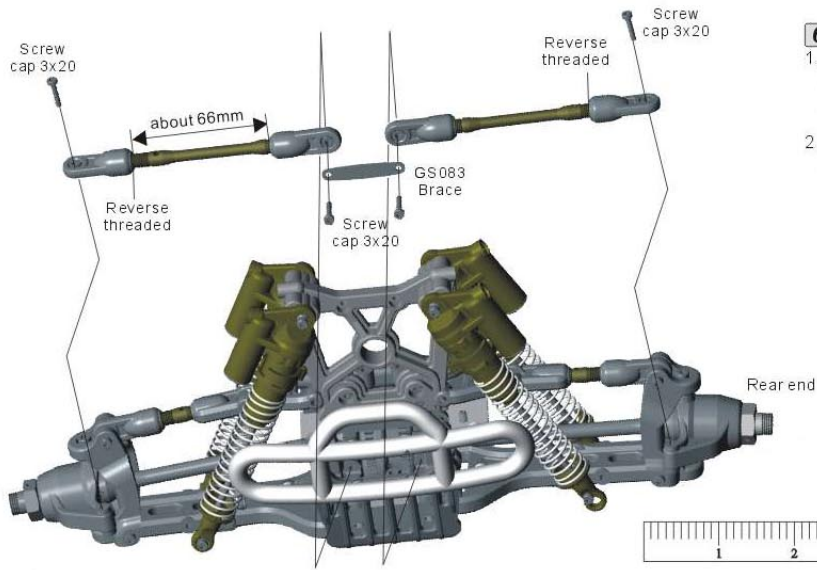

67 Toe-in Bar

1. Secure the toe-in bars with brace to the rear bulkhead using two 3x20 cap head screws.
Notice: Mount bars with adjusting hole on the outside for easier adjustment.
2. Secure the outer side of the bar to the rear spindle using two 3x20 cap head screws.

Radio Box

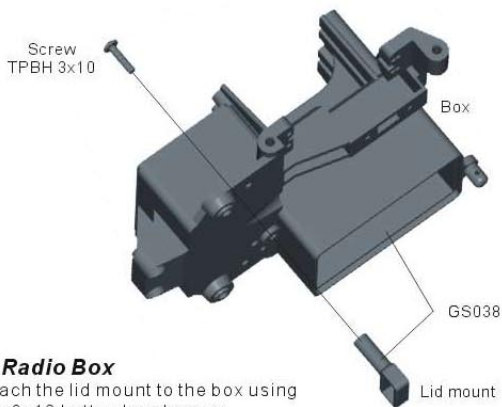

68 Radio Box

1. Attach the lid mount to the box using one 3x10 button head screw.

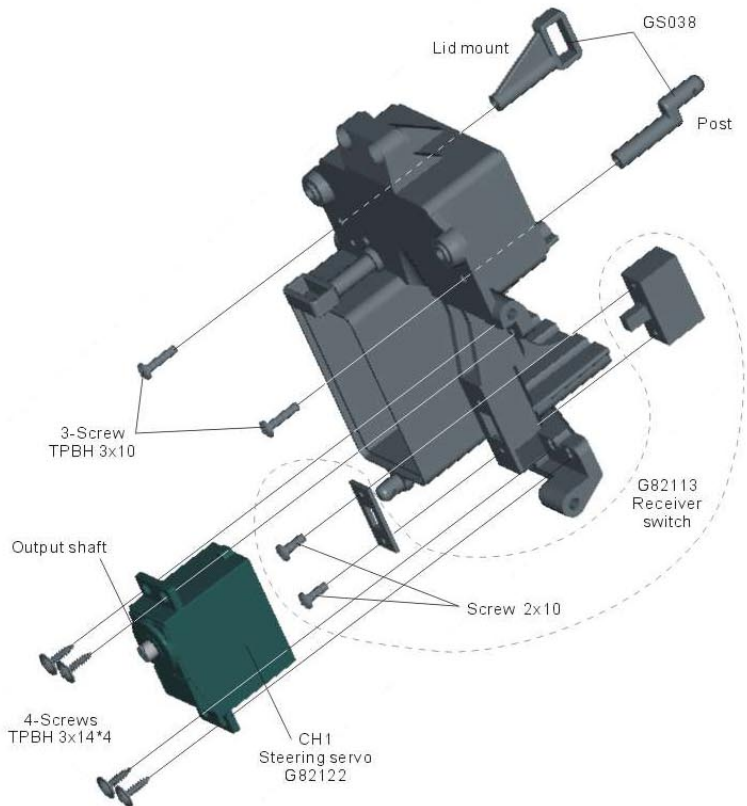

69 Steering Servo

1. Mount the second lid mount and post using two 3x10 button head screws.
2. Mount the G82113 on/off switch with plate using two 2x10 screws
3. Mount the G82122 steering servo to the underside of the radio box using four 3x14 screws.

Notice: Pay attention to the placement of the output shaft on the servo.

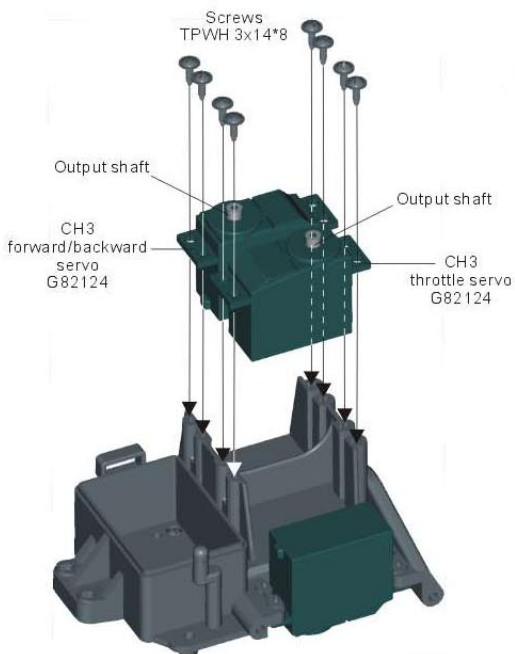

70 Servos

1. Mount two G82124 servos; throttle and auxiliary servo, to the upper side of the radio box using eight 3x14 screws.

Notice: Pay attention to the placement of each servos output shaft in the diagram

Radio Box

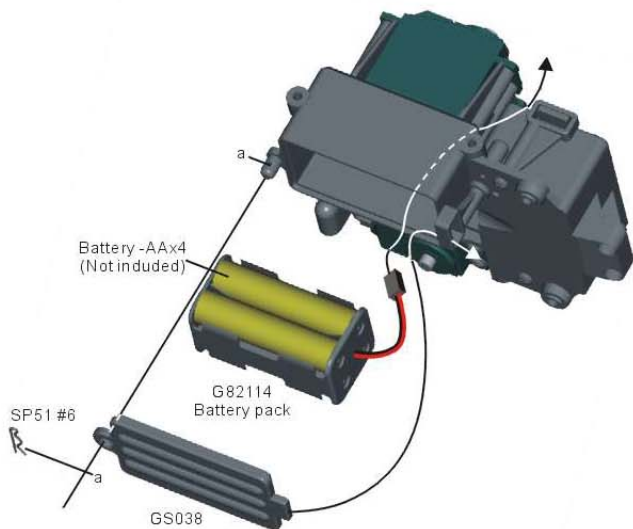

71 Battery Compartment

1. Install four fresh AA batteries into the G82114 battery pack.
2. Feed the plug through the outlet hole on the inside of the battery compartment.
3. Mount and secure GS038 compartment cover with one SP51 clip.

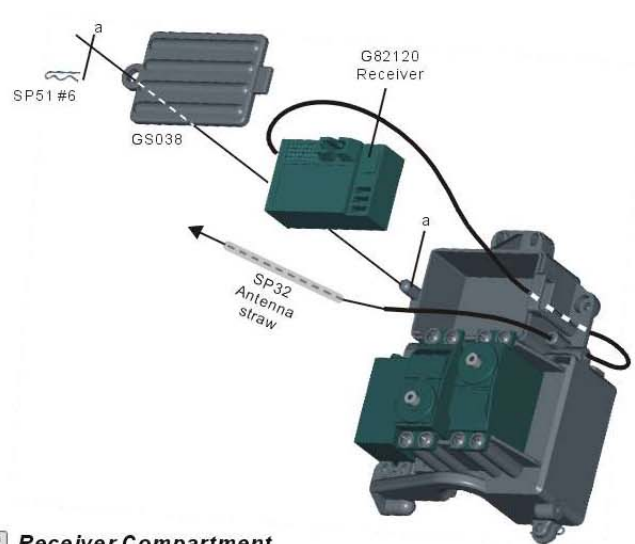

72 Receiver Compartment

1. Feed the antenna wire through the outlet hole located on the inside of the receiver compartment.
2. Mount and secure the GS038 compartment cover with one SP51 clip.
3. Gently slide the antenna wire up through the SP32 antenna straw and press into mount.

Engine

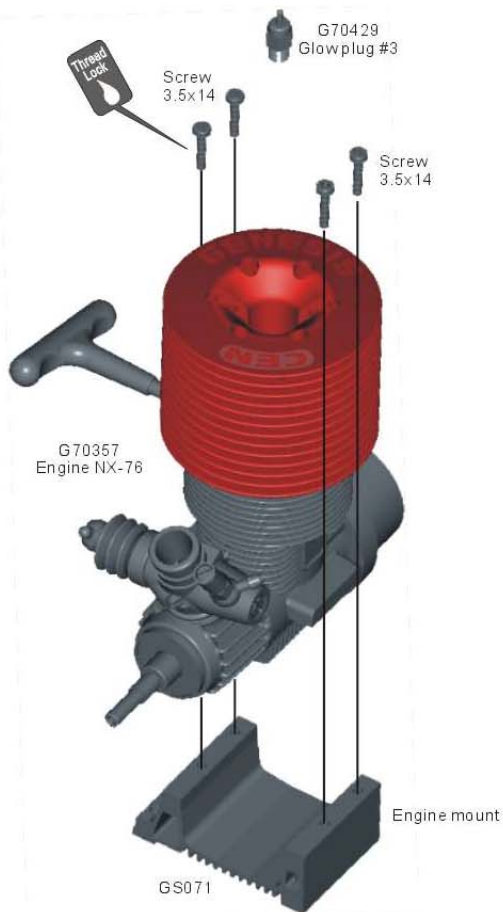

73 Engine Mount

1. Mount the engine to the engine mount using four 3.5x14 cap head screws.
- Notice:* Thread lock recommended on these screws.

74 Vented Flywheel

1. Install one 9.6x14x0.5 copper shim onto the crankshaft followed by the drive cone (if needed).
2. Next slide the GS008 flywheel onto the drive cone and secure with the GS008 nut.

Notice: Thread lock is recommended for the nut.

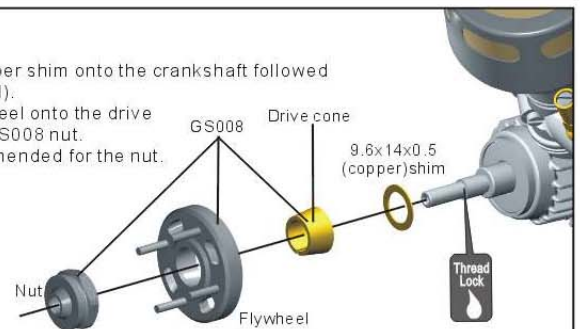

Note Direction

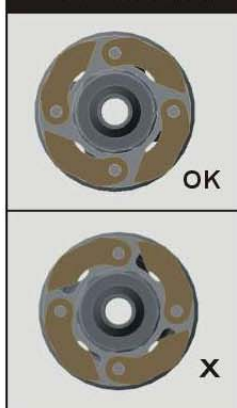

75 Clutch Shoes

1. Put one clutch spring into the center of each shoe lining up the eyelet with the hole in each shoe.
2. Press the shoe with the spring in the center half way onto the pin on the flywheel.
3. Using a flat head screwdriver press the small tab on the spring into the groove found on the clutch nut.
4. Press shoe and spring all the way down onto the flywheel pin.
5. Repeat for each shoe.
6. If done correctly the shoes will be held close by the springs.

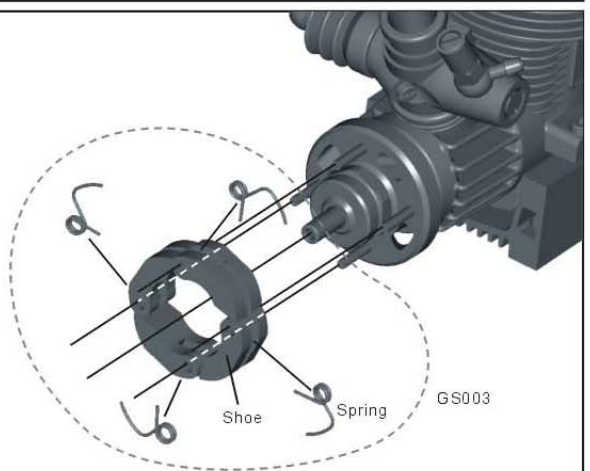

Front / Rear End

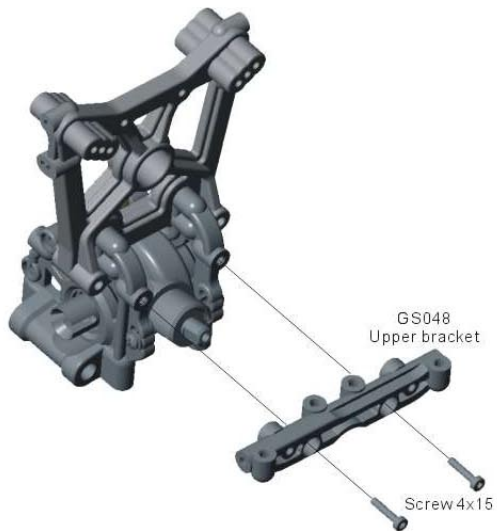

49 Upper Bracket x2

1. Secure the GS048 bracket to the rear bulkhead using two 4x15 screws.
2. Repeat for the front.

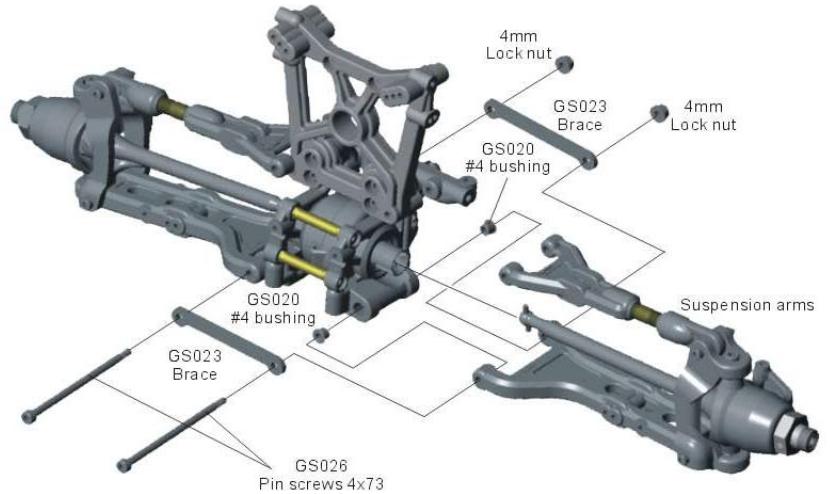

50 Front and Rear End

1. Attach the suspension arms using two GS026 pin screws, two aluminum braces, followed up with lock nuts.
2. Repeat for the front.

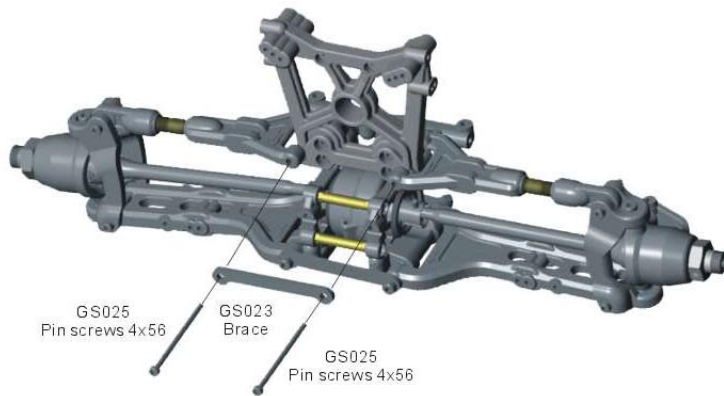

51 Front and Rear End

1. Now install the upper suspension arms and braces using GS025 pin screws, and GS023 aluminum brace.
2. Repeat for the front.

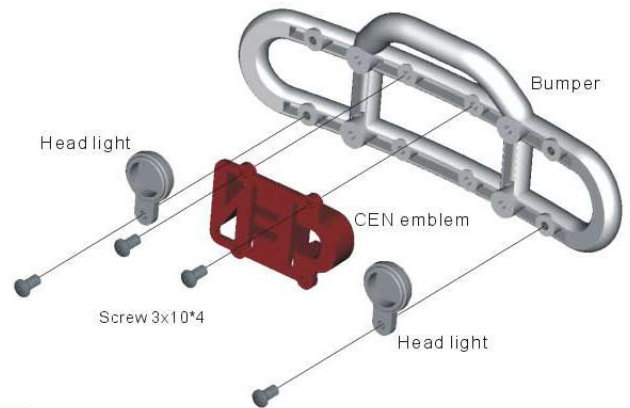

52 Front Bumper (GS042)

1. Attach the CEN emblem and head lights using 3x10 button head screws to the front bumper only.

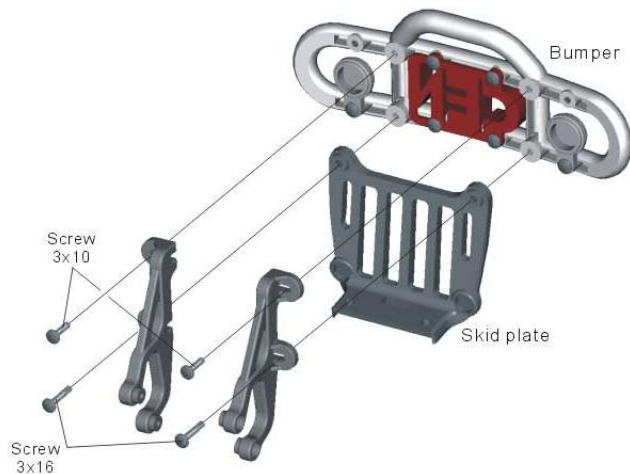

53 Front Bumper (GS042)

1. Attach bumper and skid plate using two 3x10 and two 3x16 button head screws. Notice 3x16 screws must go through skid plate into the bumper.

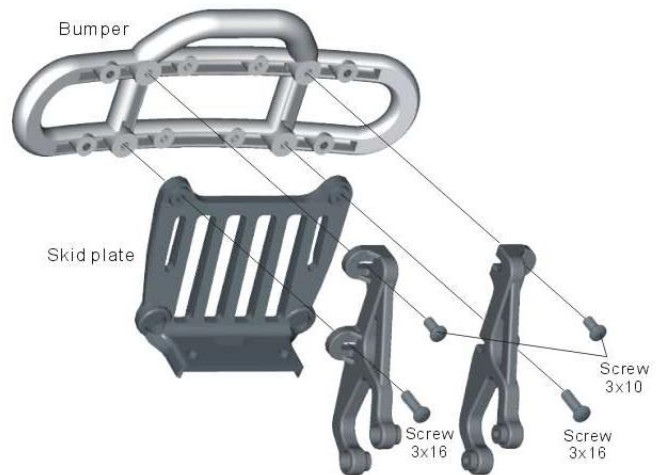

54 Rear Bumper (GS042)

1. Attach the bumper and skid plate using two 3x10 and two 3x16 button head screws. Notice 3x16 screws must go through skid plate into the bumper.